

02/06/2006



ALLEGATO 28

Comune di Pisa
 Tav. 16
Piano Attuativo
 "Oratoio, via Maggiore"
 proprietà: Fondiaria Paradisa S.r.l.
 Recupero Edilizio su impianto preurbano morfologicamente alterato
 Comune di Pisa
 Parco Urbano
 verifica di viabilità e adattabilità
 L.13/1989
 piano secondo, planimetria generale
 scala 1:50, 1:100, 1:200

MAURIZIO ANDRUETTO ARCHITETTO
 MONICA DERI ARCHITETTA
 FONDIARIA PARADISA S.r.l.
 maurizio andruetto monica deri
 architetti

56121 pisa, via emilia n° 95 tel. 050. 984418 fax 050. 3161422 E.mail momapsia @ libero.it

ELABORATO ADOTTATO
 CON DELIBERAZIONE
 Giunta Comunale
 Consiglio Comunale
 n° 4 del 01 FEB. 2007

SCHEMA DEGLI SPAZI ANTISTANTI E RETROSTANTI LA PORTA

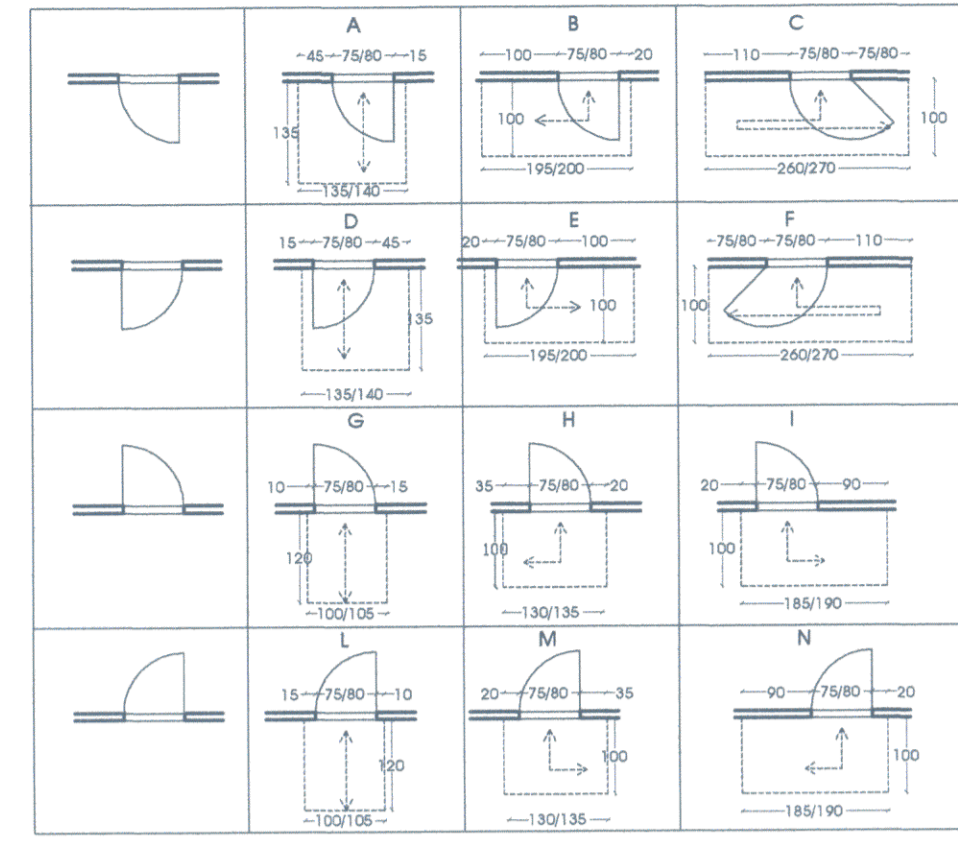

PERCORSO VISIBILITA'

SCHEMA ADATTABILITA' BAGNI

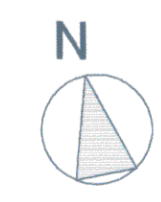
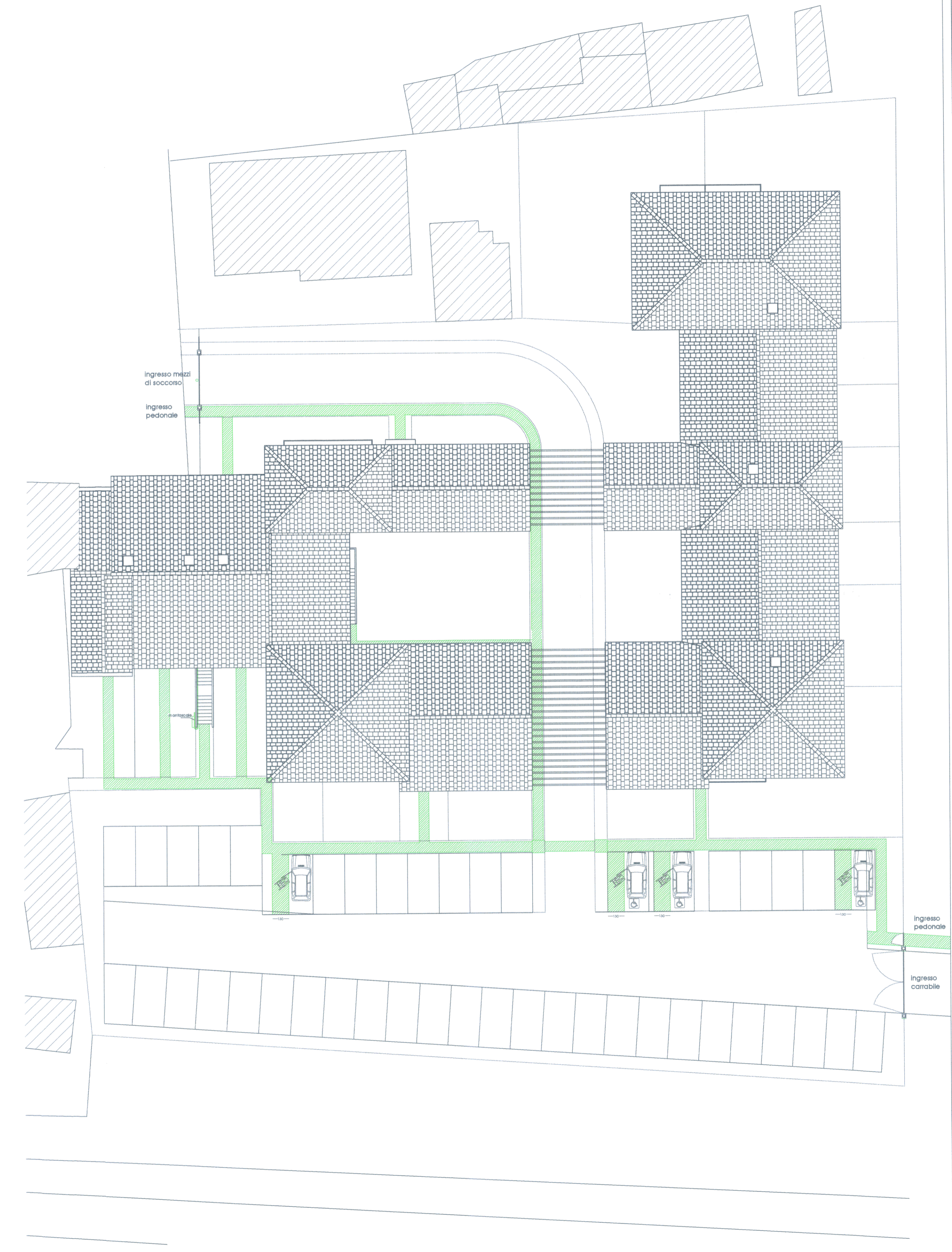
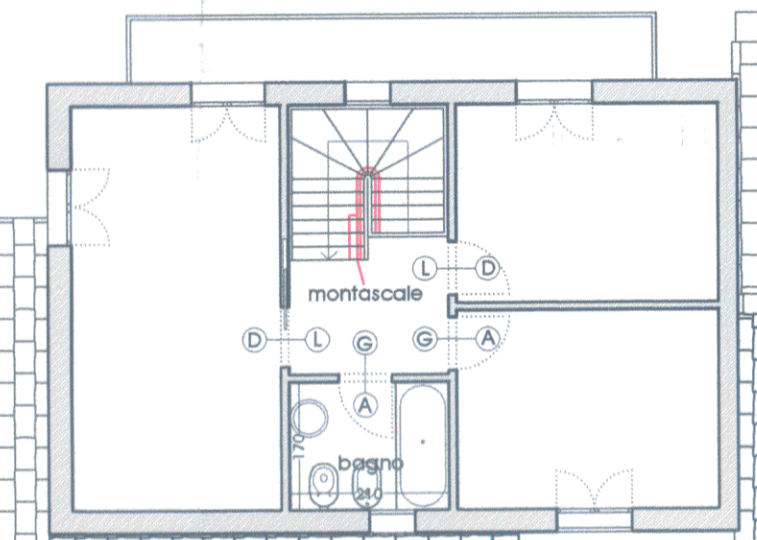
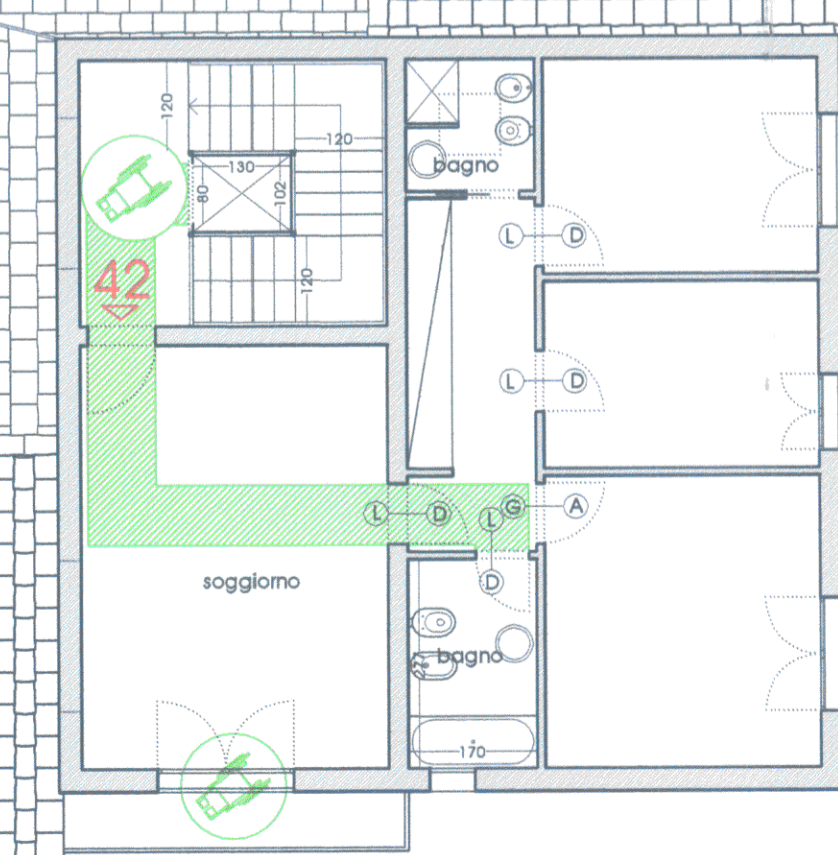
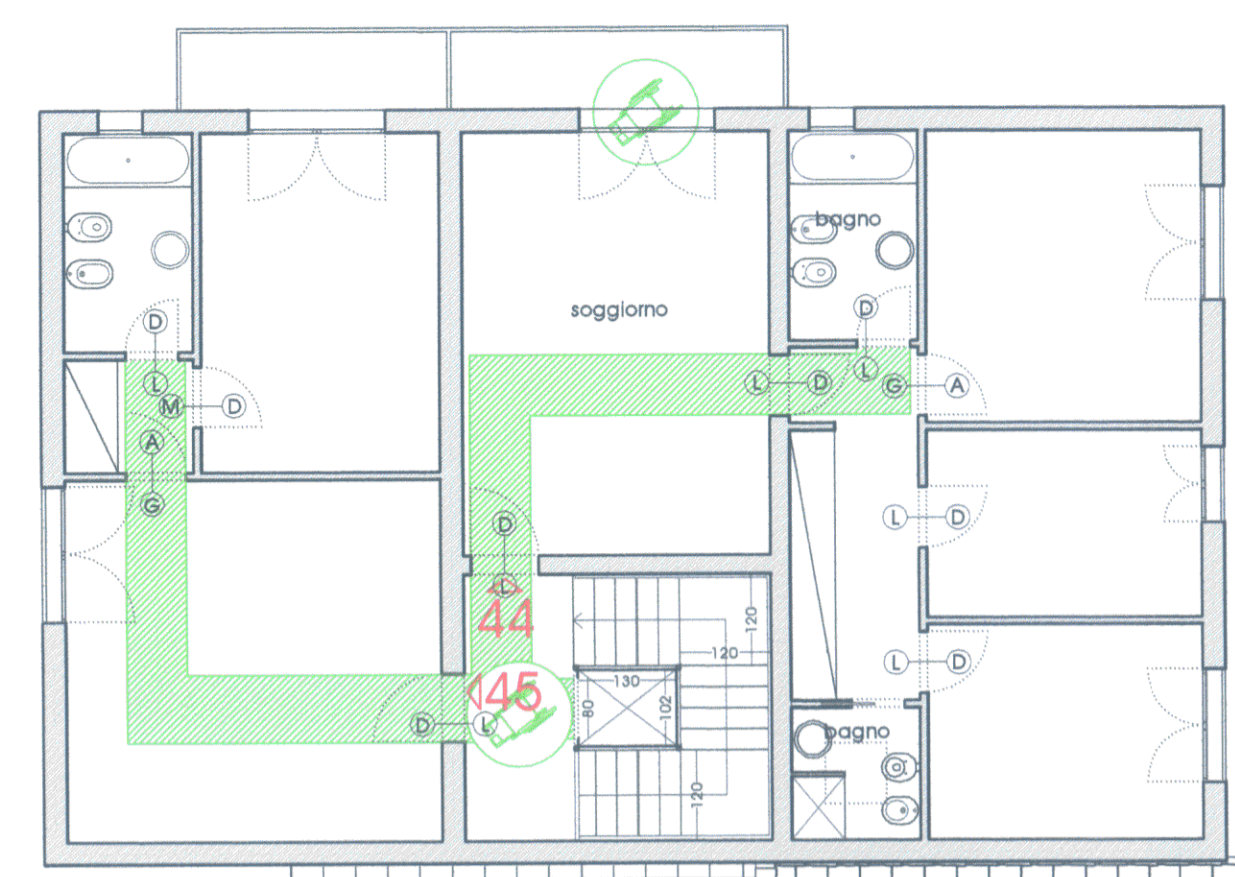
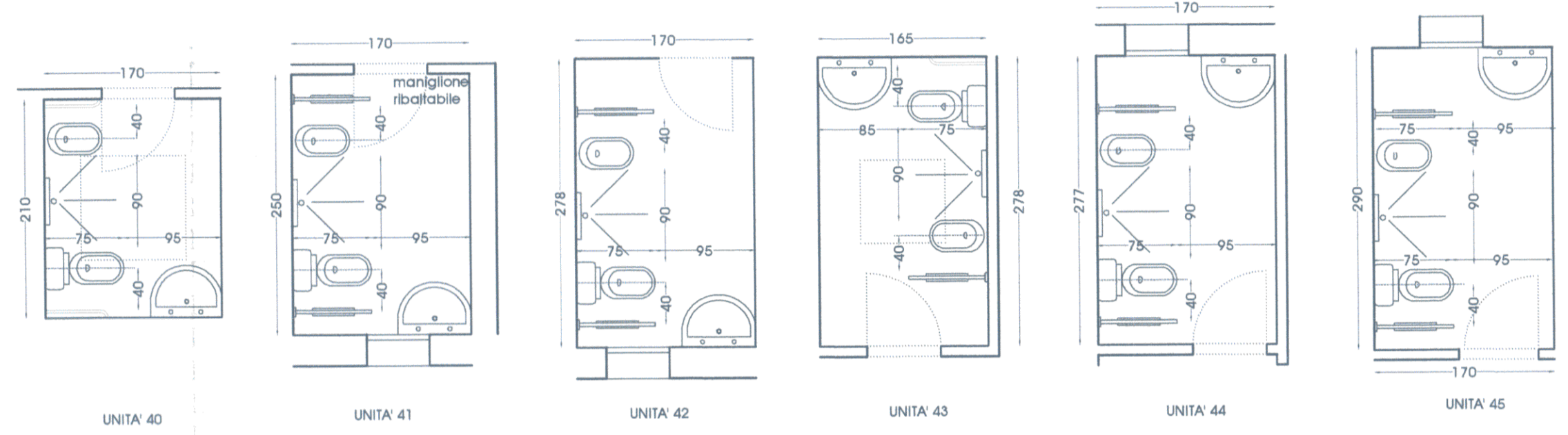

collaboratori: Daria Conte, Stefania Del Zoppo