

LEGENDA SIMBOLOGIA

- Confini territoriali comunali
- Infrastruttura esistente Retelit
- Pozzetto di nuova posa Open Fiber

Progettazione e Realizzazione della rete
MAN, dei collegamenti di Backhauling, di
Backbone e P2P

| | |
|---|--|
| <p>COMITENTE</p> <p>REGIONAL MANAGER TOSCANA CLAUDIO CARDARELLI</p> | <p>PROGETTISTA</p> <p>we connect your future</p> |
|---|--|



ISTANZA DI AUTORIZZAZIONE
RICHIESTA RIUTILIZZO INFRASTRUTTURE E
POSA POZZETTI DI ISPEZIONE

| | |
|---------------------|----------------|
| ELABORATO | COMUNE DI PISA |
| COROGRAFIA GENERALE | |

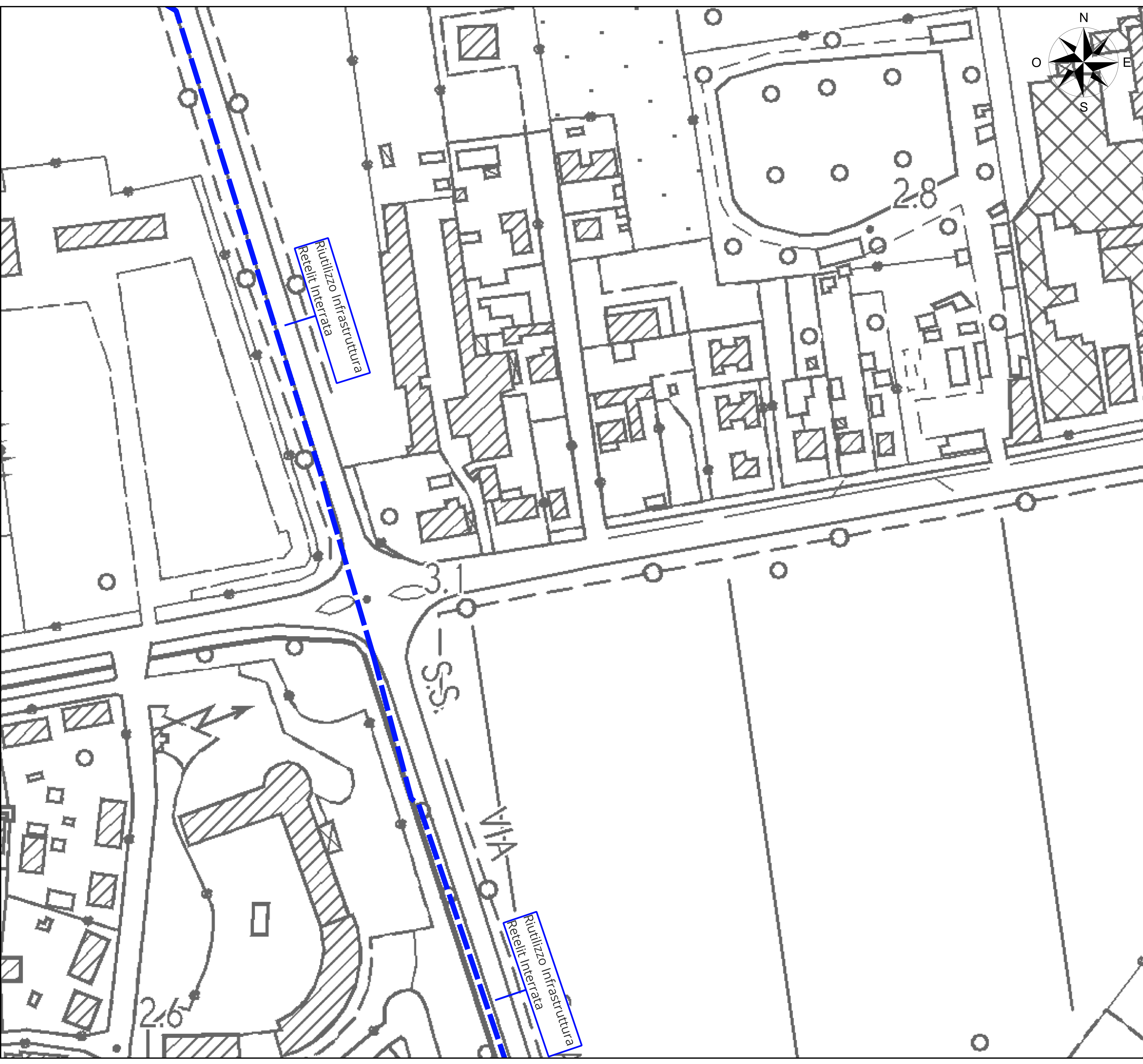
| REVISIONE | DATA | SCALA | NOME FILE | TAVOLA |
|-----------|----------|--------|------------|------------|
| 1.0 | 27.05.24 | 1:5000 | PISA PL 10 | COROGRAFIA |



LEGENDA SIMBOLOGIA

-  Confini territoriali comunali
-  Infrastruttura esistente Retelit
-  Pozzetto di nuova posa Open Fiber

Progettazione e Realizzazione della rete
MAN, dei collegamenti di Backhauling, di
Backbone e P2P

COMMITTENTE



REGIONAL MANAGER TOSCANA
CLAUDIO CARDARELLI

PROGETTISTA



we connect your future

ISTANZA DI AUTORIZZAZIONE
RICHIESTA RIUTILIZZO INFRASTRUTTURE E
POSA POZZETTI DI ISPEZIONE

ELABORATO



COROGRAFIA GENERALE

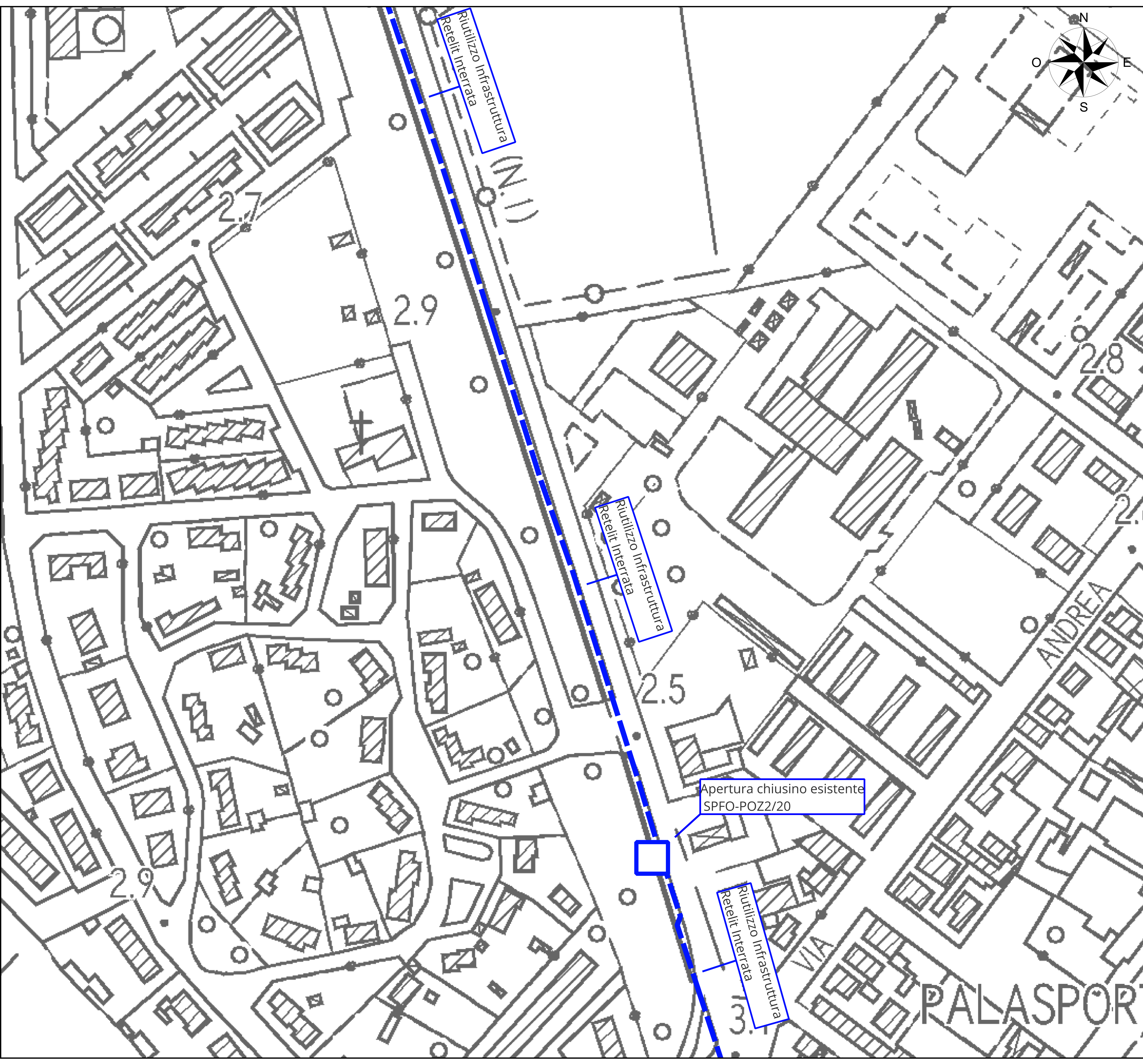

COMUNE DI PISA

| REVISIONE | DATA | SCALA | NOME FILE | TAVOLA |
|-----------|----------|-------|------------|--------|
| 1.0 | 27.05.24 | 1:500 | PISA PL 10 | 1 |

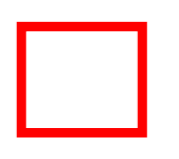

LEGENDA SIMBOLOGIA

| | |
|---|-----------------------------------|
|  | Confini territoriali comunali |
|  | Infrastruttura esistente Retelit |
|  | Pozzetto di nuova posa Open Fiber |

| | | | | |
|--|----------|--|------------|--------|
| Progettazione e Realizzazione della rete MAN, dei collegamenti di Backhauling, di Backbone e P2P | | | | |
| COMMITTENTE  REGIONAL MANAGER TOSCANA CLAUDIO CARDARELLI | | PROGETTISTA  we connect your future | | |
| ISTANZA DI AUTORIZZAZIONE RICHIESTA RIUTILIZZO INFRASTRUTTURE E POSA POZZETTI DI ISPEZIONE | | | | |
| ELABORATO COROGRAFIA GENERALE | | COMUNE DI PISA | | |
| REVISIONE | DATA | SCALA | NOME FILE | TAVOLA |
| 1.0 | 27.05.24 | 1:500 | PISA PL 10 | 2 |

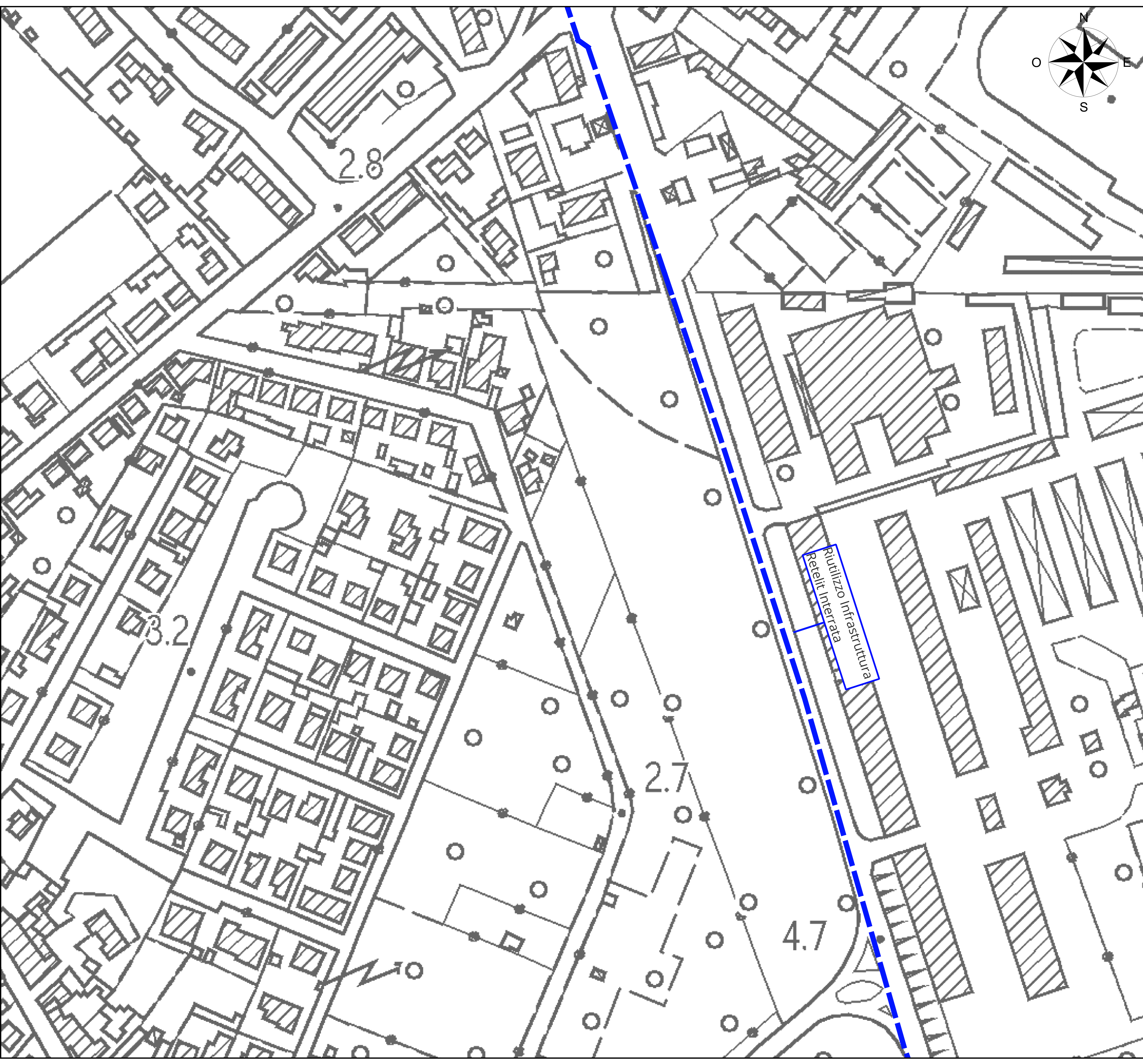

LEGENDA SIMBOLOGIA

- Confini territoriali comunali
- Infrastruttura esistente Retelit
- Pozzetto di nuova posa Open Fiber

Progettazione e Realizzazione della rete
MAN, dei collegamenti di Backhauling, di
Backbone e P2P

| | |
|--|---|
| <p>COMMITTENTE</p> <p>open fiber</p> <p>REGIONAL MANAGER TOSCANA CLAUDIO CARDARELLI</p> | <p>PROGETTISTA</p> <p>telebit we connect your future</p> |
|--|---|



ISTANZA DI AUTORIZZAZIONE
RICHIESTA RIUTILIZZO INFRASTRUTTURE E
POSA POZZETTI DI ISPEZIONE

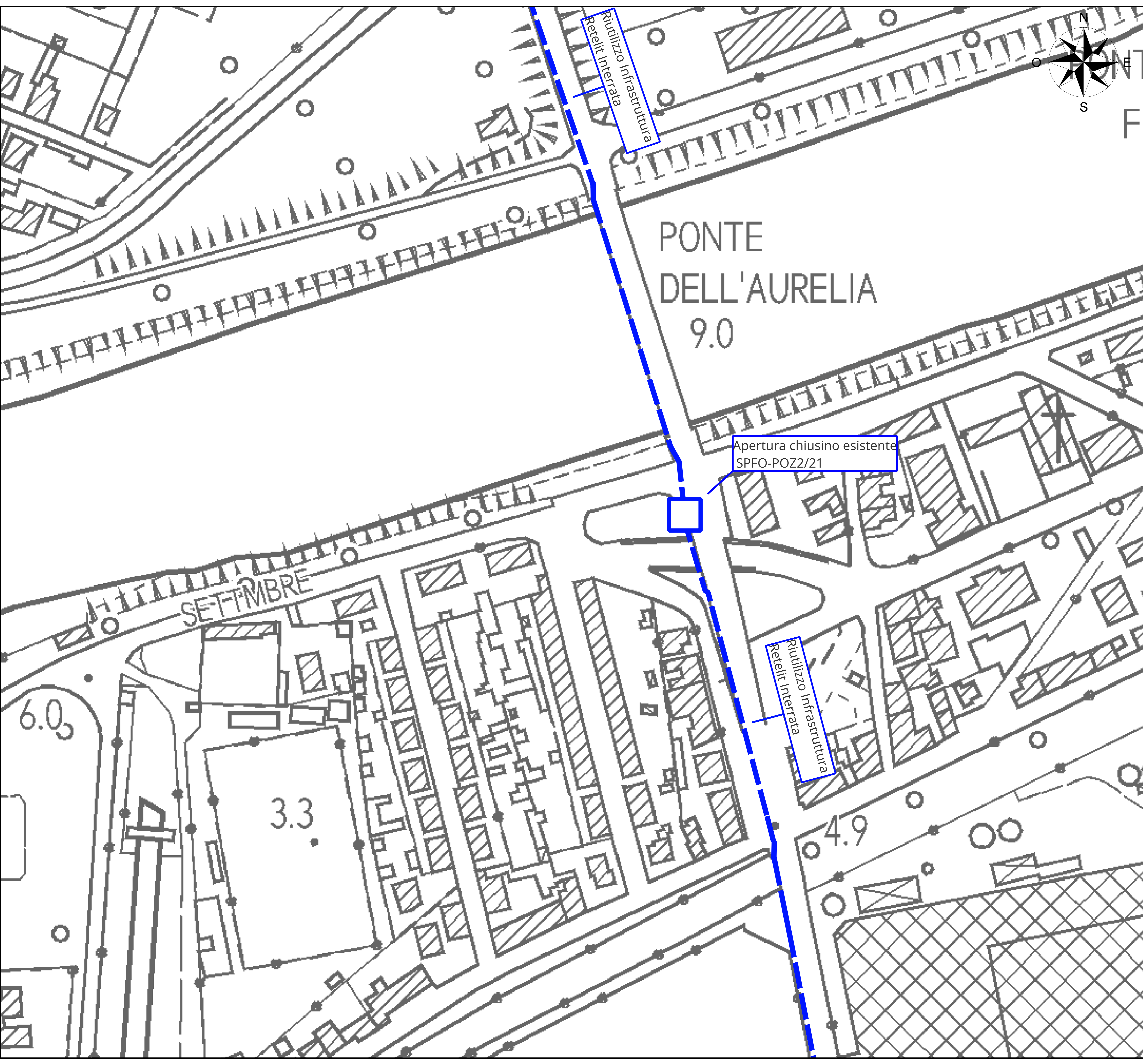

| | | | | |
|---------------------|--|----------------|--|--|
| ELABORATO | | COMUNE DI PISA | | |
| COROGRAFIA GENERALE | | | | |

| REVISIONE | DATA | SCALA | NOME FILE | TAVOLA |
|-----------|----------|-------|------------|--------|
| 1.0 | 27.05.24 | 1:500 | PISA PL 10 | 3 |

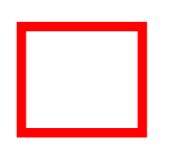

LEGENDA SIMBOLOGIA

| | |
|---|-----------------------------------|
|  | Confini territoriali comunali |
|  | Infrastruttura esistente Retelit |
|  | Pozzetto di nuova posa Open Fiber |

| | | | | |
|--|----------|--|------------|--------|
| Progettazione e Realizzazione della rete MAN, dei collegamenti di Backhauling, di Backbone e P2P | | | | |
| COMMITTENTE  REGIONAL MANAGER TOSCANA CLAUDIO CARDARELLI | | PROGETTISTA  we connect your future | | |
| ISTANZA DI AUTORIZZAZIONE RICHIESTA RIUTILIZZO INFRASTRUTTURE E POSA POZZETTI DI ISPEZIONE | | | | |
| ELABORATO COROGRAFIA GENERALE | | COMUNE DI PISA | | |
| REVISIONE | DATA | SCALA | NOME FILE | TAVOLA |
| 1.0 | 27.05.24 | 1:500 | PISA PL 10 | 4 |



Apertura chiusino esistente

Riutilizzo Infrastruttura Retelit Interrata

Riutilizzo Infrastruttura Retelit Interrata



3.0

3.7

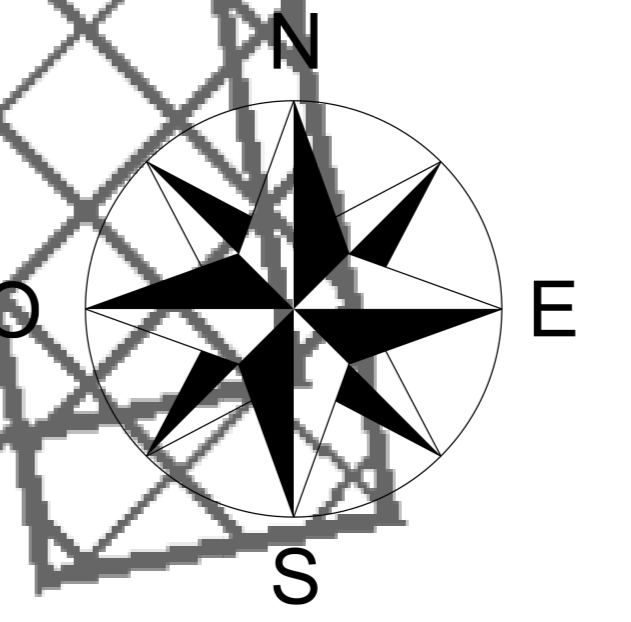
2.9



LEGENDA SIMBOLOGIA

-  Confini territoriali comunali
-  Infrastruttura esistente Retelit
-  Pozzetto di nuova posa Open Fiber

Progettazione e Realizzazione della rete MAN, dei collegamenti di Backhauling, di Backbone e P2P

COMMITTENTE



REGIONAL MANAGER TOSCANA
CLAUDIO CARDARELLI

PROGETTISTA



we connect your future

ISTANZA DI AUTORIZZAZIONE
RICHIESTA RIUTILIZZO INFRASTRUTTURE E
POSA POZZETTI DI ISPEZIONE

ELABORATO

COROGRAFIA GENERALE

COMUNE DI PISA

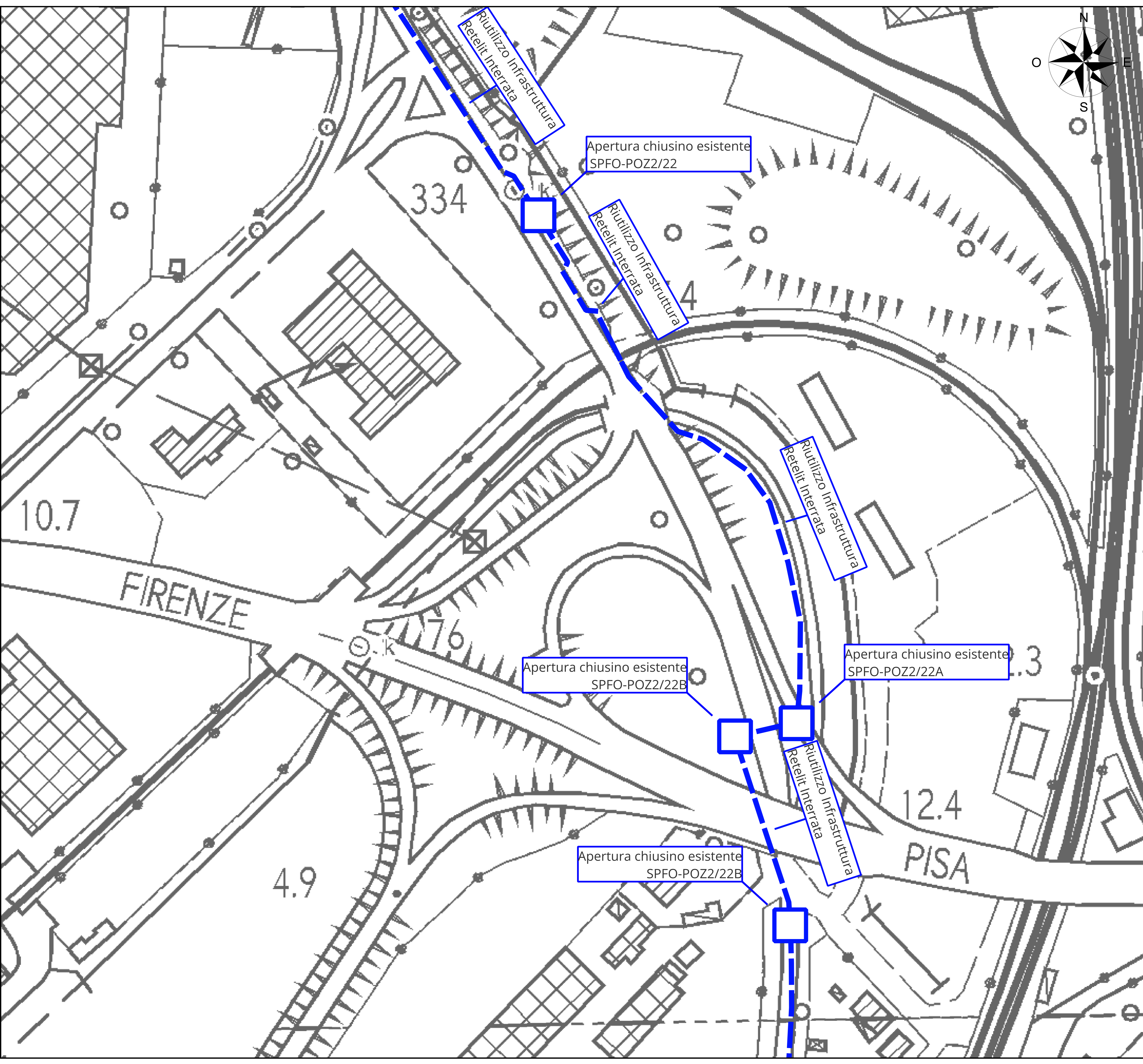

| REVISIONE | DATA | SCALA | NOME FILE | TAVOLA |
|-----------|----------|-------|------------|--------|
| 1.0 | 27.05.24 | 1:500 | PISA PL 10 | 5 |



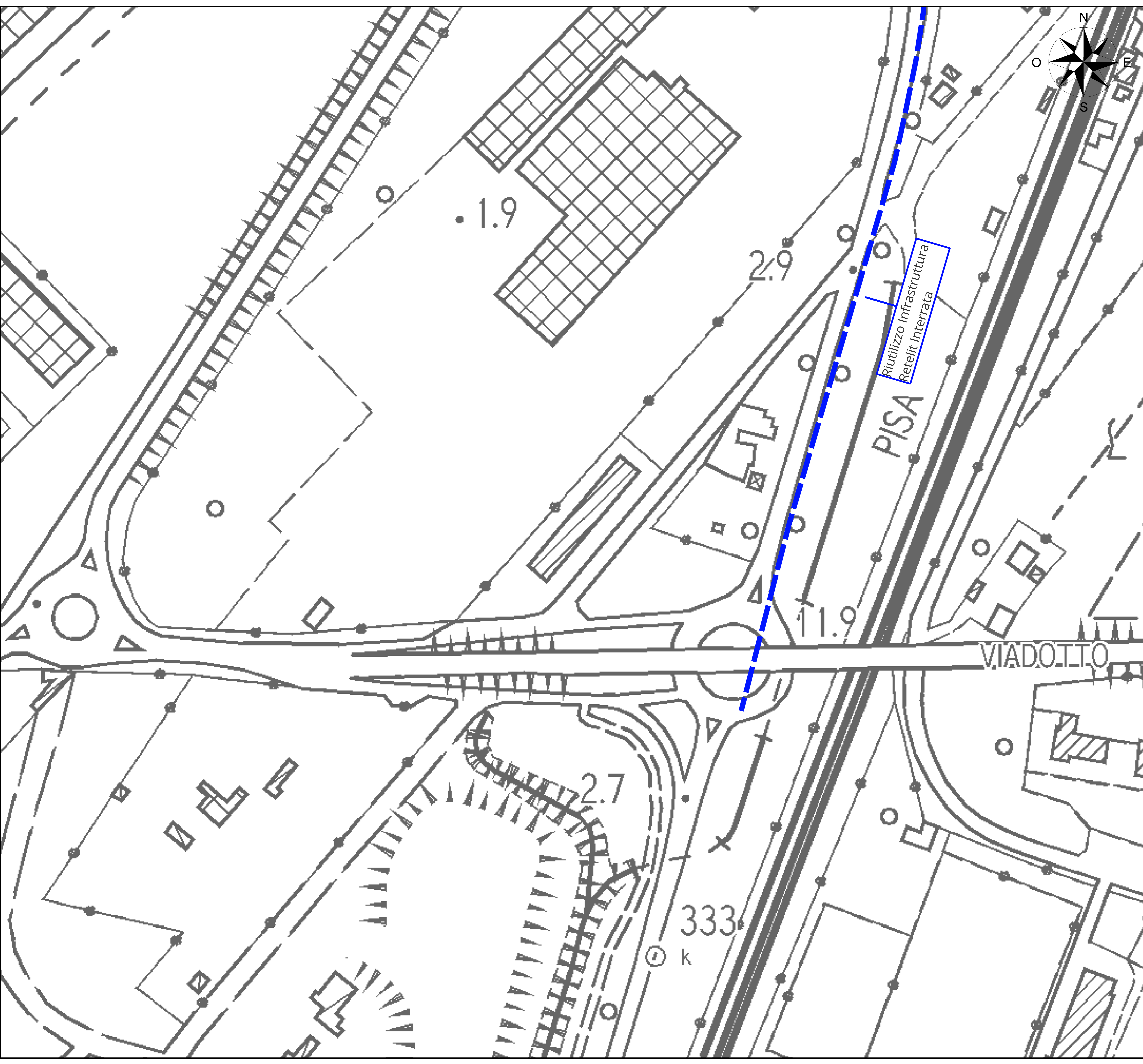

| LEGENDA SIMBOLOGIA | |
|--------------------|-----------------------------------|
| | Confini territoriali comunali |
| | Infrastruttura esistente Retelit |
| | Pozzetto di nuova posa Open Fiber |

| | | | | |
|--|----------|---|------------|--------|
| Progettazione e Realizzazione della rete MAN, dei collegamenti di Backhauling, di Backbone e P2P | | | | |
| COMMITTENTE REGIONAL MANAGER TOSCANA CLAUDIO CARDARELLI | | PROGETTISTA we connect your future | | |
| ISTANZA DI AUTORIZZAZIONE RICHIESTA RIUTILIZZO INFRASTRUTTURE E POSA POZZETTI DI ISPEZIONE | | | | |
| ELABORATO | | COMUNE DI PISA | | |
| COROGRAFIA GENERALE | | | | |
| REVISIONE | DATA | SCALA | NOME FILE | TAVOLA |
| 1.0 | 27.05.24 | 1:500 | PISA PL 10 | 6 |

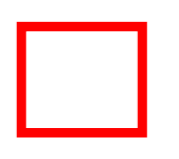

| LEGENDA SIMBOLOGIA | |
|---|-----------------------------------|
|  | Confini territoriali comunali |
|  | Infrastruttura esistente Retelit |
|  | Pozzetto di nuova posa Open Fiber |

| | | | | |
|--|----------|--|----------------|--------|
| Progettazione e Realizzazione della rete MAN, dei collegamenti di Backhauling, di Backbone e P2P | | | | |
| COMMITTENTE  REGIONAL MANAGER TOSCANA CLAUDIO CARDARELLI | | PROGETTISTA  we connect your future | | |
| ISTANZA DI AUTORIZZAZIONE RICHIESTA RIUTILIZZO INFRASTRUTTURE E POSA POZZETTI DI ISPEZIONE | | | | |
| ELABORATO | | | COMUNE DI PISA | |
| COROGRAFIA GENERALE | | | | |
| REVISIONE | DATA | SCALA | NOME FILE | TAVOLA |
| 1.0 | 27.05.24 | 1:500 | PISA PL 10 | 7 |

PARTICOLARI COSTRUTTIVI

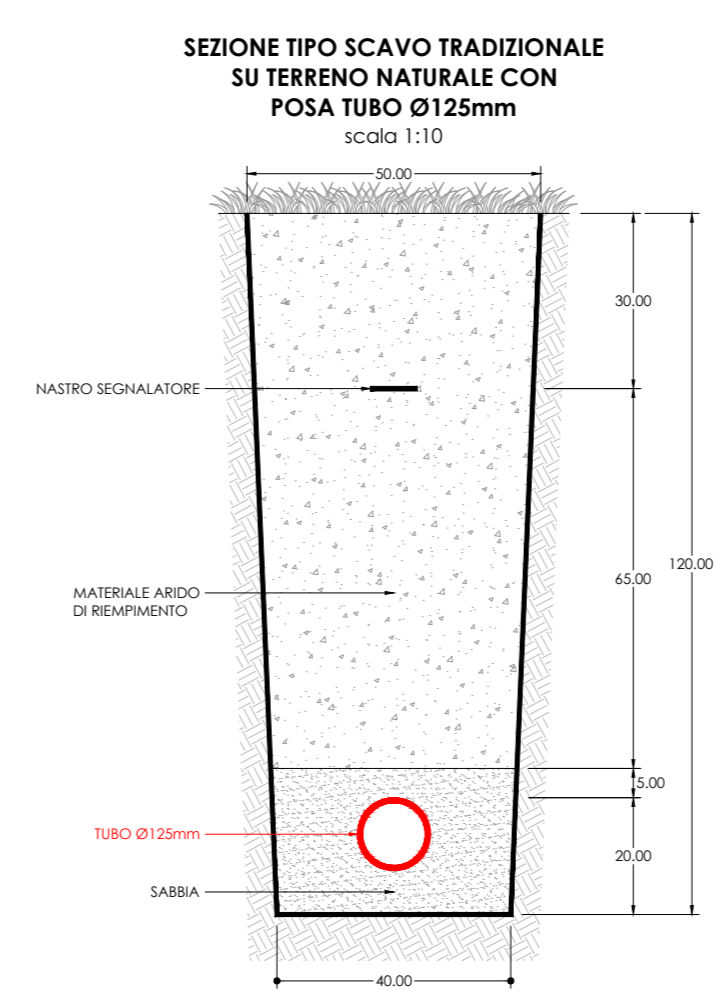
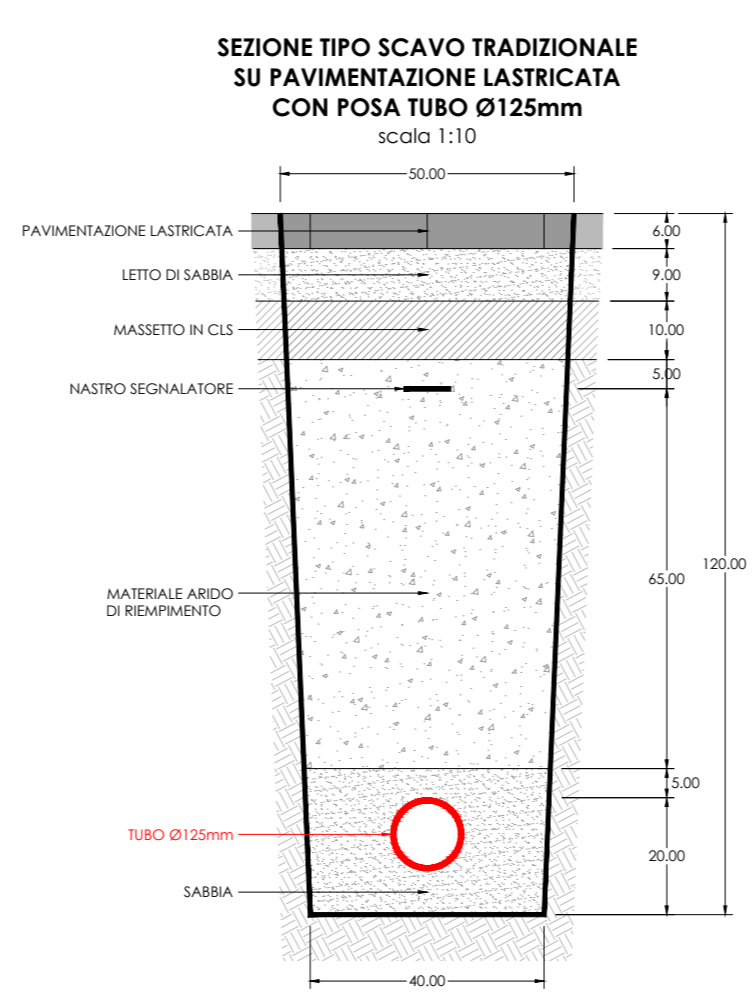
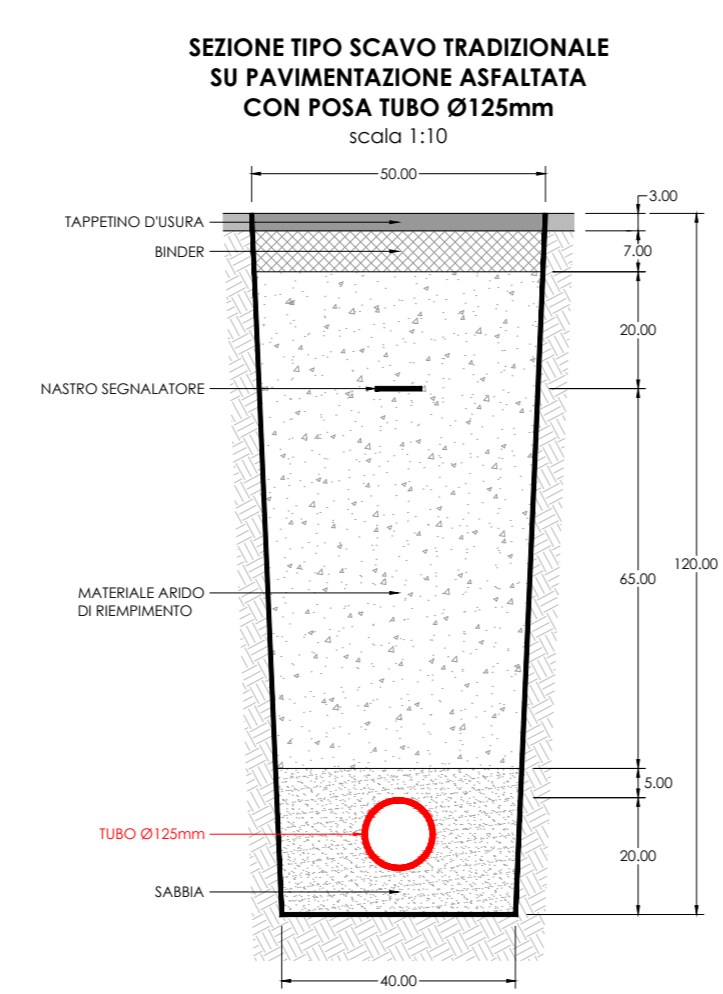
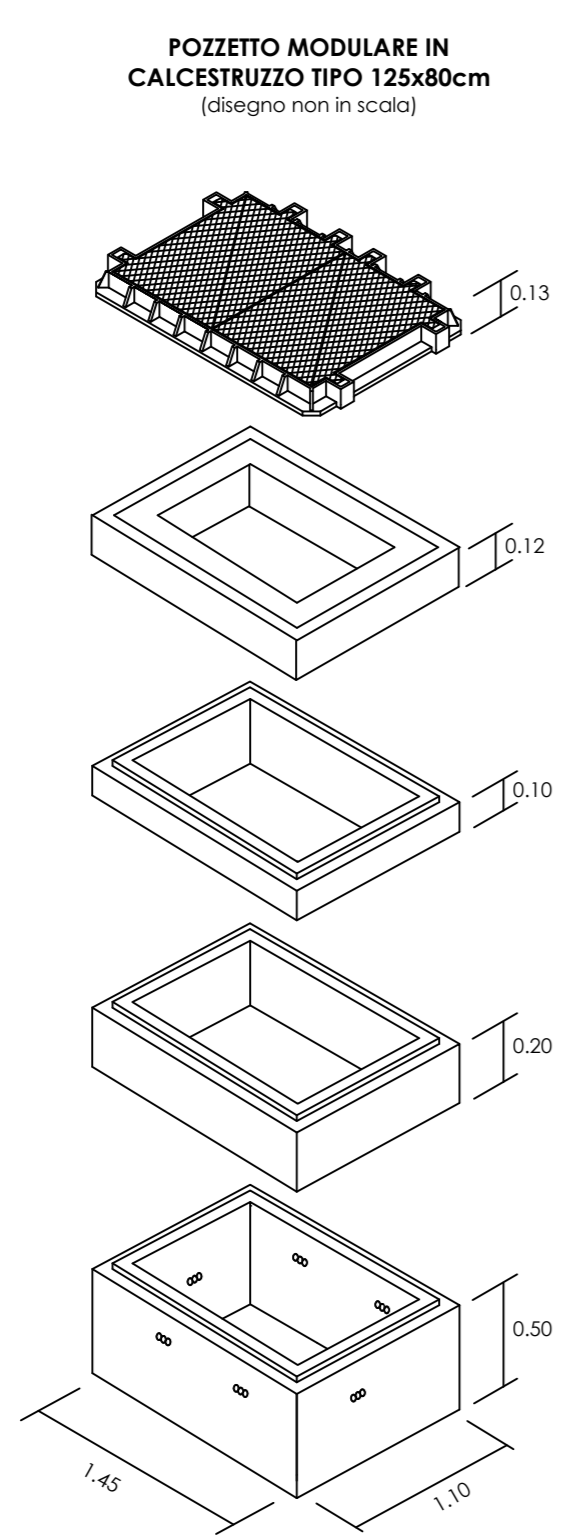
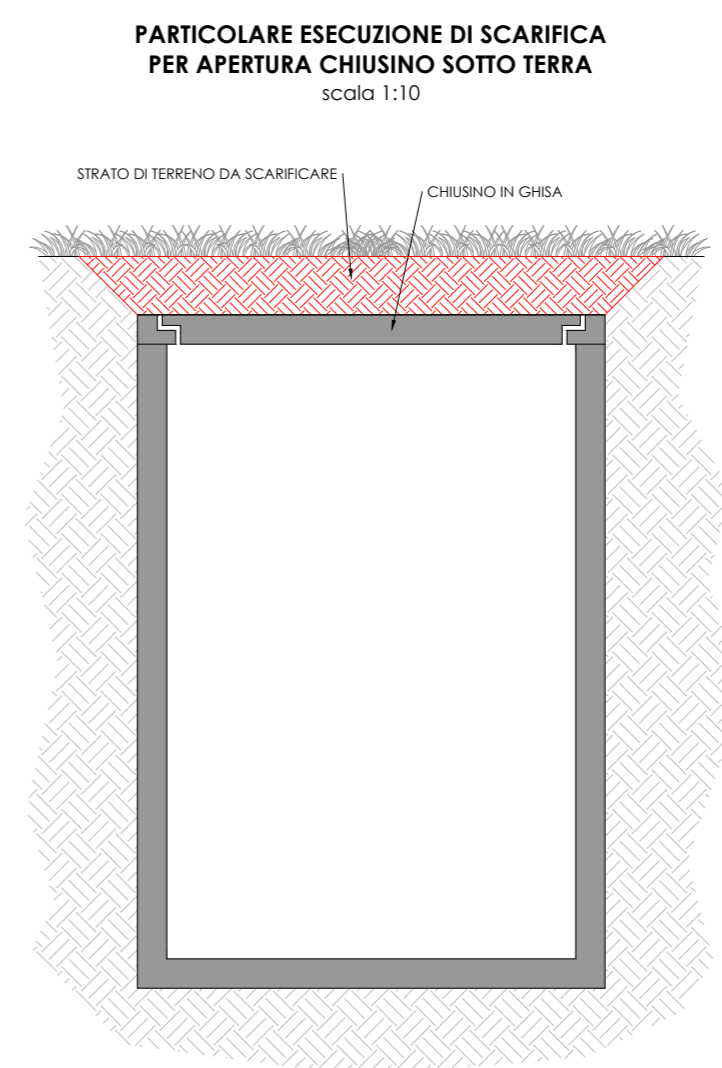
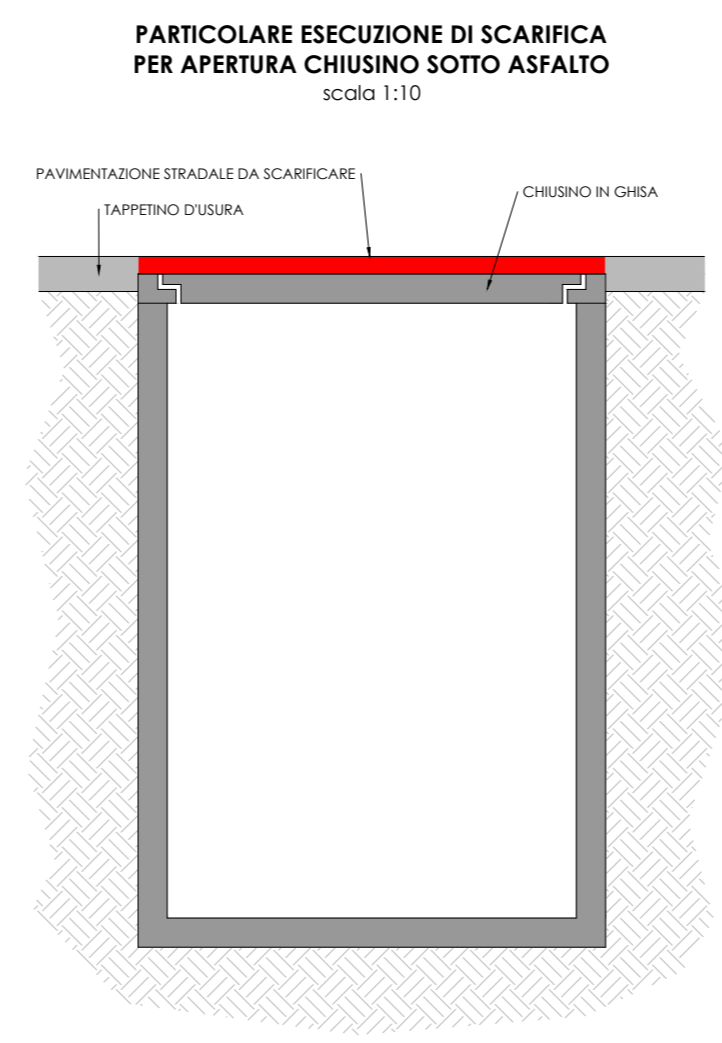

Progettazione e Realizzazione della rete MAN, dei collegamenti di Backhauling, di Backbone e P2P



ISTANZA DI AUTORIZZAZIONE

ELABORATO

PARTICOLARI COSTRUTTIVI

| REVISIONE | DATA | AGGIORNAMENTI | SCALA | TAVOLA |
|-----------|------|---------------|-------|--------|
| 1.0 | | | | P.C. |
| | | | | |
| | | | | |