

## SWITCH Deliverable Summary Sheet

<b>SWITCH Document</b> (SWITCH Transition Manual)
<b>Deliverable reference: D1.3.4</b>
<b>Author(s) and Institution(s)</b> Chris Jefferies and Alison Duffy, University of Abertay
<b>Publication date</b> Final version 11 <sup>th</sup> April 2011
<b>Audience</b> The SWITCH Transition Manual is intended for national and local decision makers such as city mayors and members of parliament. It will also be of great assistance to urban water practitioners and decision makers in the urban water sector including local government, urban planners and water utilities.
<b>Purpose</b>  The SWITCH Transition Manual is a final output of the SWITCH project. Its purpose is to provide a coherent methodology to enable a city to change its water system from today's state into a better condition in the future. The manual is a guide to implementing the SWITCH Transition Framework.
<b>Background</b> Transitions are usually long term processes that occur due to the co-evolution of several societal, economic (market-driven) and technological processes. The manual is a guide to the underlying driving forces and mechanisms behind the processes and actions that may influence a change.  The manual is intended to address some of the scepticism and misconceptions around the idea of transitioning. The possibilities of influencing long-term changes, who are the key players and identifying what is to be changed are all addressed. The manual also shows how to define appropriate starting points, how the change can be achieved and whether it is going in the right direction. These issues are not easily addressed, but it is hoped that this manual helps clarify who, where, what, when and how.  The 'socio-technical systems' or 'complex systems' that we want to transition are the urban water systems that provide our cities with water supply, sanitation and drainage services. Good quality, safe and clean water supplies, and attractive watercourses, which do not cause problems with flooding, are goals for any city of the future. To achieve this, the function and interaction of urban water cycles, water supply, drainage and river systems, and how they interact with society, must be understood. It is not the scope of this manual to go into the finer details of the urban water cycle or integrated urban water management since operational details of methods and tools are widely available. This manual has been written to show the direction needed to take forward the transitioning of water systems in a city.

**Potential Impact**

Directions are given for implementing strategic niche management processes for rolling out innovations in cities through the application of the SWITCH tools for transitioning, many of which are SWITCH project outputs but including others that are relevant to transitioning. It is important that innovations are nurtured for the delivery of sustainable urban water systems since they provide the scope and pathways for a transition to occur. Many city demonstration projects are illustrated showing the niches where the innovations are located. Innovations do not occur by themselves, and many types of socio-technical transitions result from transition management and the creation of environments for innovative niches to grow. The niches considered in this manual focus on three key knowledge areas: technical, financial, and, governance/ institutions. These niches provide useful examples for transferring this knowledge to decision makers, managers and practitioners.

Transitioning is illustrated through Case Study ‘stories’ from four of the **SWITCH** cities - Accra in Ghana, Alexandria in Egypt, Łódź in Poland and Belo Horizonte in Brazil. The case studies show how a SWITCH transition is occurring, and might occur in the future. A city that will be facing change in the future should find these stories useful. An analysis of past water developments and the intervention in SWITCH was undertaken to see how the transition occurred or might occur in future. Barriers that blocked a transitioning trajectory are examined to identify the issues so that lessons can be learned and clearer ideas of what will work better can be formulated for the next transitioning round. Each city story includes a timeline for the years 2010 – 2033 based on this analysis to show how changes may occur in future.

**Recommendations** Use the SWITCH approach to change your city. Transitioning works and this manual shows clearly how it might be done.

# The SWITCH Transition Manual

## Managing Water for the City of the Future

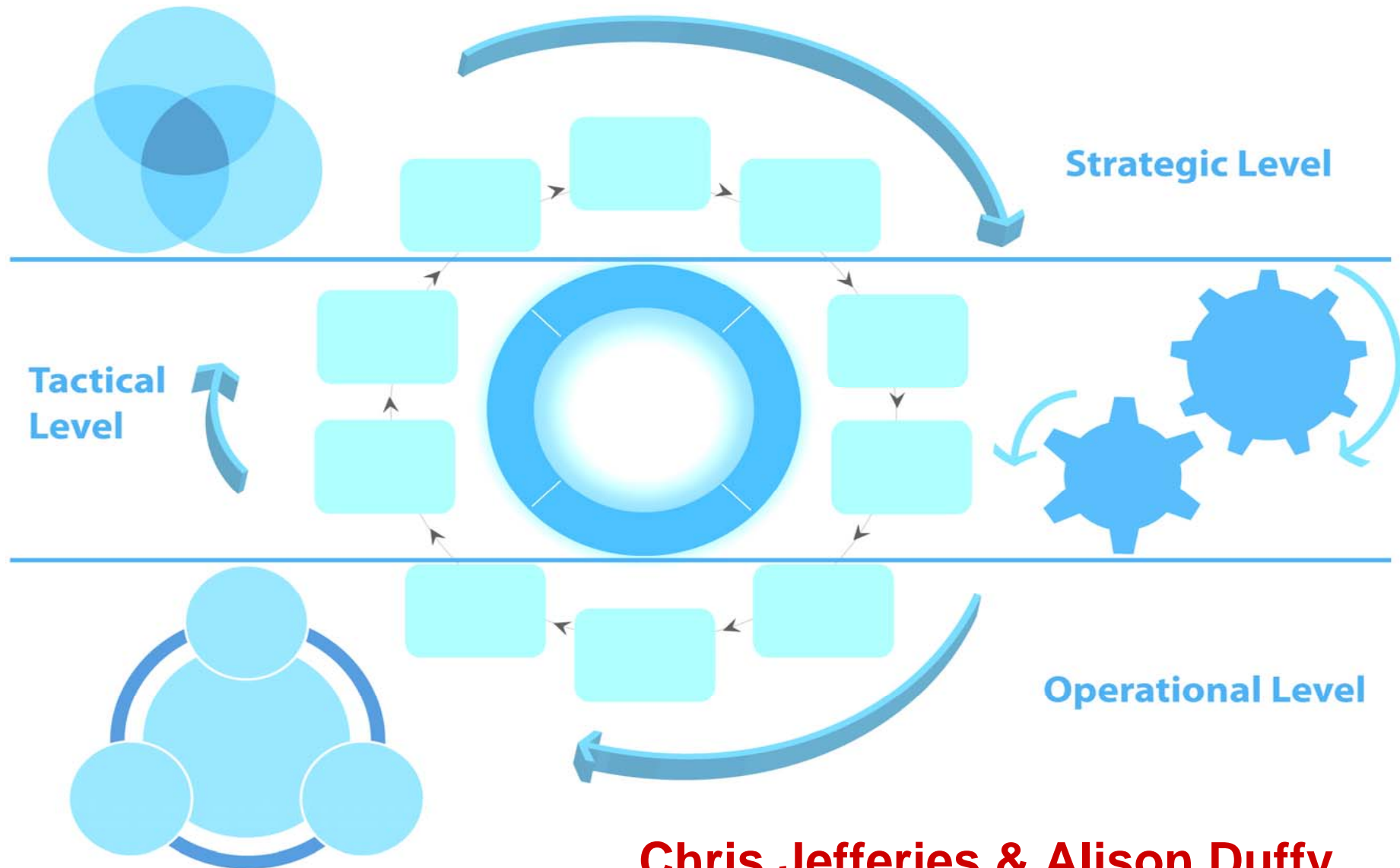

**Chris Jefferies & Alison Duffy**



# The SWITCH Transition Manual

**Authors: Chris Jefferies and Alison Duffy**  
**University of Abertay Dundee, United Kingdom**  
[c.jefferies@abertay.ac.uk](mailto:c.jefferies@abertay.ac.uk)

© University of Abertay Dundee

ISBN 1-899796-23-1 (10 digit) and 978-1-899796-23-6. (13 Digit)



The content in this (product) is under a license of Creative Commons specified as Attribution-Noncommercial-Share Alike 3.0. This license allows others to remix, tweak, and build upon the (product) materials for non-commercial purposes, as long as they credit the copyright holder and license their new creations under the identical terms. <http://creativecommons.org/licenses/by-nc-sa/3.0/>  
The full legal text concerning the terms of use of this license can be found at <http://creativecommons.org/licenses/by-nc-sa/3.0/legalcode>



[www.switchurbanwater.eu](http://www.switchurbanwater.eu)



## Table of Contents

### Section 1 Setting the Scene

<b>Introduction</b>	<b>3</b>
What's the problem – Why SWITCH from the old paradigm?	5
Examples of the problem	6
What can we do about it?	7
What is the new paradigm?	8
<b>What is transitioning?</b>	<b>10</b>
The Multi-Phase Concept	10
Multi-Level Perspective	12
Transition Management	14
<b>Transition Management Levels</b>	<b>15</b>
The Strategic Level	16
The Tactical Level	16
The Operational Level	17
What might a transition city look like?	18
Examples of moving towards the new paradigm	20

### Section 2 The SWITCH Transition Framework Explained

<b>The Transition Framework</b>	<b>25</b>
The Transition Management Cycle	25
Transition Management Clusters	26
The SWITCH Learning Alliances	27
Strategic Planning	27
Visioning	28
Strategic Niche Management	31
SWITCH Transitioning City Stories	32
Tools Used in Transitioning	32

### Section 3 The Transition Management Cycle

<b>Transition Clusters and Transition Management Activities</b>	<b>35</b>
Transition Management Clusters	35
The Arena	36
The Agenda	38
Experiments	39
Monitoring, Evaluating, Learning	40
<b>Transition Management Activities</b>	<b>41</b>
Develop the Transition Arena	42
Organise / Facilitate Stakeholders	43
Identify Problems and Issues	44
Develop Long Term Integrated Vision	44
Developing Transition Agenda	45
Transition Experiments	46
Identify Responsible Parties	47
Process Documentation & Capacity Building	47
Evaluation and Learning	48
Next Transition Round of Transitioning and Visioning	48

## **Section 4 Strategic Niche Management – The Demonstrations in the Cities**

### **Strategic Niche Management 50**

SWITCH Demonstrations	51
Scaling up	51
Water Quality Projects in Tel Aviv	52
Ma'awa Sayadeen (Fishing Village) in Alexandria	53
Demonstration Projects in Łódź	54
Demonstration Projects in Belo Horizonte	56
Demonstration Projects in Birmingham	58
The Applicability of Innovations in Global Cities	60

## **Section 5 Transitioning Stories - Four SWITCH Cities**

The SWITCH Case Study Cities	<b>64</b>
City Images	65
City Transition Strengths	66
Analysis of Water Service Delivery	68
1 Transitioning Urban Water in Accra	70
2 Transitioning Urban Water in Alexandria	78
3 Transitioning Urban Water in Łódź	84
4 Transitioning Urban Water in Belo Horizonte	90

## **Section 6 Example Tools for Transitioning**

### **Example Tools for Transitioning 98**

1 CWIS – City Water Information System	99
2 CWB – City Water Balance	103
3 CWE – City Water Economics	107
4 SUDS for Roads - A Decision Support Selection Tool	113
5 Infoworks – Removing surface water from sewers	117
6 WDM - Water Demand Management Options	121
7 SUDSLOC - A GIS based decision support tool	125
8 SASIW - Systematic Approach for Social Inclusion	129
9 The Economics of Rainwater Harvesting	133
10 Costing for Sustainable Options	139

## **Section 7 Further Information**

### **References 144**

### **Web Links 146**

## Executive Summary

**SWITCH** (Sustainable Water Improves Tomorrow's Cities Health) was a research programme funded under the EU FP6 programme. It was aimed at achieving more sustainable integrated urban water management in the 'City of the Future', 30-50 years hence. In order to address these challenges, **SWITCH** aimed to facilitate a paradigm shift in urban water management, changing from ad-hoc actions to a coherent and consolidated approach.

The **SWITCH** Transition Manual is a final output of the project. Its purpose is to provide a coherent methodology to enable a city to change its water system from today's state into a better condition in the future. The manual is a guide to implementing the **SWITCH** Transition Framework. It is intended for national and local decision makers such as city mayors and members of parliament. It will also be of great assistance to urban water practitioners and decision makers in the urban water sector including local government, urban planners and water utilities.

The manual guides all stakeholder groups at three different levels:

- **Strategic**, in which visions are set and strategic plans formulated;
- **Tactical**, enabling a wide variety of options to be evaluated by the stakeholders using the vehicle of the Learning Alliance, and;
- **Operational** short term activities including experimentation with innovative technologies.

Transitions are usually long term processes that occur due to the co-evolution of several societal, economic (market-driven) and technological processes. The manual is a guide to the underlying driving forces and mechanisms behind the processes and actions that may influence a change.

The manual is intended to address some of the scepticism and misconceptions around the idea of transitioning. The possibilities of influencing long-term changes, who are the key players and

identifying what is to be changed are all addressed. The manual also shows how to define appropriate starting points, how the change can be achieved and whether it is going in the right direction. These issues are not easily addressed, but it is hoped that this manual helps clarify who, where, what, when and how.

The 'socio-technical systems' or 'complex systems' that we want to transition are the urban water systems that provide our cities with water supply, sanitation and drainage services. Good quality, safe and clean water supplies, and attractive watercourses, which do not cause problems with flooding, are goals for any city of the future. To achieve this, the function and interaction of urban water cycles, water supply, drainage and river systems, and how they interact with society, must be understood. It is not the scope of this manual to go into the finer details of the urban water cycle or integrated urban water management since operational details of methods and tools are widely available. This manual has been written to show the direction needed to take forward the transitioning of water systems in a city.

The manual calls on a wide range of case studies from both within and outside SWITCH and uses four SWITCH cities to show how it can be applied.

There are SEVEN sections to the Transition Manual.

1. Setting the scene - The Background to Transitioning
2. The Transition Framework Explained
3. The Transition Management Cycle
4. Strategic Niche Management – The Demonstrations
5. Transitioning Stories from Four SWITCH Cities
6. Example Tools for Transitioning
7. Further information





## Abbreviations

BH	Belo Horizonte (city in Brazil)
BMPs	Drainage Best Management Practices (see also SUDS)
CBR	Cost Benefit Ratio
COTF	City of the Future
CP	Clean (Cleaner) Production
CWIS	City Water Information System (A SWITCH Product)
CWB	City Water Balance (A SWITCH Product)
CWE	City Water Economics (A SWITCH Product)
DRENURBS	Programme of urban drainage demonstration projects in Belo Horizonte, Brazil.
ECOSAN	Sanitary waste treatment approach using ecological systems – also a sub-project in SWITCH
EU	European Union
GIS	Geographical Information System
FP6	Research Project in the EU Sixth Framework Programme
GDP	Gross Domestic Product
KSI	Knowledge Network on System Innovations
IUWM	Integrated Urban Water Management
LA	Learning Alliance
MSE	Micro to small enterprise
NGO	Non-governmental organisation
NWRP	National Water Resources Plan
OECD	Organisation for Economic Co-operation and Development
RIDA	Resources, Infrastructure, Demand, Access
RWH	Rainwater harvesting
SAT	Soil-Aquifer treatment

SME	Small to medium enterprise
SUDS	Sustainable Urban Drainage Systems (see also BMPs)
SUDSLOC	Model for locating SUDS
SWITCH	EU FP6 Project Sustainable Water Improves Tomorrow's Cities Health
TM	Transition Management
TMC	Transition Management Cycle
WDM	Water Demand Management
WSUD	Water Sensitive Urban Design

## Glossary of Terms

Climate	The average weather conditions in a zone.	Natural systems	Environmental systems which are free (relatively) from human influences.
Climate change	The change in climate which, commonly, is attributed to increased emissions of greenhouse gases and not natural variability.	Niche experiments	Trials to determine the behaviour and applicability of an innovation in a new location.
Daylighting	Uncovering streams which have been piped and are unable to support biology.	Pluvial flooding	Local flooding arising from intense rainfall
Demonstration sites	Locations where the results of the SWITCH research were translated into tangible, socially-relevant demonstration activities.	Paradigm Shift	A radical change in thinking and implementing projects to a clearly different approach.
EcoCity	(also - city of the future; water sensitive city). A city which has a minimal impact on the environment (water in the case of SWITCH).	Resource availability	The availability of material or human resources available for a task or project
Ecosystem	A system where populations of species group together into communities and interact with each other and the environment.	Soil-aquifer systems	A method of purifying water and recharging groundwater by passing it through soil layers.
Fluvial flooding	Flooding arising from high river levels.	SUDS	(also BMP, WSUD) Methods of draining and capturing rainfall/ runoff which minimise the environmental impacts of development.
Governance	The way in which different institutions work together (to manage water services), and make decisions.	Transition Management Cycle	A sequence of steps (10 in this manual) to manage change while ensuring full stakeholder engagement.
Integrated urban water management	Development and implementation of a flexible strategy that simultaneously and holistically considers all areas of the urban water cycle as well as other urban management sectors.	Transitioning	A structural change in the way a society operates in which culture, markets, networks, institutions, innovations, policies, behaviours and trends evolve together from one relatively stable system state to another
Learning Alliance	An interconnected group of people and organisations in a city involved in action research which typically includes players from the public sector, utilities, regulators, educators, research institutes, the private sector and society in general.	Trans-boundary issues	Impacts such as pollution or flooding which have their origin in one state or region but cause effects in another.
Marine flooding	High sea levels and possibly tidal or wind surge causing inundation of coastal areas.	Water scarcity city	A city where the supply of water for potable, industrial or other uses is significantly less than the demand.
		Water resources	Traditional term for the provision of water for use following only basic treatment.
		Urbanisation	The progressive expansion of towns and cities into rural areas

## Manual structure

**Section One** outlines the main impacts of global change on urban water infrastructure, on the environment and on the population on a local and global scale and the potential sustainable and integrated solutions for the ‘city of the future’. The solutions are based on environmentally sound practices – technologies, energy efficient methods, natural treatment systems and many more - that are classed as ‘next generation’ systems, some of which have been under development or advancement in the **SWITCH** project. This section concludes with an overview of the transition concepts that have led to the development of the transition management cycle and strategic niche management concepts.

**Section Two** explains the logic, layers and components of the **SWITCH** transition framework, which is the result of analysing sustainable transition and strategic niche management processes and consolidating these with the **SWITCH** outputs. Application of each transition component or intervention is illustrated by showing how it was applied in the **SWITCH** demonstration cities. Learning Alliance activities are linked to and drive the sustainable transition management cycle which is at the core of the framework.

**Section Three** provides guidance on implementing the sustainable transition management cycle via transition clusters and steps. The activities are supported by examples from the **SWITCH** cities where a city has shown ‘strengths’ in an activity and successfully implemented part of the process. Transition Clusters are the key tools of the transition management cycle with the final cluster (next round of transitioning and visioning) closing the loop. Lesson learning and re-evaluating the process enable adaptations to agendas and visions, and the transition process continues.

**Section Four** provides direction for implementing strategic niche management processes. This is done through the application of the **SWITCH** tools for transitioning, many of which are **SWITCH** project outputs but including others that are relevant to transitioning. It is important that innovations are nurtured for the delivery of

sustainable urban water systems since they provide the scope and pathways for a transition to occur. The section also includes the city projects that demonstrate the niches where the innovations are located. Innovations do not occur by themselves, and many types of socio-technical transitions result from transition management and the creation of environments for innovative niches to grow. The niches considered in this manual focus on three key knowledge areas: technical, financial, and, governance/ institutions. These niches provide useful examples for transferring this knowledge to decision makers, managers and practitioners.

**Section Five** presents **SWITCH** Case Study ‘stories’ from four of the **SWITCH** cities - Accra in Ghana, Alexandria in Egypt, Łódź in Poland and Belo Horizonte in Brazil. The case studies show how a **SWITCH** transition is occurring, and might occur in the future. A city that will be facing change in the future should find these stories useful. An analysis of past water developments and the intervention in **SWITCH** was undertaken to see how the transition occurred or might occur in future. Barriers that blocked a transitioning trajectory are examined to identify the issues so that lessons can be learned and clearer ideas of what will work better can be formulated for the next transitioning round. Each city story includes a timeline for the years 2010 – 2033 based on this analysis to show how changes may occur in future.

**Section Six** introduces a number of decision support tools that have value in facilitating transitions in the cities. The tools cover a range of activities, from analysis of water and drainage networks through financial evaluation for cost recovery, to guidance on governance for micro-industries.

**Section Seven** includes references, background information and useful web-links.

## ACKNOWLEDGEMENTS

This book has been prepared within the framework of the European research project SWITCH. SWITCH is supported by the European Commission under the 6th Framework Programme and contributes to the thematic priority area of “Global Change and Ecosystems” [1.1.6.3] Contract no 018530-2. The authors also wish to thank the many SWITCH partners and collaborators whose research outputs are presented here.

The work of the following is sincerely acknowledged:

The work of the following centres is also freely acknowledged:

- The Centre for Water Sensitive Futures at Monash University, Australia.
- The Institute of Sustainable Futures, University of Technology, Sydney.
- The coalition for Alternative Wastewater Treatment, MA, USA.

## Disclaimer

This publication reflects only the authors' views. The European Commission is not liable for any use that may be made of the information it contains



The inner layer of the SWITCH Transition Framework, specifically the Sustainable Transition Management Cycle concept has been used in its entirety as the core activities for the transition of urban water systems. The transition management steps have been slightly adapted from the original concept for easier understanding by a non academic audience but the concept of clusters and steps for influencing a sustainable transition is solely attributed to academics / Directors from the DUTCH KSI network (Knowledge network for System innovations and Transitions). (Grin et. al. 2011).

The Manual would also not have been possible without the support of the University of Abertay Dundee.



# *Section 1*

## *Setting the Scene*

# SWITCH Transition Framework

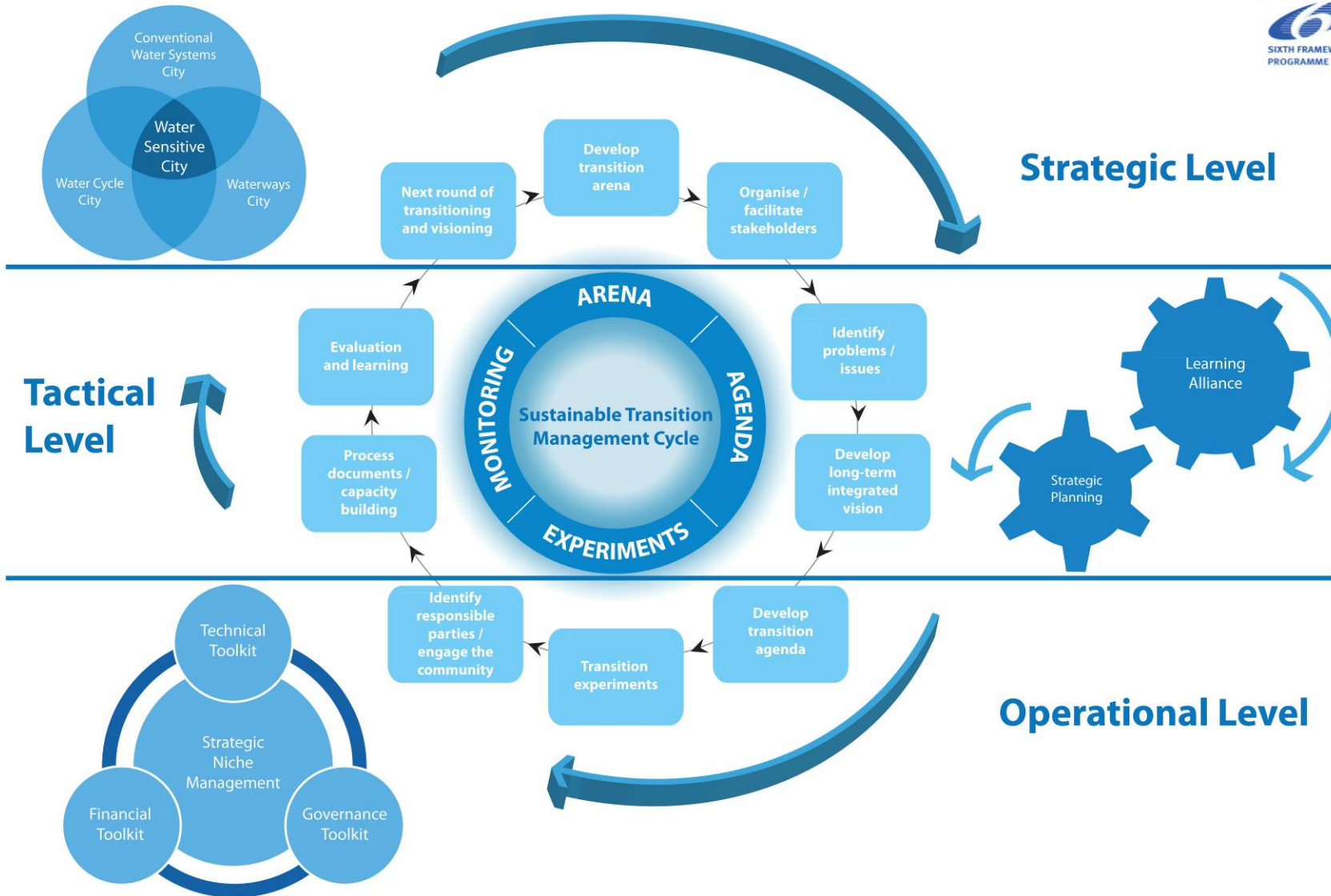

### Introduction

A transition in urban water systems is a structural transformation that can be defined as:

***‘a radical switch from conventional socio-technical systems to next generation urban water systems’***

It is accepted on a global basis that radical changes are necessary for achieving a more sustainable approach to urban water management. One of the major objectives of the **SWITCH** project was to deepen knowledge of integrated and sustainable urban water management to encourage a shift in urban water management practices towards more sustainable outcomes. Key **SWITCH** outputs are **Learning Alliance** demand-led research and **Strategic Planning** processes for the development and implementation of new techniques that will have a positive impact on the sustainable performance of water systems in cities. These approaches also incorporate fundamental transition management mechanisms for facilitating shifts in urban water management practices.

**SWITCH** was a short-term global socio-technical transition experiment over the five years 2005 - 2011. It attempted to guide and even accelerate the participatory processes required to move cities towards transitioning their urban water planning and operational practices in a very short timescale in transitioning terms.

The **SWITCH** project instigated a global learning environment combined with a transition management methodology that can be replicated in other cities. Using the **SWITCH** approach as a practical example the manual can be used to focus a city on sustainable transition end goals.

**SWITCH** attempted to facilitate the development of innovation through the dissemination of ideas between stakeholders and scientists within and between the cities involved in the project. This was intended to lead to the new ideas and methods being rolled out in specific areas (known as ‘niche take-off’) to the benefit of the cities. To be successful, the implementation of new generation urban water systems must be achievable and must deliver potential cost and efficiency savings alongside environmental benefits such as the enhancement of city landscapes, otherwise the new ideas will not be adopted. Improving the sustainability performance of a water system is inherently location-specific since different cities have different types of urban water systems operating to different standards. Each city will also have different aspirations for the future of these systems.

**SWITCH** encouraged the development of a broad range of innovations in a number of cities worldwide. In these cities, **Learning Alliances**, made up from government bodies, user groups and research institutions, led strategies that attempted to foster interaction between all levels of stakeholders and society. This involved nurturing new and emerging techniques to support the uptake of the technology into the cities. New ideas and methods often need protecting since they might be seen as being too radical

The **SWITCH TRANSITION FRAMEWORK** has been developed to aid in understanding the Transition process. At its core is the Sustainable Transition Management Cycle which is ‘driven’ by the Learning Alliance in the city. The framework illustrates the high level aspirations for a city and the way in which the tools – technical and organisational - are applied in particular areas (or niches) to provide answers to detailed questions about the future performance of urban water systems.

The transition framework is the result of analysing sustainable transition and strategic niche management processes from transitions in existing literature, and consolidating these with the **SWITCH** intervention in order to better guide a change towards sustainable urban water management outcomes in cities. Achieving sustainability goals will support the process of displacing dominant infrastructures and embedding more sustainable systems into society over time.

The **SWITCH** transition framework is not meant to be a deterministic tool to predict the course of a transition. This manual is a guide to the underlying driving forces and mechanisms behind the processes and actions that may influence a change.

The main appeal of transitioning is that it is a fresh approach to dealing with the complexities of the conventional urban water dilemma. Transition and associated strategic niche management approaches aim to influence and accelerate a **SWITCH** to more sustainable practices by; deepening knowledge through social learning; broadening experiences by experimentation with innovative ideas and techniques, and; scaling up to embed the new ideas and processes by gaining support and involving key players. These are also essential components of the **SWITCH** intervention for delivering the shared vision of urban water services and systems that can meet the challenges of the city of the future.

The **Learning Alliance** drives the activities related to the sustainable transition management cycle. These activities involve building transition agendas and strategic plans derived from collaborative visioning and scenario planning exercises. The **Learning Alliance** is the main stakeholder group which nurtures innovative technologies and practices which are linked to strategic niche management processes.

Innovations do not occur by themselves, and many types of socio-technical transitions result from the creation of suitable environments which encourage innovative niches to grow. A key success of **SWITCH** was the creation of space by city **Learning Alliances** for demonstrations to develop in the cities.

Many tools can be used to assist with transitioning. Ten example tools arising from **SWITCH** demonstration research outputs and other projects are included in the manual to show how the new ideas and methods can be managed and evaluated in their niches. The tools focus on three key knowledge areas (technical, financial and governance) and are presented in section six of this manual.



**Alexandria – a world city beside the sea**



### What's the problem - Why SWITCH from the old paradigm?

The current (or old – depending on the viewpoint) paradigm in operating and improving water systems was born from meeting the needs of developing societies. Although great technical innovations were developed to meet these needs, these same technological innovations are now causing problems. Many changes are highly desirable to meet current needs and standards, indeed they are often urgently required. However, they can only be achieved if they fit in with the existing infrastructure, are affordable, and can be operated within the local context and by the local institutions. Demand for change can be driven by issues which include:

- **Ageing infrastructure.** Many water supplies, sewers and treatment plants have been operating in excess of 100 years. Pipes leak, they collapse and sewers overflow.
- **Energy costs** rise continually and pumping water is becoming increasingly unaffordable, particularly in many drainage systems with large amounts of unwanted surface water.
- **New technologies** and new issues such as the availability of new measuring devices or components which will make systems more efficient.
- **Groundwater** resources have become depleted or polluted in many urban areas of the world.
- **Pollution** of lakes, rivers and groundwater is increasing.
- **Urbanisation** causes additional stresses on existing systems. Solutions tend to be short-term and ad hoc and are generally only partial and expensive to operate.

- **Migration** to cities is increasing, particularly in developing countries, causing demands on water to expand relentlessly.
- **Climate change** is already impacting on cities in catastrophic ways in terms of increasing droughts and floods.
- **Escalating costs** of project implementation, operation and maintenance.

There are many problems with water systems and networks which could be resolved better. However, for a sustainable future, sustainable solutions need to be found now so that present issues are resolved without creating future problems.

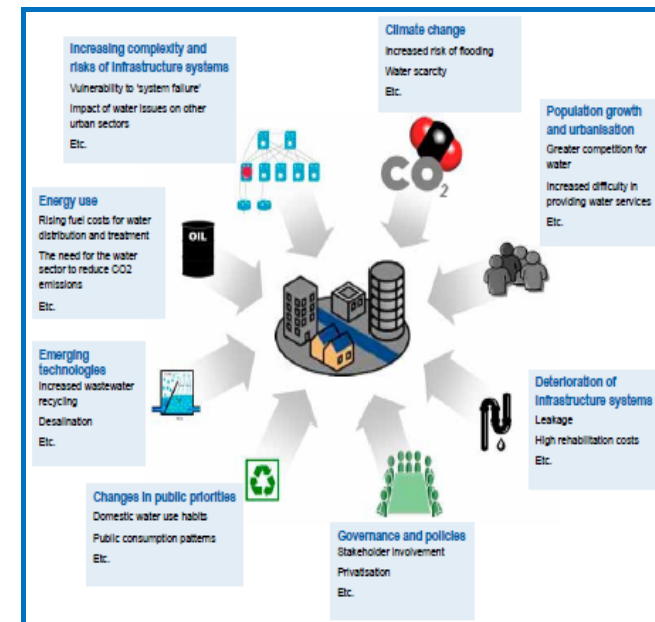

Preparing for the future - Strategic planning and IUWM

There are many continuing questions about present issues in the planning and management of water systems. There are significant differences between cities but a number of more general problems may be noted in many cities:

- **Poor governance** and a lack of integration in urban water policies characterises many current approaches to urban water management.
- **Water surplus/ deficit in cities** – some are in water deficit, some are in surplus. Most cities also have water quality and pollution problems.
- **Developed cities and developing cities.** Many cities are in transition economies - where the economy of the country is changing from being centrally planned to a free market. There are others with very mature economies where the population may be falling and solutions may not be affordable. The nature of the city and state economies will strongly influence how change occurs.
- **Trans-boundary** water issues on international rivers such as the Nile and Niger in Africa and the Mekong in Asia.
- **Barriers to change** - Infrastructural dependency, socio-economical and cultural factors can contribute to path dependencies which hinder change.
- **Water quality standards** are becoming increasingly stringent due to health awareness, changing public perception of the environment and legislation.
- **Energy** is required in many water industry applications, particularly in pumping. The greater use of energy intensive solutions increasingly depletes natural resources.

## Examples of the problems

### Implementing new water tariffs in Cali, Colombia

'there are problems with implementing tariffs that are affordable. This includes resources for expansion, operation and maintenance of services. There is also a lack of financial incentives in areas where the marginal cost is higher than the average. In addition, since there has been a reduction in subsidies, it has been impossible to charge the water use and water pollution fee in the water bill. Enforcement of the water pollution fee has been slow since its implementation with charges being made only to users that had any economic reward such as industries. Implementation at house level has not yet been possible and diffuse pollution is not considered. Livestock and agriculture activities are indirectly favoured'.

### The many issues and challenges in Accra, Ghana

- Rapid growth, especially in the city fringes.
- Development of slum areas.
- Poor access to water supply and sanitation services are poor.
- High distribution network losses.
- Polluted water resources.

### What can we do about it?

What will the new paradigm look like? What are the solutions? How can it be achieved?

The future is uncertain and presents serious and persistent problems – sometimes termed ‘wicked’ problems. Urban water systems need to be changed but uncertainty is hard to plan for especially in the context of ‘resilience and adaptability’. Systems need to be able to absorb local and global shocks such as from climate change and urbanisation.

To prepare for and make changes, diverse solutions must be sought that draw in partners from many disciplines and sectors of society. Where there are many partners, progress is made by imagining new futures that deliver systems that have an increased adaptive capacity with stronger sustainable performance than today. The overall approach is termed **Integrated Urban Water Management** (IUWM), which addresses the whole urban water cycle and delivers all-round benefits for society, the environment and economies.

Sustainable approaches may require a range of large or small changes and may need to incorporate new discoveries, environmentally sound technologies or next generation systems and techniques.

The changes needed are not only about new components. Often, means of communicating better are just as important. New decision making tools and ‘agents of change’ were developed in **SWITCH** for helping to better inform decision makers, including City Water Information System (**CWIS**), City Water Balance (**CWB**) and City Water Economics (**CWE**), which can all assist with planning and choosing future directions for a city.

Here are some examples of the new generation systems and approaches:

- New generation systems (The following **SWITCH** ‘Niches’ advanced innovations in some way.
  - ✓ Water reuse, rainwater harvesting, grey water recycling.
  - ✓ Ecosan and urine separation and use.
  - ✓ Waterless toilets.
  - ✓ Water saving devices.
  - ✓ Natural systems for treatment.
  - ✓ Soil aquifer treatment and aquifer recharge.
  - ✓ Sustainable drainage – green / brown roofs, wetlands, ponds, basins, permeable paving.
  - ✓ Urban agriculture.
- ‘Run to failure’ – a concept in asset management where it is efficient to stop repairing the old systems and eventually replace them with new generation systems (Nelson 2008).
- Decentralised household and community scale systems are being widely considered as an alternative response to the deficiencies of centralised approaches in many urban areas as they use less resources and are more ecologically benign (Van Dijk & Liang 2009).

## What is the new paradigm?

The requirements for the urban water systems of a city of the future (COF) have been described by Novotny and Beddow (2010):

*“The new paradigm must include consideration of energy and green house gas emission reductions and treat stormwater and reclaim used water as a resource to be reused rather than wasted, requiring costly disposal that can further damage the environment. Therefore, the COFs will combine concepts of “smart/green” developments and the landscape with natural systems and controls of pollution and stormwater flows from the landscape. They will reuse highly treated effluents and urban stormwater for various purposes including landscape and agricultural irrigation, groundwater recharge to enhance groundwater resources and minimise subsidence of historic infrastructure; environmental flow enhancement of effluent-dominated and flow deprived streams; and for non-potable water supply. The organic content and energy in used water will be treated as a recoverable resource along with reclamation and reuse of urban stormwater.”*

The authors explain the need to implement water conservation measures and change the current linear system of not just water management but the entire urban metabolism of a city to a cyclic (decentralised) system. This would not only save water and energy and be less polluting, but it would also be attractive to developers and city planners and desired by the public. *“This paradigm of urbanisation is based on the premise that urban waters are the lifeline of cities and the focus of the movement towards more sustainable cities.”* (Novotny and Beddow (2010)).

*An ecocity is a city or a part thereof that balances social, economic and environmental factors (triple bottom line) to achieve sustainable development.* (Novotny and Beddow (2010)).

The differences between the current unsustainable urban water practices in existing cities and the cities of the future are cited in Table 1. A city of the future may also be defined as an “EcoCity”. COF will only be achieved with a major paradigm shift by building or retrofitting cities in a new way in order to achieve the **SWITCH** required away from the current unsustainable status.



**Water will be more accessible in the city of the future? These Japanese children are looking at fish in a stream beside the street**

## Section 1 – Transitioning – Setting the Scene

Table 1 gives an outline of the degree of decentralization and cluster management which will help in moving towards future hydrologically and ecologically functioning ecocities.

**Table 1. Comparison of Traditional and Cities of the Future Concepts (Fifth Paradigm), Adapted from Novotny and Brown (2007)**

Traditional	Cities of the Future
<b>Drainage:</b> Rapid conveyance of stormwater from premises by underground concrete pipes or culverts, curb and gutter street drainage	<b>Storage oriented:</b> Keep, store, reuse & infiltrate rainwater locally, extensive use of rain gardens, drainage mostly on surface.
<b>Wastewater:</b> Conveyance to distant downstream large treatment plants far from the points of reuse.	<b>Local reuse:</b> Treat, reclaim and keep a significant portion of used water locally for reuse in buildings, irrigation and providing ecological low flow to streams.
<b>Urban habitat Infrastructure:</b> No reuse, energy inefficient, excessive use of water.	<b>Green buildings :</b> water saving plumbing fixtures, energy efficient, larger buildings with green roofs.
<b>Water, stormwater/wastewater infrastructure:</b> Hard structural, independently managed.	<b>Local cluster decentralized management:</b> soft approaches, best management practices as a part of landscape, mimic nature.
<b>Transportation, roads:</b> Overloaded with vehicular traffic and polluting.	<b>Emphasis on less polluting fuel:</b> bring living closer to cities, good public transport, bike paths, best management practices to reduce water pollution.
<b>Energy for heating and cooling:</b> Energy brought from large distances, no on-site energy recovery, high carbon emissions	<b>Energy recovery and reduction of use:</b> Part of heat in wastewater recovered & used locally, biogas from waste, use of geothermal, solar & wind energy.
<b>Overuse of potable water:</b> Drinking water is used for all uses, losses in distribution system.	<b>Use of treated drinking water:</b> from distant sources should be potable use only, re-use water more, reduced losses in distribution.
<b>Economies of scale:</b> in treatment cost and delivery is driving the systems- the bigger the better.	<b>Triple bottom line pricing and life cycle assessment:</b> of the total economic, social and environmental impact
<b>Community expectation of water quality:</b> distorted by hard infrastructure such as buried & fenced off streams for flood and/or effluent conveyance.	<b>Daylighting and/or renaturalization:</b> of the water bodies with parks connecting with built areas enhances the value of the surrounding neighborhoods and brings enjoyment

Decentralised systems address water issues as close as possible to their point of origin – drinking water is produced locally, wastewater is treated locally. Potentially, distributed systems can give significant environmental benefits, the most obvious being the energy saved by avoiding major pumping costs. Unfortunately, the cost and management models of most water utilities favour centralised systems. The merits of each are addressed in Table 2.

**Table 2. Decentralisation and cluster management Adapted from Daigger (2009) by Beddow (2009)**

Component	Centralised	Distributed/decentralised in clusters
<b>Stormwater management, rainwater harvesting</b>		BMPs – pervious pavements, rain-gardens, green roofs, surface & subsurface storage, infiltration basins and trenches.
<b>Water conservation</b>	Reducing or replacing leaking pipes, education of citizens about water conservation, dual water distribution.	Wide variety of commercial water saving plumbing fixtures and technologies for potable and non-potable use; changing from lawns to xeriscape.
<b>Treatment</b>	Treatment for potable use and non-potable reuse.	Treat for local potable use (from local wells and surface sources) and non-potable reuse in small cluster size water and energy reclamation units; stormwater and effluent treatment in biofilters, ponds and wetlands.
<b>Energy recovery</b>	Methane from anaerobic treatment and digestion of residual organic solids, Thermal microbial fuel cells Electricity from methane.	Capture and distribution of heat and cooling energy (heat pumps); geothermal, wind , and solar energy. Biogas production by digestion.
<b>Nutrient recovery</b>	Land application of biosolids, Struvite (ammonium magnesium phosphate) precipitation and recovery.	Irrigation with reclaimed water with nutrients left in it; reclaimed irrigation water distribution to parks, golf courses and homeowners.
<b>Source separation</b>	Treatment of black wastewater and organic solids with energy (biogas) production.	Supply potable & non potable water; Treat black, grey (laundry and kitchen), and yellow water for irrigation & toilet flushing.
<b>Landscape management</b>	Habitat restoration; fish management and restocking, wild life management in ecotones.	Stream and ecotones maintenance, installation and maintenance of BMPs, including ponds and wetlands; on and off water recreation.

## What is transitioning?

Transitioning is a concept that aims to influence the structural change of complex systems over time by experimenting and implementing new technologies.

A transition in the urban water context is a structural transformation. It is a radical switch from conventional socio-technical systems to next generation integrated and sustainable urban water systems.

The 'socio-technical systems' or 'complex systems' that we want to transition are the urban water systems that provide our cities with water supply, sanitation and drainage services. Good quality, safe and clean water supplies, and attractive watercourses, which do not cause problems with flooding, are goals for any city of the future. To achieve this, the function and interaction of urban water cycles, water supply, drainage and river systems, and how they interact with society, must be understood. It is not the scope of this manual to go into the finer details of the urban water cycle or integrated urban water management since operational details of methods and tools are widely available. This manual has been written to show the direction needed to take forward the transitioning of water systems in a city.

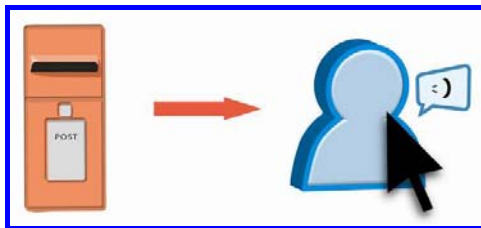

Email – a Transition from the postal system to electronic mail

Transitioning stems from a growing urgency for things to be done differently. Conventional urban water management practices the world over are proving to be un-sustainable in the face of persistent global pressures such as climate change and increasing urbanisation.

The outputs of **SWITCH** provide a fresh approach that can engage with the complexities and limitations of conventional systems and practices, and develop new generation systems. The process of transitioning analyses old systems with a view to influencing the implementation of new ones over a relatively long timescale. Four different approaches to transitioning are considered in this manual, each concept having a different focus but they are intrinsically linked.

The approaches are: the **multi-phase concept**, the **multi-level perspective**, **transition management** and **strategic niche management**.

The multi-phase and multi-level concepts are introduced in this section to provide an initial description of the different phases, the timescales involved and relationships between functional levels associated with transitions. Both are considered in more detail in section 5 of this manual.

## The Multi-Phase Concept

The multi-phase concept is an explanatory framework which broadly considers the dynamics of transitions over time as a series of phases, which shift from one phase to another. This is a process whereby culture, markets, networks, institutions, technologies, innovations, policies, behaviours and 'trends' evolve together from one relatively stable state to another.

## Section 1 – Transitioning – Setting the Scene

The transition pathway begins with the pre-development phase and the transformation away from the old system or set of processes. In the pre-development phase, changes happen slowly as innovative ideas that can address the persistent problems begin to be absorbed by stakeholders, scientists and society.

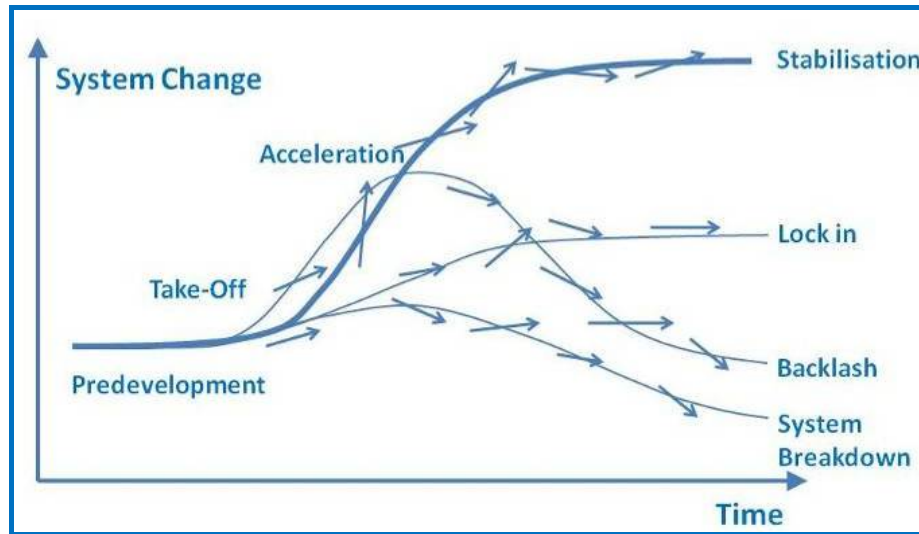

**The Multi-Phase Concept after Grin, Rotmans & Schot (2010)**

During the take-off and acceleration phases, new generation systems resulting from new ideas begin to be implemented. This will involve the interaction between stakeholders and is a period of rapid and unstable development. There may be many opportunities for making money during the take off phase since investment in the water sector will increase so this is likely to be a time of exciting activity when new developments are taking place.

The stabilisation phase sees wide-scale structural changes taking place as new systems become relatively stable again as their new

innovations and methods become widely accepted. The stabilisation phase signifies business as usual with new generation systems. After stabilisation, the water utilities, for example, may look the same but their operations and activities might be very different and of course environmentally more sustainable.



**The Urban Water Cycle (source pacificwater.org)**

The process can be visualised as an S curve which generally indicates a growth phase but, while the S curve is the ideal transition scenario, in reality this is often not the case. The S curve implies smooth change, whereas there may be a start-stop process, or more pessimistically, lock-in, backlash or even system breakdown may occur.

System lock-in occurs when an emergent technology becomes embedded or path dependent. When this occurs, new opportunities and innovations might become excluded due to, for example, perceptions of increased costs or resistance from stakeholders who fear a change to the existing status quo. Once an institution or community decides not to accept a change, the uptake of new systems can be blocked. This scenario is particularly relevant in the water sector where improvements to infrastructure entail large investments and specialised skills.

System backlash occurs when innovation advancement is stifled at a time when the emerging technology is still immature resulting in a loss in momentum. System breakdown occurs when there is insufficient knowledge or stakeholder support for the new technology resulting in a reverse trajectory and system collapse. For example, if new pumps that need excessive maintenance are supplied to a city water department with little money or trained staff, they will fail, and the system will break down because it is not maintained.

There are several reasons for studying the multi-phase concept and the dynamics of historical transitions. For example, insights into how systems become locked in assists understanding of persistent problems. Whole-life cycles of systems innovations can be studied and theories developed to inform future urban water practice and implementation of innovations. Reflecting on the past (back-casting) helps identify where mistakes were made and provides insights into what went wrong and why it went wrong. Lessons can then be learned in order to go forward (or forecast) with a clearer idea of what will work better.

The dynamics of historical transitions and trends in some of the **SWITCH** cities are considered in more detail in Section Five of this manual.

## Multi-Level Perspective

The Multi-Level Perspective considers interactions between processes at different socio-technical levels known as the micro, meso and macro levels in transition theory.

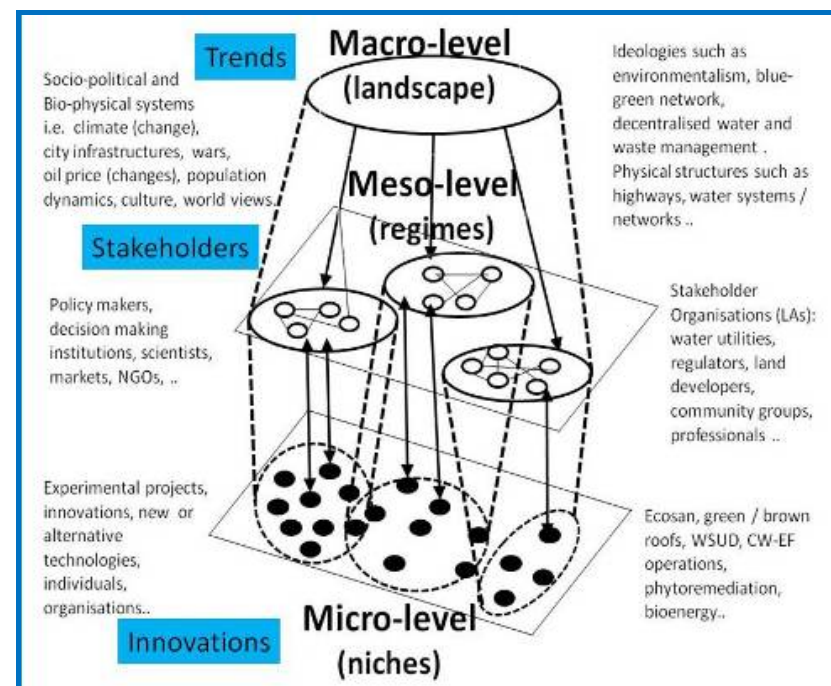

The Multi-Level Perspective based on Geels and Kemp (2000)

The Multi-level concept recognises that the macro level is the broad cultural, political, natural-environment view of a city that plays a significant role in accelerating or slowing down a transition. For example, this might either be through inertia at the political level, or uptake at the cultural level of new philosophies, processes or ideas.



## Section 1 – Transitioning – Setting the Scene

The process of implementing innovative technologies should be aligned with existing trend or 'landscape' issues such as cultural and socio-economic factors.

In the context of the Multi-level perspective, the new generation urban water systems will include, for example:

- The physical network of optimally configured water supply and sewer networks and open or closed pipes for drainage (Macro);
- The cultural and political context of the people requiring the service (this is the landscape) (Macro).
- The organisation and management that installs, improves and operates the systems (these are regimes) (Meso), and;
- Niches (Micro), which might also include green roofs and walls, as in the example in Berlin below.



Green roof to garage below

Green roofs and walls in Berlin

Before the necessary elements of the transition can be identified, a stakeholder platform (the Transition Arena) and the **SWITCH Learning Alliance (LA)** should be created. The LA involves key members who will represent the diverse set of professions involved in making decisions in the city.



Learning Alliance sessions in Alexandria, Egypt

### Actions to develop the Integrated Urban Water Management (IUWM) strategy in Alexandria – typical of an activity at the MESO level

- Results from strategic studies are major inputs to the plan.
- All existing plans are being studied so that the IUWM plan goes in line with them (NWRP, Alexandria water and Wastewater Master plan 2037).
- A study has been made to assess Nile Water availability in 2037 so that the degree of dependence on unconventional water resources is known.
- A significant contribution from the Learning Alliance.

## Transition Management

Transition Management (TM) is a strategy where past and current urban water systems are evaluated to influence the achievement of a longer term sustainable vision for urban water management practices in a city.

Transition management focuses on uncertainty, learning by doing and doing by learning, and the organisation of processes that look at several solutions to reach a goal.

The distinguishing characteristics of Transition Management (TM) are intrinsically linked to visioning processes for long-term outcomes and use the concept of sustainability as their guiding principle. The combination of theoretical and analytical insights into the complexity of systems such as the urban water cycle, and the application of a 'governance' approach to address these complexities has resulted in the management framework in Table 3.

This management approach has been translated into a practical management framework termed the **Transition Management Cycle (TMC)**. TMC involves long-term planning through small steps based on learning and experimenting so the process is cyclic and iterative. The cycle consists of four co-evolving activity clusters:

- **Transition Arena** where problem structuring takes place
- **Transition Agenda** - developing the strategic plan and sustainable pathways;
- **Transition Experiments** – initiating and implementing innovations, and;
- **Monitoring, Evaluating, Learning** - lesson learning and re-evaluating for adjustments in the vision and agenda closing the loop to make the process cyclical.

**Table 3. Linking complexity characteristics, principles and systemic instruments for transition management (Loorbach 2007)**

Complexity characteristics	Theoretical Principles TM	Systemic Instruments for TM
Emergence	Creating space for niches	Transition arena
Dissipative structures	Focus on frontrunners	Transition arena and competence analysis
Diversity and coherence	Guided variation and selection	Transition experiments and transition pathways
New attractors, punctuated equilibria	Radical change in incremental steps	Envisioning for sustainable futures
Co-evolution	Empowering niches	Competence development
Variation and selection	Learning by doing and doing by learning	Deepening, broadening, scaling up experiments
Interactions, feedbacks	Multi-level approach multi-domain approach	Complex systems analysis
Patterns, mechanisms	Anticipation and adaptation	Multi-pattern and multi-level analysis

In practice, transition management activities may be carried out in any sequence. The activities may be carried out partially, completely, in sequence, in parallel or randomly (Grin et. al. 2010). The Transition Management Cycle and activity clusters are considered in more detail in section 3 of this manual.

## Section 1 – Transitioning – Setting the Scene

### Transition Management Levels

'Levels' in transition management should not imply a hierarchy. Transition management levels (strategic, tactical and operational) are a mechanism or learning tool based on experience that provides a structure to implement the TM process. They constitute forms of governance activities that influence each other and operate together.

Table 4 illustrates the differences between the activities and the timescales involved. One of the aims of transition management is to develop adaptive and anticipatory governance systems that systematically influence, guide and structure governance activities over time.

**Table 4. Transition management activity types. (Loorbach 2007)**

Management Level	Problem Level	Time Scale	Systems Level
<b>Strategic</b>	Abstract / societal system	Long-term (30yr)	System
<b>Tactical</b>	Institutions / regime	Mid-term (5-15yr)	Sub-system
<b>Operational</b>	Concrete / project	Short-term (0-5yr)	Niche / mini-system

Transition management levels are not the same as the functional levels described in the multi-level perspective. Different types of actors participate at each management level, and a diverse set of competencies and skills is required across all levels. It is also necessary to acknowledge not only the influence of all actors on societal change processes but also to value the various

perspectives and diverse knowledge that can be utilised during all phases of the transition management process.

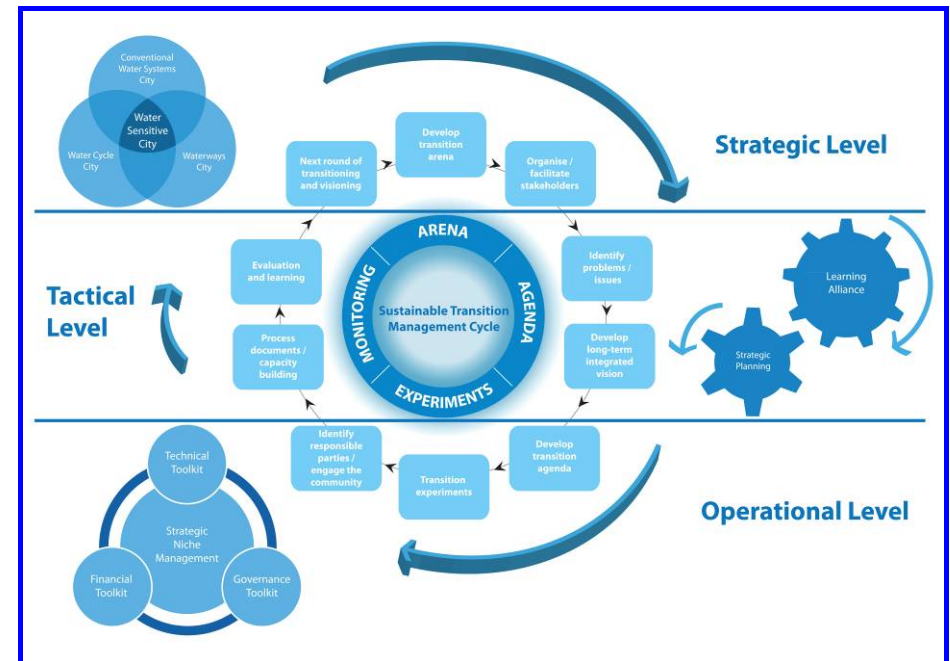

**Transition Levels (after Smith & Stirling 2008a)**

## The Strategic level

### The Strategic Level: Visioning and strategic discussions

At the strategic level, long-term goals are formulated, collective goal and norm setting is debated and long-term anticipation of innovative outcomes takes place. This level considers all issues that relate to the culture of the society and the existing state of play of the socio-technical systems in the city. These issues include debating the cultural norms, identities ethics and values that exist in the city plus anticipating the local requirements of sustainable urban water systems and the relevant importance to the city. This use of visioning processes can be viewed as a top-down form of guidance.

The strategic level will also include the manner in which international regulations (for example EU Directives such as the Water Framework and Floods Directives) will be implemented.

Visioning takes time and many Learning Alliances in **SWITCH** took several years before their city visions were finally developed. The vision requires the collaboration of actors at different levels who are able to understand societal uncertainties, power-relations and institutional barriers (Grin et. al. 2010).

#### Vision

A vision is a short summarised statement of a desired future; this vision has to be shared and agreed upon by all decision makers and stakeholders. The vision should be framed in a way that clear objectives can be set.

## The Tactical level

### The Tactical Level: Multi-stakeholder platforms and strategic planning

Societal sub-systems (the different elements of the urban water system) are the focus at the tactical level. This is where activities such as inter institutional networking, negotiations, planning and financing are organised. Responsibility for urban water systems usually rests with different institutions, organisations and actors and the relationships will be different in different cities and different countries. Activities at this level focus at achieving the short-term strategic goals of the vision and transition agenda.

Institutional fragmentation and the lack of integrated, strategic policies at the governance level are major barriers to integrated urban water policies and subsequent management of the urban water cycle in a city. Stakeholders at this level promote change in the different organisations to facilitate the uptake of new practices and innovations within their own agendas in spite of this fragmentation. Changes at this level might be the removal of existing barriers such as regulations and financial arrangements or developing new regulations and practices.

Champions are an important ingredient to facilitating institutional changes. In effect they are 'governance entrepreneurs' who possess the skills and the will to encourage change in a sustainable direction. They can gain managerial support and create opportunities for a transition to occur within the institution (Loorbach 2007).

## The Operational Level

### The Operational Level: Transition Experiments, Strategic Niche Management and Tools.

Short-term actions, experiments and innovation projects take place at the operational level. The development and implementation of new practices can provide a breeding ground or niche environment for establishing and scaling up the new activities into clusters of routines and structures at the institutional / regime level.

The transition agenda is developed through the collaboration of actors at different levels who are able to formulate joint goals and develop common strategies. Two examples of **SWITCH** niches at the operational level are given on this page. Many more are included in sections 4 and 6 of this manual.

#### Rainwater Harvesting In Beijing – A niche demonstration project

Capturing rainwater for irrigation of crops, using the roof of greenhouses in Beijing since June 2005. Agriculture is the largest water user in Beijing which is 70% reliant on groundwater.

Rainwater harvesting (RWH) using greenhouses is sponsored by the Beijing Agricultural Bureau via its service extension offices.

The SWITCH demo project in Beijing supported RWH by analysing water flows, cost/benefit analysis of typical farming systems, and by working with a Fruit Co-operative to link activities such as mushroom production and agro-tourism.

One of the **SWITCH** Demonstration projects in Belo Horizonte, Brazil developed a new tool for rainwater harvesting design. This is another example of a niche project at the Operational Level.

**Computing the optimal tank size**

Empty tank vs time | Cost | Rejected water vs size | Rippl diagram

Data | Data (2) | Savings | Water substituted | Water non substituted | Empty tank vs size | Mensual consumption | NPV vs time | NPV vs size

Type  
 School  
 Household  
 Customised

Please indicate surfaces in m<sup>2</sup>

Runoff coefficient: 0.83

Surface of the roof: 1990

Surface of grass: 1190

WC type  
 Type de toilettes  
 valve  
 tap

Rainfall data: [ ] B

Information:  Hourly  Daily

Time period (years, < 14): 14

Number of people

	Students	Professors	Staff
Period 1	960	24	15
Period 2	960	24	15
Period 3	150	4	3
Total during the week-end	290		
Total during holidays	360		

The school opens during holidays?  Yes  No

Surfaces (m<sup>2</sup>):  
 Surface of the kitchen garden: 0  
 Classrooms' total surface: 1355  
 WC's total surface: 260  
 Playground surface: 1325  
 Surface of the stairways and corridors: 720  
 Surface of the outdoor sport yard: 920  
 Surface du parking: 0  
 Canteen's surface: 240

#### New tool for rainwater harvesting design from Belo Horizonte

The primary goal at this level is to acquire knowledge and learning about the potential for the innovation to assist in achieving a transition, i.e. how can the long-term goals of the sustainable vision be realised? Experimentation with innovations can be seen as a bottom-up approach to transitioning.

## What might a transition city look like?

Several cities in different countries have made transitions in their infrastructure – in water services, in drainage provision and in transportation. In an ideal world, the whole infrastructure of a city would be transformed into a place that is environmentally in balance. However, more frequently, one critical issue is addressed because an urgent problem must be solved and the transition is in one sector alone.

Here are some examples in cities and regions where transitions have taken place or are in progress.

Hammarby Sjöstad is a suburb of Stockholm which claims to be one of the highest profile examples of sustainable development in a city. Detailed and integrated schemes have been developed for energy, water and sewage and waste and recycling and the 'Hammarby Sjöstad model' has been developed.



Hammarby Sjöstad, Stockholm

An information centre has been set up to provide advice to citizens. This is an important showcase suburb reportedly visited by more than 10,000 decision makers and specialists per year to see and understand the value of integrated environmental planning and management.

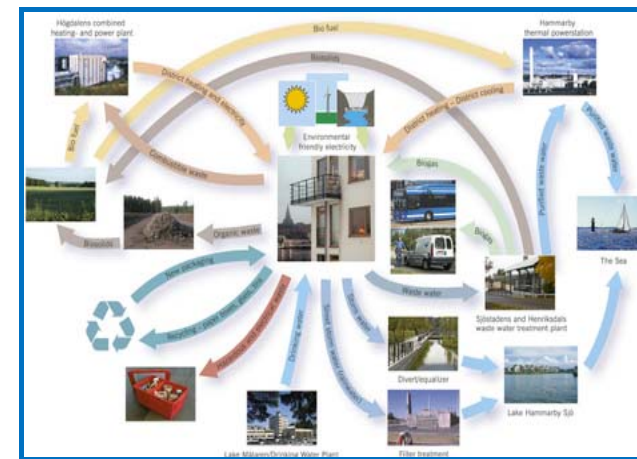

The Hammarby Sjöstad Model

The Hammarby Sjöstad model, or eco-cycle model is used to track energy, waste, and water in an urbanised area. The model shows how sewage processing and energy systems interact and illustrates the added-values society gains from modern sewage and waste processing systems. This is a city that '*considers every aspect of life and pushes the envelope on sustainable development*'. (jetsongreen.com).

Although 'ecocities' ('eco-suburbs' may be more accurate) such as Hammarby Sjöstad are excellent examples of what can be achieved with good city planning, transitions more commonly occur in one sector only, good examples being found in the fields of communications, transportation, energy and of urban drainage.

Curitiba, Brazil has made transitions particularly in the development of its public transport system in which buses follow special separates roads more akin to tram or train tracks to the city centre from the suburbs. A very flexible and cost effective transport

## Section 1 – Transitioning – Setting the Scene

system has been developed that has been replicated in other cities such as the 'Transmilenio' in Colombia's capital city, Bogota. The buses follow special tracks into and within the city centre from terminals in the suburbs.



**Transmilenio, Bogota, Colombia**

In Europe, transitioning is underway to address surface water problems through the use of sustainable urban drainage systems (or SUDS). In Scotland, new development is adding to a legacy of flooding and poor water quality in lochs and rivers. The conventional drainage system based on pipes taking the water away from roads, roofs and houses has been found to be inadequate to meet new criteria – particularly the standards in the EU Water Framework Directive.

SUDS (BMPs in the USA) slow down and treat the drainage water before it is discharged into a water body. This has required a paradigm shift in thinking to make space for water above the ground in ponds, basins and swales. New legislation was enacted in 2006 in Scotland, and 2010 marked fifteen years of progress in a process which normally takes between thirty and fifty years.



**A major development in Scotland – 350 Ha in area**

In northern Germany, a similar transformation is underway to protect and improve water quality in lakes and groundwater for drinking water and for leisure purposes such as swimming.



**Roadside swale, Berlin, Germany**



**Green roof, Hamburg, Germany**

## Examples of moving towards the new paradigm in SWITCH

**SWITCH** cities have given us many fine examples illustrating ambitious future city visions and highlighting successful practice in the context of their culture, climate, geography and infrastructure. For example, in Accra, Ghana, significant progress was made in developing a vision for water in the future. This was an essential first step to more integrated water management. In Belo Horizonte, Brazil, there are particularly good examples of educating local communities through local schools, music and dance.

### Accra Visions and Goals for Urban Water Management (2030)

- 100% access to uninterrupted water supply
- Maximum 10-15% physical losses and 10% commercial losses of drinking water.
- Efficient use of water by consumers
- Quality of surface water to meet Ghanaian standards
- Improved productive uses of water for livelihood
- 50-80% of waste material recycled
- Accra to be a clean city with drainage canals and streets free of garbage
- 80% of citizens to follow good sanitation practices
- Integrated and sustainable waste management system
- 70 % reduction in the incidence of diseases associated with water and sanitation
- 100% of sanitation facilities at an acceptable level (healthy, clean, dignified, safe)



The **DRENURBS** demonstration project in Belo Horizonte – showing a new way of surface water management by constructing new infrastructure AND involving the community.





## Section 1 – Transitioning – Setting the Scene

The informal settlement of Ma'awa Sayadeen in Egypt was the location of a major demonstration of social inclusion. This fishing village in Alexandria historically had good access to water but the leakage rates were very high. The location was a demo. site for water demand and wastewater management.



Stakeholder meeting, Ma'awa Sayadeen

In Łódź, Poland, great progress was achieved setting up systems for the improvement of the urban watercourses. In this example of strategic niche development, strategies were identified, plans drawn up and demonstration projects were undertaken.

The schematic below was sketched as part of a 'buy in' diagram for stakeholders showing the need for scaling up. It represents the city of Łódź and the many streams which are impacted by the urban area. In Łódź, stormwater is a resource, not a threat!

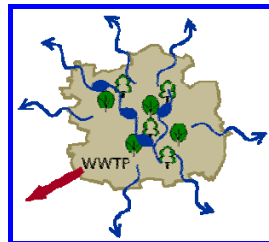

Schematic of the different rivers to be improved in Łódź

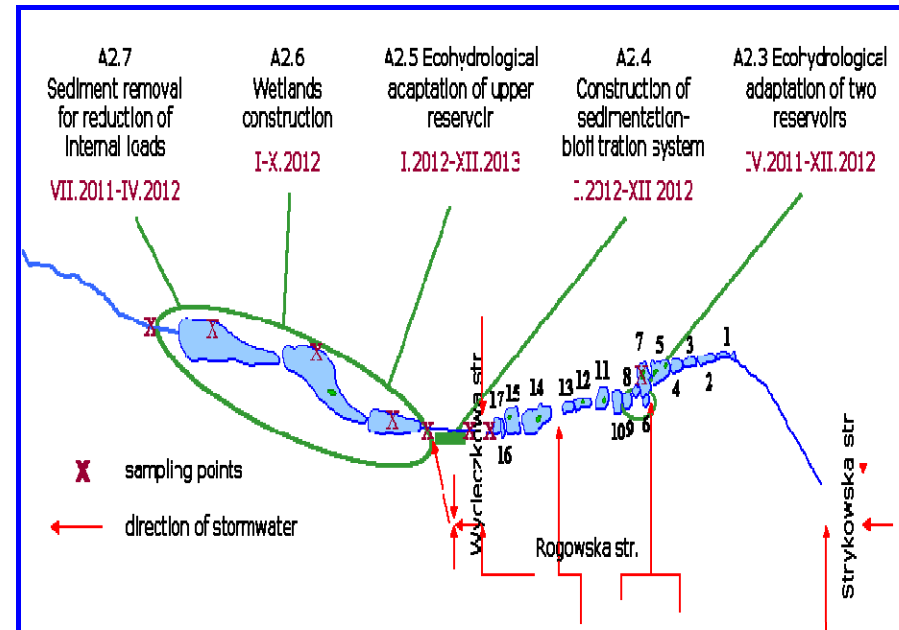

Guidance developed as part of a model approach to rehabilitation of urban reservoirs in Łódź

In Łódź, guidance was developed in considerable detail, as shown in the plan above which was drawn for a demonstration project. This level of detail is needed to enable projects to be evaluated fully and then implemented for scaling up experiments across the city to take the transition process forward. Detailed plans enable local authorities and developers – who can use them in their development planning - to understand the extent of the commitment to the implementation of new ideas and processes.

Łódź has also provided a good example of a **SWITCH** Learning Alliance in action. **SWITCH** introduced the principle of the **Learning Alliance (LA)** into urban water management. More information about LAs can be found in Section 2 of this manual. The Łódź LA brought new ideas, techniques and innovations into a city. The LA can operate at national, city and local levels, enabling it to view the essential components required to implement the transition.



**SWITCH Learning Alliance in Łódź**

In the city, the LA may commission projects that demonstrate to other decision makers the implications of the transition being promoted. The LA will also have good contacts at a neighbourhood level. The buy-in of local residents is particularly important since they must own and live with the changed water systems.

**Views of Łódź LA members on their LA**

- First attempt to improve communication between the different organisations and to provide a cross-institutional platform to share information and discuss water and sanitation issues.
- Gives an overall picture of how things work together in the city.
- Helps address the issues in an integrated way.

Class A	Class B	Class C	Class D
Zone where conservation has highest priority	Zone where conservation has high priority	Zone where recreation has high priority	Zone where recreation has highest priority

**Priorities for zoning at Wilhelmsburg, Hamburg**

A typical LA activity is to determine local priorities. A good example was noted in Wilhelmsburg Hamburg where more land was required for occasional flooding and the stakeholder priorities were used to draw up detailed plans. The views of local residents were used to match the functional requirements of land needed for flood control with competing land uses including conservation and recreation.

Embedded within **SWITCH** were a number of projects to develop or improve novel processes. These are the strategic niches in the Transition Framework, one of which was the Eco-San (Ecological Sanitation) project.

The focus of Eco-san was the development of house drainage designs that use less water. Also, the related technical standards and decision support system were written.

Many innovations have an impact on the operations of the water utility. These must be set out and agreed before new technologies can be installed on household connections.

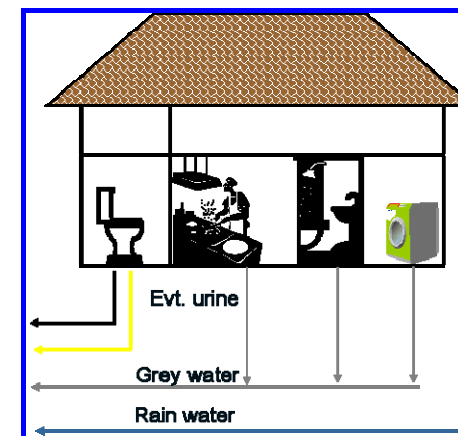

**Ecosan house drainage systems**

## *Section 2*

# *The Transition Framework Explained*

**Visioning**

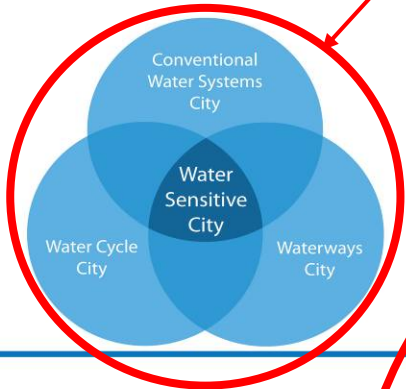

**The Transition Management Cycle**

**Learning Alliance**

**Strategic Level**



**Tactical Level**

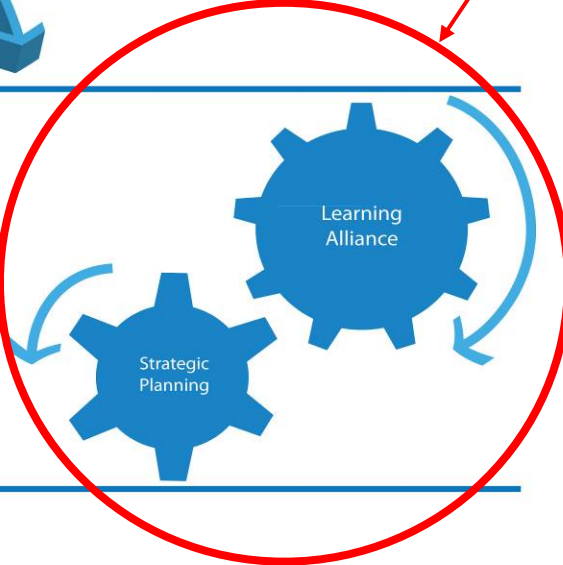
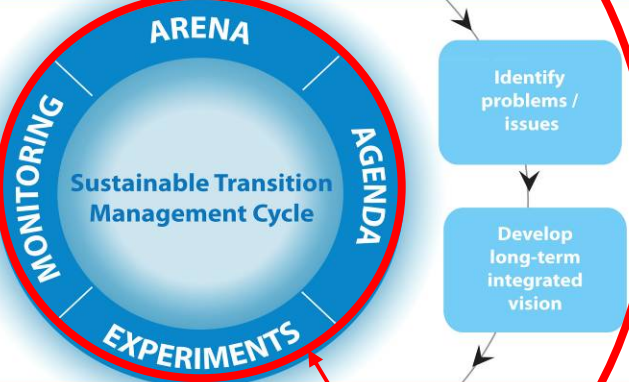

**Strategic Niche Management**



**Operational Level**



**Transition Management Clusters**

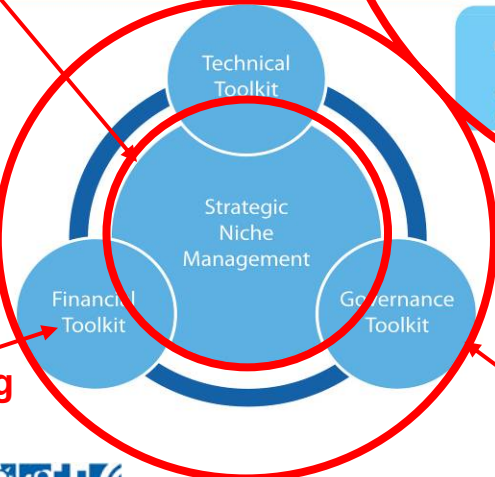

**Transitioning Tools**

**SWITCH Demonstration Projects**



## The Transition Framework

Section 2 describes the **SWITCH** Transition Framework and its different stages, levels, tools and methods. Section 2 describes how the framework works, what drives and manages change, and how the various components required for a transition fit together.

The urban water transition needed will change degraded, polluted or flooded environments into places of acceptable environmental quality and the framework assists that process.



Sewage pollution in Colombia



Runoff from mining in Venezuela



A SUDS pond in Vietnam



A community area and stormwater pond in Brazil

## The Transition Management Cycle

The Transition Management Cycle (TMC) lies at the heart of making changes in cities and its steps are detailed in Section 3 of this manual. The underlying principles of TMC are covered here.

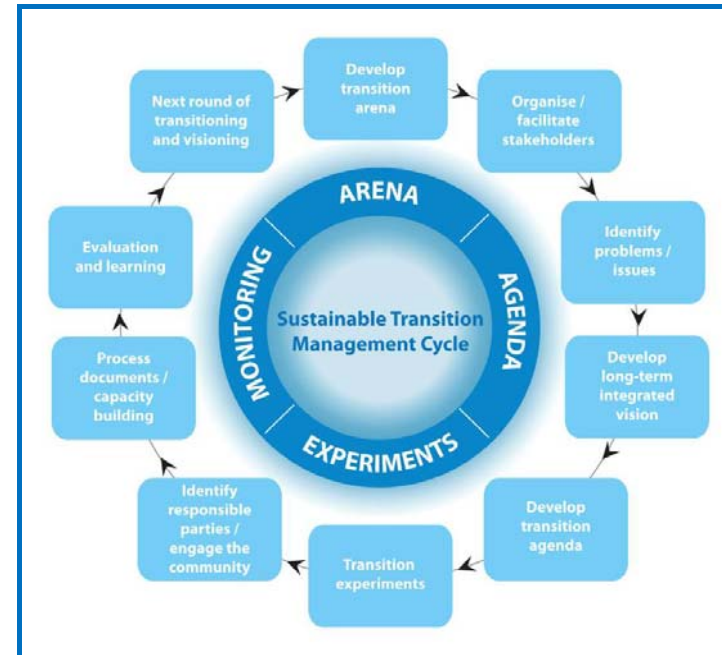

TM is a cyclical, coordinated, multi actor process operating on three levels - strategic, tactical and operational. The cycle is organised around four co-evolving activity clusters: Arena, Agenda, Experiments and Monitoring.

TM activities are aimed at influencing, organising, and coordinating processes at the different levels so that the processes are aligned and reinforce each other (Grin et. al. 2010).

## Transition Management Clusters



Transition Clusters provide a focus for the tools of the transition management cycle and they include:

- The **Transition Arena** (establishing the transition arena and problem structuring);
- **The Transition Agenda** (developing the strategic plan and sustainable pathways);
- **Transition Experiments** (initiating and implementing innovations); and
- **Monitoring**, evaluating and learning to close the loop and deliver the cyclical aspect of the process.

The transition management clusters are synonymous with the activities that have become known as the '**SWITCH** approach'. Transition clusters are explained in greater detail in section 3 of this manual.

### Transition Clusters compared to the SWITCH Learning Alliance Approach

Transition Clusters	SWITCH LA Approach
Establish the Transition Arena	Establish a Learning Alliance
Develop a Transition Agenda	Develop a Strategic Plan
Execute Transition Experiments	Carry out Demonstration Projects
Evaluate, Monitor and Learn	Monitor, Evaluate and Learn

## The SWITCH learning Alliances

The Learning Alliance (LA) is a grouping to bring new ideas, techniques and innovations into a city. The LA can operate at national, city and local levels, enabling it to view the essential components required to implement the transition. The LA provides the drive for innovations in the water system and has strong powers of influence in commissioning projects that demonstrate the implications of the transition being promoted.

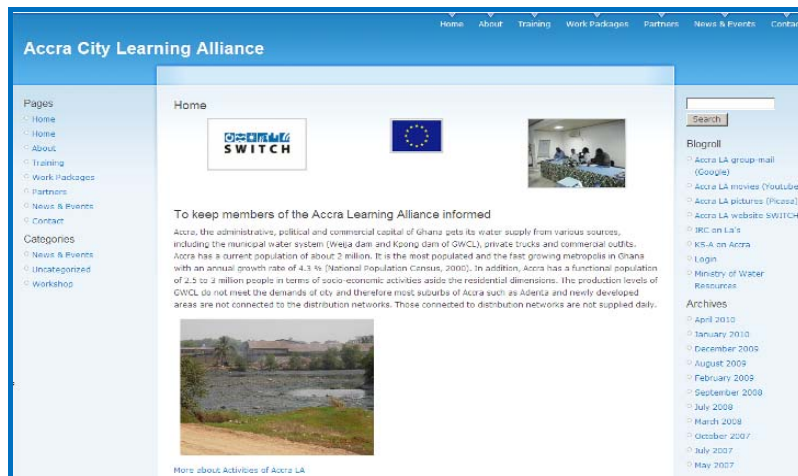

The Accra Learning Alliance website (<http://switchaccra.wordpress.com/>)

### Key points about Learning Alliances

- Learning Alliances create social capital and new networks, making it easier to find each other so you know who you need to talk to.
- Facilitation is important and translation between cultures and domains vital.
- 'UN style neutrality' can be an advantage, so platforms (of debate) are not politicised from start.
- Facilitation can be a trusted NGO, University, Municipality, which is ideally not implicated in local politics.

## Strategic Planning

Different perspectives such as cultural aspects, values, motives and perceptions must be considered when developing a strategic plan. Agreement on collective issues and goals will only be reached when there is agreement on the diverse perspectives for an integrated approach. It must be recognised that the issues are shared problems needing action. Problem structuring is crucial to developing policies and strategies to move a transition forward.

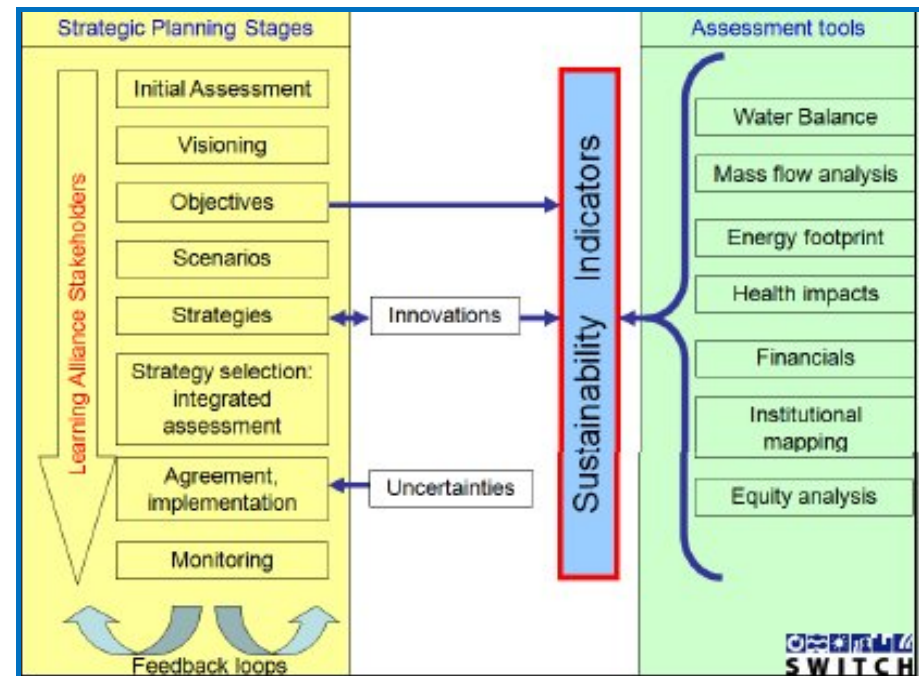

Assessing the sustainability of an intervention (Van der Steen and Howe 2009)

## Visioning

The vision for Sustainable Urban Water Management for a city must be exciting, and able to make people enthusiastic since visioning and scenario planning for sustainable pathways is an extremely important part of the transitioning process. It is the beginning of the journey and a significant amount of resources are required to ensure a good start to the journey.

Researchers at Monash University in Australia have developed a powerful visioning tool for use by stakeholders and actors in the transition arena at the strategic level. This tool is the conceptual Urban Water Management Transition Framework. (Brown, Keath & Wong 2009)

When planning for a sustainable future, stakeholders need to know where they want to arrive at in order to plan the pathway to get there. This framework provides a benchmark that shows stakeholders where their starting point is and where (potentially) they might take their city. The framework uses attributes that should ensure more sustainable city phases along the transition pathway. The framework enables all the stakeholders to visualise possible sustainable transition pathways or phases better. This includes the capacity development and cultural reform initiatives required to deliver the future paradigm of a 'water sensitive city' (Brown et al., 2008; Ison et al., 2009).

The first three phases described in the framework (water supply, seweraged and drained cities) identify attributes that are considered typical of the evolutionary changes within urban water management practices over the last 200 years in an Australian context.

The water supply city underpins the first type of formal 'hydro-social contract' that satisfied the need for a safe and secure water supply, usually through the construction of large water supply schemes and incorporating centralised infrastructure to supply water to expanding

populations. The seweraged city underpins the 'contract' to provide public health protection through delivery of sewerage services which direct waste flows to receiving watercourses. The drained city phase satisfies the need for flood protection through stormwater conveyance to watercourses in order to facilitate urban expansion.

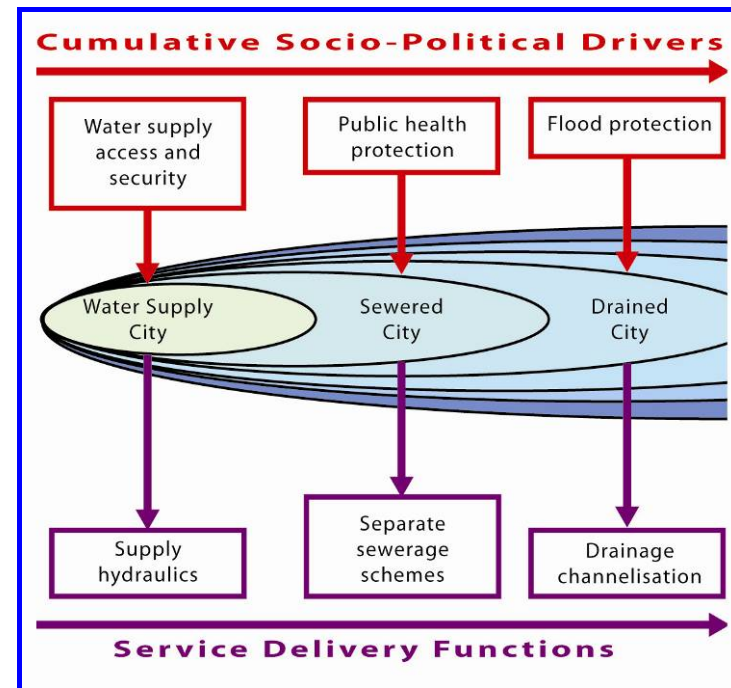

**First three phases of the Urban Water Management Transition Framework (based on Brown, Keath & Wong 2009)**

Attributes assigned to the waterways city are considered to be indicative of the current urban water management phase for many cities that are now moving towards more sustainable options. This 'contract' moves away from previous phases that did not consider environmental impacts. In a waterways city, water planning



## Section 2 – The Transition Framework Explained

becomes more important as the desire for visual and recreational features are embedded into service requirements. This results in the regulation and control of polluted discharges through innovative technologies to protect receiving water bodies.

Attributes assigned to the water cycle city are mainly academic and rhetorical; they reflect the need for social, economic and environmentally sustainable approaches that apply an integrated concept to management of the whole urban water cycle.

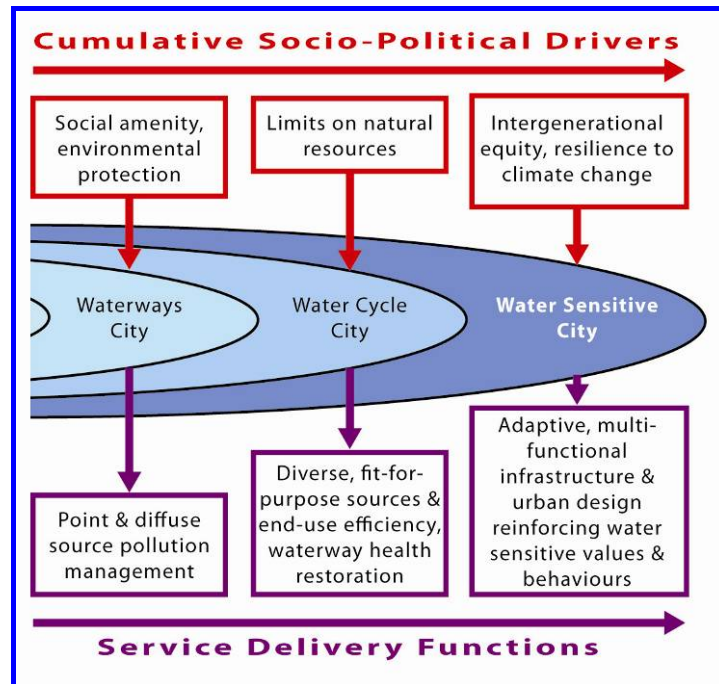

**Final three phases of the Urban Water Management Transition Framework (based on Brown, Keath & Wong 2009)**

Attributes assigned to the water sensitive city are based on contemporary futurist research that highlights that the 'hydro-social

contract' would be significantly different from that underpinning conventional urban water management approaches indicating that a major socio-technical overhaul is required. Technologies, infrastructure and urban landscapes would appreciate the links between society and technology resulting in engaged communities and practitioners that are supportive of sustainable lifestyles.

Many cities are shifting towards the waterways city model as they adopt urban water management practices offering more sustainable solutions, indicating that a transition take-off phase may be underway in some places. Water sensitive cities can not yet be found but some cities around the world are leading the way with approaches that resemble the water sensitive principles.

**Leapfrogging 'is the idea that there are new paths to higher standards of living which bypass the mistakes that other communities have made'.**

Corporate Social Responsibility (CSR) 2008

### The Leapfrogging Concept

The leapfrogging concept has primarily been applied to developing countries and newly developing cities. 'Leapfrogging' is the idea that developing cities could find new paths to growing their water infrastructure that are considerably more sustainable than those found in developed cities. The steps that have shaped cities in developed countries in the past represented in the first three phases of the transition framework may thus be avoided. By implementing new technologies and innovations, the mistakes and limitations of the slow route to water infrastructure might be

bypassed. This slow route has resulted in the existing cumbersome water infrastructure and all their associated problems, not least their inherent lack of sustainability in the long-term. Experimenting with innovations is the cornerstone of leapfrogging - not just identifying new technologies but finding new ways to apply existing ideas.

However, there is no reason why cities in developed nations should not to attempt to “leapfrog” also. Why should it not be possible to operate “parallel” systems? Infrastructure may be replaced by new generation systems once it had reached obsolescence instead of undertaking expensive conventional retrofit solutions. A current lack of infrastructure may actually be an advantage since there are no existing systems to fail with excessive maintenance costs.

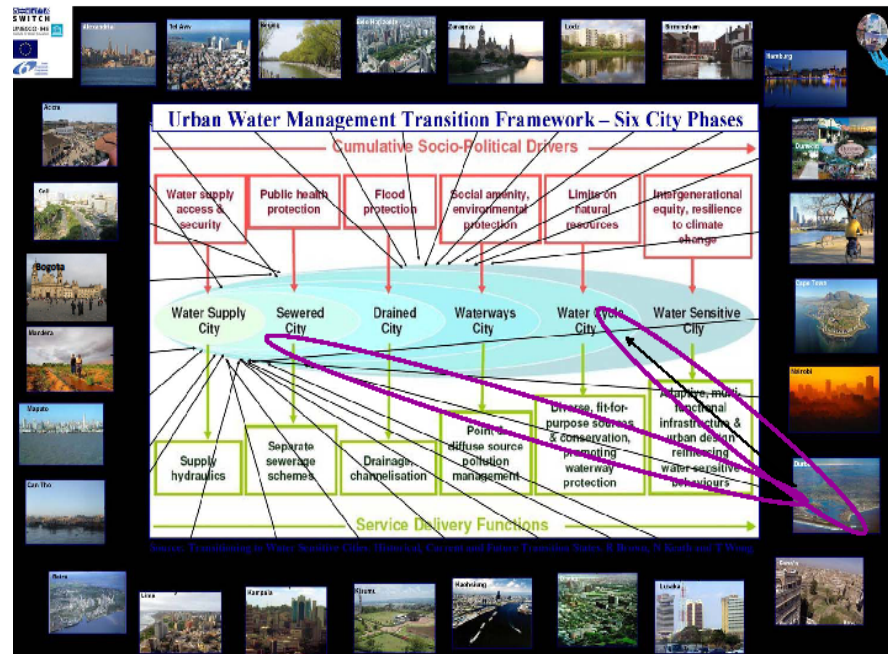

Leapfrogging traditional systems (framework adapted by C. Howe)

### Conventional Water System City

The urban water management transition framework provided a useful reference point for comparison of cities linked to **SWITCH**. The profiles of cities were placed within the framework depending on the service provision available. An example of the rationale behind this benchmarking follows: A city providing 80% water supply services but only 35% sanitation services and 50% drainage services could not be at the drained city phase. This city should be in between the water supply city and seweraged city phases.

However, developing cities are not now taking a linear approach since many already implement innovative and adaptive solutions that do not follow the paths of water supply, sanitation and drainage cities. In other words, many developing cities are ‘leapfrogging’ the conventional approach to water management through innovations to move their city towards a more sustainable paradigm.

### The SWITCH Approach

Based on a dialogue at the **SWITCH** City Water Summit in Delft in October 2009, the framework of Brown, Keath and Wong (2009) was adapted for **SWITCH** by using the Water Sensitive City as a central objective. Equal consideration is given to what is termed here ‘the conventional water systems city’ phase, which will always include provision of all water system services to varying degrees, and the Waterways and Water Cycle City phases.

In light of existing and future local and global pressures, it is probable that even developed cities will not follow linear paths for future cities as defined in the framework but will strive to incorporate attributes assigned to the waterways and water cycle city phases as they attempt to transition towards a water sensitive city phase. This approach also highlights the participatory and integrative activities required between stakeholders and activities to reach a sustainable goal for urban water systems.

## Section 2 – The Transition Framework Explained

### Strategic Niche Management

Strategic Niche Management is vital for the delivery of sustainable systems. A range of tools for transitioning have been used in SWITCH niche development in the cities through demonstration projects;

- Technical Tools for Transitioning
- Financial Tools; and
- Governance Tools



Innovations are vital for the delivery of sustainable systems since they provide the knowledge and experience, scope and pathways for a transition to occur. Since there are no hard and fast rules as to which innovations might be relevant to a particular city, they are termed niches and need to be nurtured and supported. New ideas need to be rolled out if transitions are to be successfully integrated into the city. These niches - technological and organisational - need to be encouraged in relatively protected environments by networks of dedicated actors supporting the new technologies who realise that the niche phase may be a long process.

Niche experiments should normally be aligned with the stakeholder led vision of the stakeholders since their funding and other support will be needed. Transition experiments may eventually see the innovation replacing current practices, thereby contributing to a sustainable transition.

Three mechanisms are used to manage transition experiments: **deepening** (learning as much as possible from a transition

experiment), **broadening** (repeating an experiment in a different context) and **scaling-up** (embedding an experiment in the existing infrastructure). SWITCH niche experiments in Ghana and Israel are illustrated below.

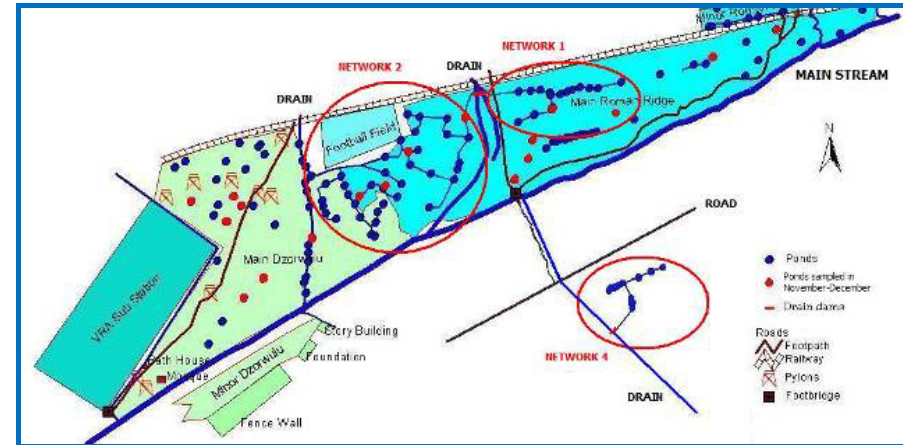

Potential test sites for on-farm treatment ponds in Accra, Ghana

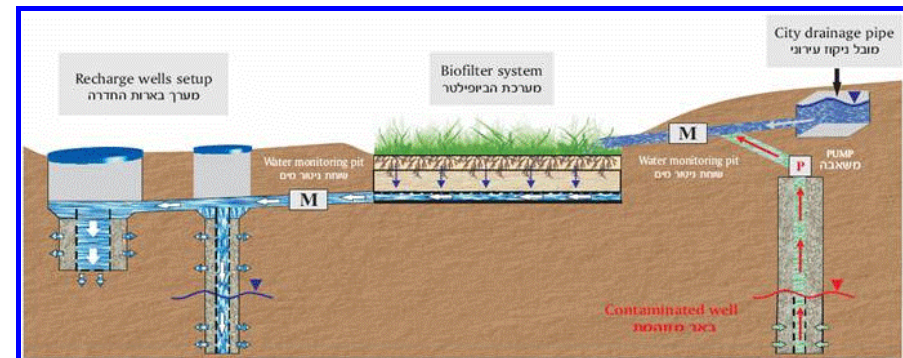

KFAR –SAVA Pilot Project, Israel demonstrating biofiltration of treated wastewater for recharge of aquifer

## SWITCH City Transitioning Stories

It is always good for the Learning Alliances to learn from the experiences of change in different cities so that new ideas and practices can be used locally.

Four cities – Accra in Ghana, Alexandria in Egypt, Łódź in Poland and Belo Horizonte in Brazil - are showcased in section five of this manual to see the progression in SWITCH and cast forward to suggest what transitions might occur in future.

It is clear that changes are occurring especially where the cities are developing, and the lives of citizens have been improved through the interventions in the water sector.

## Tools used in Transitioning

Many different types of tools can be used to assist in the transitioning process, ranging from technical analysis through city planning to financial evaluation and processes for improving the governance of marginalised industries.

Tools are used to evaluate current conditions in the water supply or drainage networks to determine how they might change when a transition in a city occurs. They enable evaluations to be made of the current situation and the possible options for a transition trajectory.

One particular issue when using tools to evaluate potential transitions is the timescale involved. Many of the tools in day to day use for the development of solutions to water problems are of little value for developing integrated solutions. This is because, in general, design and analysis tools used to solve today's problems are very detailed. They do not lend themselves to the holistic approach required in integrated urban water management where a drainage issue may impact on a water resources problem, which

may in turn reduce the amount of irrigation water available at a third location.

Tools supporting transitioning permit different and broader options to be identified and evaluated, thus helping inform decision makers better. The changes needed are not only about new components or techniques. For example, better means of communication are often just as important as calculating further details of the impact of a process on a system.

Most of the tools included in section 6 of this manual primarily, but not exclusively, consist of **SWITCH** research outputs from niche development within the cities.

The principal decision making tools developed in **SWITCH** include City Water Information System (CWIS), City Water Balance (CWB) and City Water Economics (CWE). All these tools assist with planning and choosing future directions for a city.

In the **SWITCH** approach, the water management issues that require to be addressed are identified through the **Learning Alliance**, which decides which ideas and niches require study and investment. The niche might be the provision of better surface water management, or fitting devices for using scarce water more wisely, or even improved communication with customers. Strategic niche management is vital for the delivery of sustainable systems by bringing in the different tools and technological innovations that are vital for systems delivery since they provide the knowledge, experience and pathways for a transition to occur.

Ten tools for transitioning are included in section 6 of this manual.

## *Section 3*

# *The Transition Management Cycle*

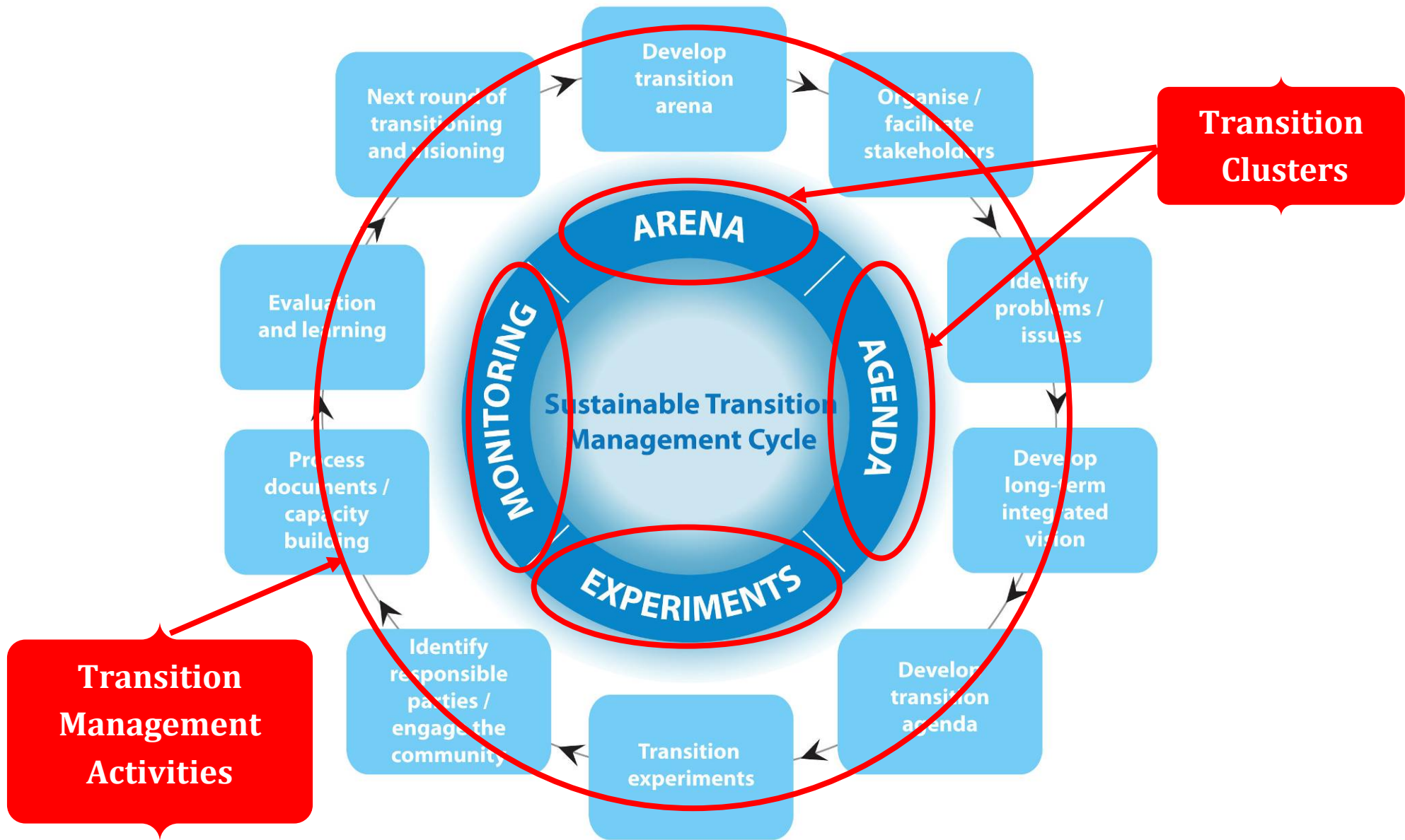

## The Transition Management Cycle

This section details the different component parts of the Transition Management (TM) Cycle. As adapted for **SWITCH**, there are ten TM activities grouped into four Transition Clusters.

There are ten separate activities in the transition management cycle and each is described later in this section. The activities are;

- Develop the transition arena
- Organise and facilitate the stakeholders
- Identify problems/ Issues
- Develop long term integrated vision
- Develop the transition agenda
- Transition experiments
- Identify responsible parties and engage the community
- Process documentation and capacity building
- Evaluation and learning.
- Next round of transitioning and visioning

## Transition Management Clusters

Transition Clusters are synonymous with the activities that have become known as the ‘SWITCH approach’ or the ‘SWITCH intervention’.

Transition Clusters are the systemic instruments of the transition management cycle. As with the Transition Management Cycle, the clusters form a closed loop to deliver the cyclical aspect of the process. Each circuit of the cycle has to be evaluated and progress adapted in a clear way for any development process.



Transition Clusters (after Loorbach and Rotmans 2006)

### Transition Clusters compared to SWITCH Learning Alliance Activities

Transition Clusters	SWITCH LA Intervention
Establish the Transition Arena	Establish a Learning Alliance
Develop a Transition Agenda	Develop a Strategic Plan
Execute Transition Experiments	Execute Demonstration Projects
Evaluate, Monitor and Learn	Monitor, Evaluate and Learn

## The ARENA

### Establishing the transition arena and problem structuring

The transition arena is a 'protected space' (Loorbach 2007) where alternative visions, agendas and actions can be developed. The transition arena should interact with general water policies so that, as innovations mature, future policies may be influenced. The involvement of diverse actors is a deliberate 'network' strategy that is based on the recognition of conflict of interests where confrontations will arise. This leads to 'second order' or social learning where the actors reflect on their own practices and roles within the bigger picture. Within the transition arena, individual actors, such as expert, communicator or networker, often play different roles.

For the promotion of sustainable solutions that deliver integrated urban water management practices an improvement in governance is required in both mechanisms and processes and in structures and institutions. The aim of **SWITCH** interventions is to work with stakeholders by facilitating the Learning Alliance transition arena allowing stakeholders initially to identify unsustainable urban water management practices in their city. They were then encouraged to move forward, and 'do better' than in the past by choosing and implementing more sustainable solutions through exchange of knowledge between cities, scientists and stakeholders. Learning alliances that have a broad membership including marginalised stakeholders will have more scope to engage with governance issues and deliver a more integrated and sustainable vision.

Social learning is about individuals, groups or organisations questioning and reflecting on the values, assumptions and policies that drive their actions and change them. This form of learning about uncertainty and complexity is an important part of society steering processes because uncertainty and the increasing complexity of governance processes are often structural in nature. Social learning is all about developing interaction with others who

might have alternative perspectives. It is important to gain insight into the perceptions of others who are learning at the same time because it is only when we understand other's ideas, motives and visions that we will be able to search together and develop a common agenda. Through creating stimulating contexts such as developing future scenarios and facilitating the exchange of information and knowledge, social learning can be stimulated (Loorbach 2007).



**LA meeting in Alexandria**

Key outcomes of setting up a good arena are a new shared perspective, a language to discuss the transition, and the definition of a set of guiding principles for the transition envisioned. Activities carried out by the Learning Alliance (see page 37) at this stage include visioning and scenario planning that result in a future vision of the urban water management practices for the city. Becoming aware of and having insight into the complexity of their current situation helps individuals better understand the complexity and the possibilities for them to influence systems.



## Section 3 – The Transition Management Cycle

### The ARENA

#### Forming The Learning Alliance

An integrated analysis of systems forms the basis of every transition management process as it provides a common ground and enough information for a variety of stakeholders to have debates and discussions. Informed insight should be provided into;

- The complexity of the system;
- Its major defining subsystems;
- The dominant causal relations;
- Feed-back loops.

The nature of structural problems establish a baseline for moving forward. Conditions for discussing visions, strategies and actions in the future are formed in parallel. This preliminary assessment will provide knowledge about the main actors who influence the system both in an innovative and informed way. Furthermore, the assessment helps to guide the selection of participants for the LA.

Selection of Learning Alliance participants is of vital importance for several reasons:

- Participants need to have appropriate competencies to bring to the table.
- They need to be open-minded leaders, who have vision and the ability to look beyond their working area.
- They must function autonomously within their organisation but also have the ability to convey the vision developed and develop it further within their organisation.

As the process progresses, the transition arena will expand slowly, involving new actors while at the same time some participants may leave the transition arena after their contribution has been made.

#### Visioning Methodology

- Step 1: Form LA or stakeholder platform
- Step 2: Agree on the scope of the vision
- Step 3: Review existing visions
- Step 4: Identify main issue
- Step 5: Develop an outline vision
- Step 6: Check for consistency with other visions.
- Step 7: Assess probability of achieving the vision
- Step 8: Wider consultation.

From SWITCH LA Briefing Note 9: Visioning. (Batchelor & Butterworth 2008)

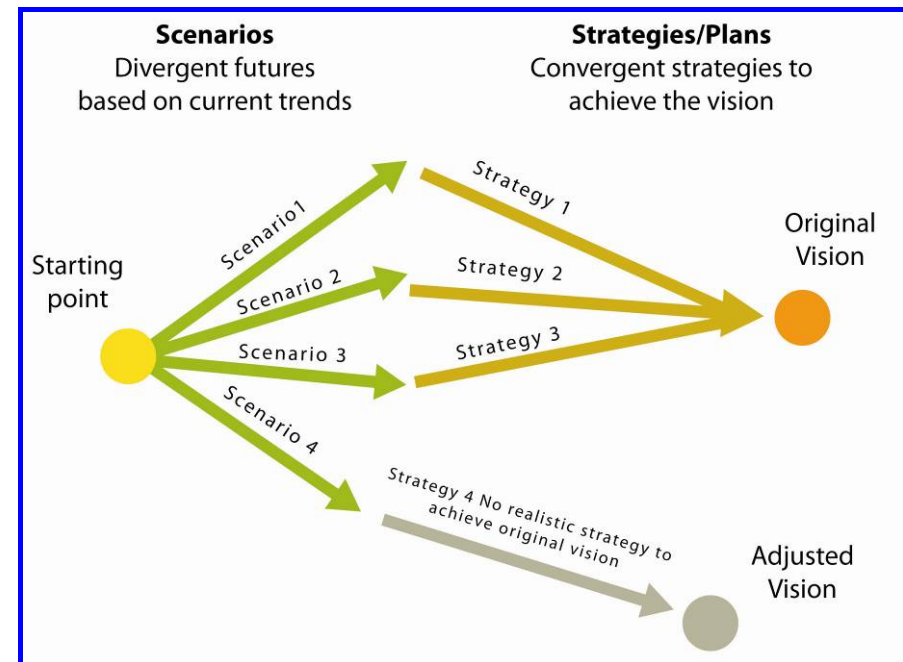

SWITCH Strategy for IUWM (from EMPOWERS Project  
(<http://www.project.empowers.info/page/121>))

## The AGENDA

### Developing the transition agenda, strategic plan and sustainable pathways

Developing the transition agenda is more important than the actual agenda itself since barriers are identified and pathways, issues to be changed, and sub-strategies are mapped out. The process of building the transition management agenda is similar to political agenda setting in that it constructs, negotiates and debates to deliver an evolving agenda where new issues take over from old ones. Transition management focuses on agenda building at the level of societal systems and infrastructure networks. (Grin et. al. (2010)

Key concepts of transition agenda building are problem recognition and structuring, and the balance between individual and collective agendas. Recognising barriers to deliver a transition in all domains assists with collective visioning.



LA decision making process in Łódź

As with transition management, a systems analysis approach is fundamental to **SWITCH**. Key areas of detail, or sub-systems should be identified where this approach could be expanded to take

sustainability into account. **SWITCH Learning Alliances** and their drive for demand-driven science, combined with strategic planning mechanisms that have long-term objectives show how multi-disciplinary and integrated approaches may influence and potentially accelerate sustainable trajectories for new generation urban water systems that can cope with global challenges (van der Steen and Howe 2009).

#### Establishing the SWITCH Learning Alliance in Beijing

##### Data

- Population (about 18 million in 2009)
- Land area (16800 sq.km.)
- Rainfall changes (600-400 mm yearly)
- Greater Beijing Regional water resources inventory

##### Water management analysis

- Share of water uses between sectors: 50% for agricultural use
- Water use in urban areas is increasing rapidly
- Pricing increase in water use enhance efficiency
- Stakeholder analysis

##### Learning Alliance establishment

- Up to 15 stakeholders involved regularly as LA
- Up to 6 stakeholders formed as a working group
- Up to 4 formal and many more informal meetings

### EXPERIMENTS

#### Initiating and carrying out transition experiments

Experimentation is essential for bringing forward and developing new ideas. Economic development through dynamic competition between optimisation and innovation is the alternative to stagnation. The destabilising force of innovation is often termed 'creative destruction' (Loorbach 2007). The message here is clear; the possibilities for innovations depend on where they are occurring, and the changes over time. This is why continuous reflection on a city's societal and cultural environment is important to ensure that innovations chosen can reach maturity and be scaled-up.

Transition management considers societal innovations, which are driven by both ecological and large-scale institutional and cultural innovation, and attempts to influence the diversity of options and subsequent selection. Transition management also focuses on socio-technical innovations where technology development integration, and diffusion of the knowledge are facilitated.

#### Up-scaling of the Rainwater Harvesting Project in Beijing

- More RWH projects have already been implemented in Beijing
- Some training on RWH for peri-urban agriculture in Beijing is planned jointly with local government
- The municipal government has decided that a modified RWH methodology based on the SWITCH demo project will be promoted in the coming years.



#### Combined detention basin and creek restoration, Belo Horizonte

The sustainable and integrated vision developed through the arena and agenda will set in motion a number of actions, new ideas and activities required to meet that vision. Niche experiments undertaken will be aligned to the vision developed by the Learning Alliance. The transition experiments in the niches may eventually see the resultant innovation replacing dominant practices, and contribute to a sustainable transition.

## Monitoring, evaluating and learning

Reflection and social learning is the final aspect of transition management. Social learning is important because, while a range of technical and financial tools are available, they must be accepted and embraced by the local society if they are to be of value. This ensures that the stakeholders will cope better with uncertainties, emerging developments and surprises since there is strategic interaction amongst the actors.

Anticipation of future transition dynamics helps develop flexible, forward-looking strategies. Systematically evaluating progress in steps or stages helps the actors in the transitioning process adapt to changes in the environment and possible consequences of the transition management process itself. A stepwise approach has four main advantages (Loorbach 2007):

- Each step should be achievable because it is not disruptive;
- Costs are kept low in case a mistake is made and needs to be rectified;
- The trajectory (of the change) can change course and not get 'locked-in' to a particular solution;
- Useful lessons can be learned that may inform future steps.

However, an incremental approach to transition management is not the only answer. This is because, when attempting to change societal systems that have persistent problems, there are too many variables. Two examples are:

- The many 'right directions' that will be taken in small steps, and;
- Different goals chosen that test different solutions to achieve the goal, which, in turn, may need to be redefined.

Innovations are not born but require to be adapted before they can be defined as a good solution. Evolutionary change that is based on trial and error, variation and selection is often an intelligent approach in the long run but wasteful in the short term. This view

has greatly influenced transition management which proposes concrete strategies to develop long-term visions and intermediate goals to inform incremental action (Loorbach 2007).

Periodic review ensures that the desired direction continues to reflect changing circumstances and the appraisal of new interventions. The debate is re-opened as to what is the most sustainable future path for a city – why is it sustainable? for whom is it to be delivered? and how will it be done? This allows plans to be adapted or activities within an already developed transition vision to be adjusted.

### Monitoring and evaluation objectives

- Know who LA members are and how to communicate with them effectively
- Multi-stakeholder engagement is based upon sound research and analysis
- The LA action plan/ city storyline should be regularly reviewed and updated
- Regular, effective and innovative events capture interest of LA members
- Ensure regular, quality flows of information between LA members
- Stakeholders are involved in priority setting in research
- Demonstration activities are undertaken within a framework for scaling-up
- Understand why IUWM change is occurring, not just what happens
- Issues of social inclusion (gender, poverty, and other marginalised groups) should be systematically mainstreamed across all project activities in the city.
- The LA should contribute to empowerment of marginalised groups
- Resources (in-kind and cash) are levered as a result of working in partnerships

From SWITCH LA Briefing Note 7: Monitoring and evaluation of project outcomes. Butterworth and da Silva (2007)

## Transition Management Activities

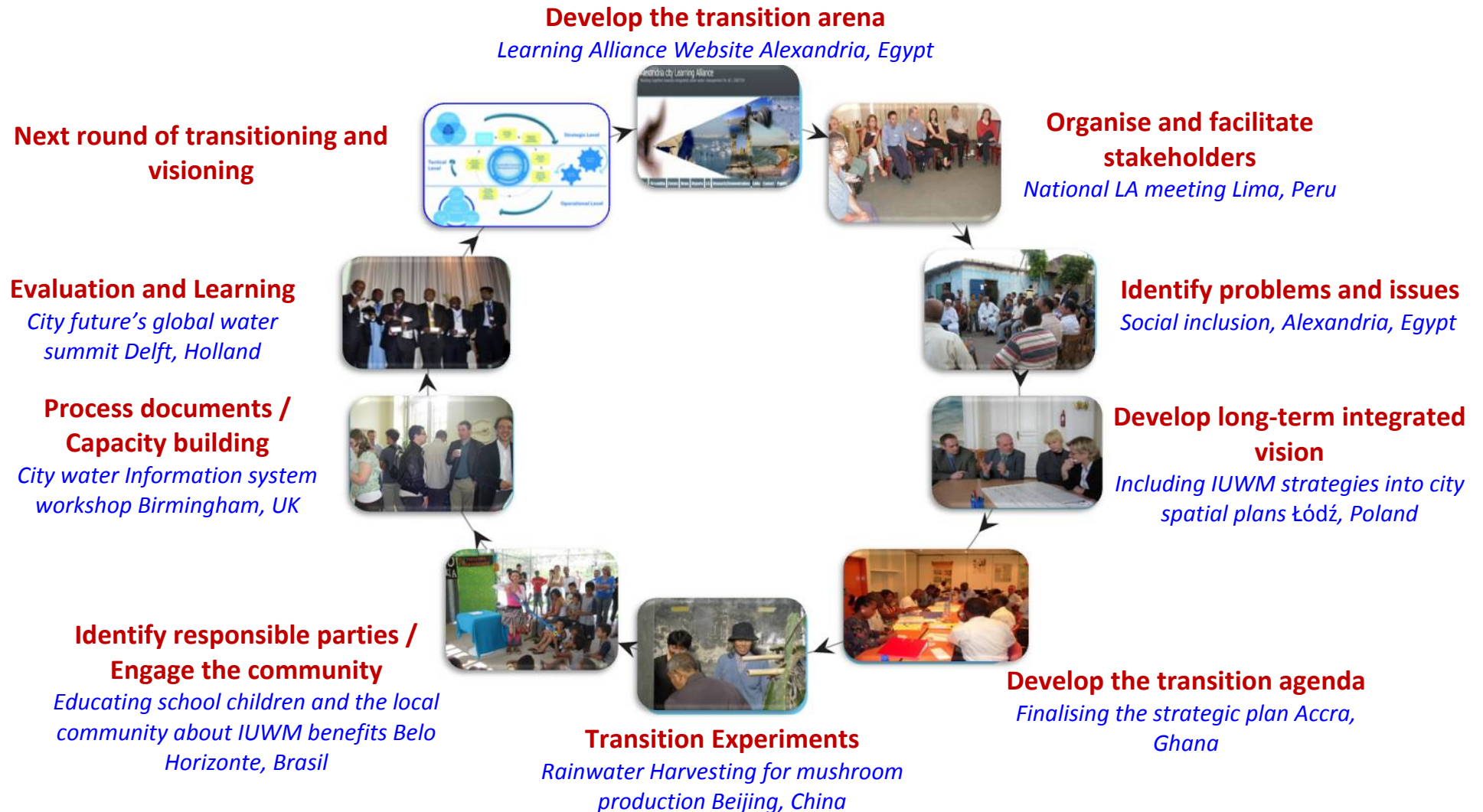

## Develop the Transition Arena:

### Organise permanent innovation and support

Activities in the transition arena are multi stakeholder led actions with representatives who come from government, non-governmental organisations, businesses, universities and colleges and the voluntary sector. Transition management influences and manages existing networks and actors with a combination of internal and external steering groups.

The arena is the place where ideas for the transition are developed. To do this, well informed and suitably trained individuals need to have a good forum to work together to enable good communication. The right people from the right organisations need to be found to join the arena.

A budget is required for groups to work effectively together. This is not just for the studies, experimentation and scaling up of new ideas, but also for the more mundane tasks such as record keeping. Processes must be documented to ensure that lessons are best learned. The activities of the LA should need to be publicised particularly to engage with influential stakeholders outside the alliance.

The most appropriate experiments and demonstration projects need to be identified, particularly those which can be scaled up.

Participation in the Learning Alliance promotes and generates public support. This is an important advantage, since social inclusion enhances the legitimacy of decision making and helps to reduce the risk of disagreement between stakeholders. Good participation of key stakeholders also provides additional sources of knowledge, ideas and information when learning about problems and solutions. The involvement of all stakeholders ensures that the

particular needs of organisations and individuals where necessary are defended, and negotiations on different goals for the water system are possible (Loorbach 2007).

#### Key stakeholder types in SWITCH

- Key organisations responsible for water management in each city. These include organisations who make decisions or effect changes in policy and practice (policy analysts and advisors, policy makers, municipal/local government personnel (political and bureaucratic), service providers (public, private and voluntary, regulatory authorities etc);
- People with influence among decision-makers directly (members of parliament, private sector companies);
- Civil society organisations and individuals who can bring pressure to bear on decision-makers (e.g. NGOs, unions, professional associations etc);
- Water user groups (e.g. consumer groups, irrigation groups);
- Local 'leading lights' (activists or champions) working to address poverty, gender equality, environmental issues)
- Those who can support, reinforce and strengthen SWITCH's activities and recommendations (training and research organisations, financial organisations);
- Those in the media who provide a means by which the learning alliance can reach the public; and
- The donor community, who can further finance and support SWITCH's activities.

From SWITCH LA Briefing Note 2, Stakeholder Analysis. Verhagen (2007)

## Section 3 – The Transition Management Cycle

### Organise/ Facilitate stakeholders:

#### Creating room for innovation and governance

Problems must be defined for the stakeholders through the process of working together and understanding each others' long-term ambitions and aspirations. Everyone needs to be able to see where the transition might be of help for each participant even if it might take a long time. At the same time, innovation and competition between ideas, options and agendas must also be possible in the short-term. Insights from the experiments and studies are used to create paths for change while also making sure that poor ideas are not accepted unnecessarily, for example through good selling of an unsustainable system.



Academic advising leather factory owner in Bogotá, Colombia

In the **SWITCH** project in Bogota, the main stakeholders were the owners of a group of leather factories. They needed an arena in which the severe stream pollution they were causing in the local river could be addressed. **SWITCH** provided a facilitator who advised them in their negotiations with the environment agency and other governmental organisations. The problem was relatively easy to define – how could the companies stay in business AND address

the pollution at the same time. A common plan – ‘the room for innovation’ - was drawn up through the stakeholders working together (normally they are in competition) and this was agreed with the relevant agencies. The innovation in this case was to have a common approach and a common facility for handling waste material.

The purpose of the **SWITCH** demonstration project in Beijing was to show that water could be harvested for use in small farms in an economic way. Beijing is in a water-scarce region and the main attraction for stakeholders (local farmers) in the demonstration project was more effective rainwater harvesting (RWH) designs that would be viable and financially cost effective. For a project of this nature, the benefits to be gained from RWH should be clearly shown in demonstrations to the stakeholder farmers. They must be able to see the results of the experiments. In the project, a new system was set up and the best designs were demonstrated.



Stakeholders in the RWH Project in Beijing, China

## Identify Problems and Issues:

### Getting to the Real Point

This phase is likely to require a significant number of investigations about the problems and issues causing the water system in a city to perform below standard. Without such studies and subsequent analysis, the problem cannot be properly quantified and solutions will not be found, or they may be quite inappropriate.

In addition to lack of data, the local physical and human geography may prevent identification of issues pushing less sustainable solutions. The key factors influencing problems and the interests of those most affected must be determined. The influences on decision making must be determined, together with the governance and regulatory issues influencing the problem.

Once the transition cycle has started, the key issues, and the factors influencing them, must be re-evaluated. This is achieved by analysing the changes that were attempted and were successful, comparing the results with those that were unsuccessful. The reasons why the proposed change was adopted or rejected within a given governance subsystem are key to understanding success and failure.



**What causes the flooding problem in Belo Horizonte? - the small channel on the left, or the favela on the right?**

## Develop the Long Term Integrated Vision:

### Finding the right future for everyone

Transition management does not aim to control the future; it attempts to influence ongoing processes of changes in society by systematically reflecting on the future and developing shared notions for desired sustainable futures. Transition management anticipates long-term effects and influences through the use of visioning, scenario and trend analysis, and selection of appropriate innovations. The joint vision is not set in stone but should act as a framework for action, which can be modified as time progresses. The future will always be uncertain but systematic reflection of what is likely to occur will ensure that flexible and robust strategies can be developed (Loorbach D. 2007, Butterworth, J., Dasilva, C., 2007)

#### Notes on visioning

- Visions are invariably political. Facilitation is needed to reconcile often very different views on the relative importance of, for example, environmental sustainability, economic growth and provision of water services to poorer social groups in a vision.
- It is often easier to get consensus amongst a diverse group of stakeholders on the components of vision than it is on the strategies and plans for achieving a vision.
- Visioning gives stakeholders an opportunity to discuss their concerns and fears with other stakeholders and/or members of an LA.

From LA Briefing Note 9: Visioning; Batchelor and Butterworth (2008)

Anticipation of future trends and modifications to strategies and visions is important when developing a future vision and when reflecting on the progress of a transition. Having a good and flexible plan for the years ahead is the key to a long-term strategy.

Future orientation should be accompanied by adaptive strategies meaning that vision and transition end goals should be adjusted as the structure of the system(s) being implemented changes.



## Develop the Transition Agenda:

### Innovative, Ambitious and Evolving

Flexible and adaptive approaches to transitions are developed through shared agendas by having a range of experiments that stimulate innovations, which might be technological, institutional or socio-economic. These approaches must be constantly questioned and re-evaluated to encourage a combination of ‘push and control’ strategies with those of ‘pull and adapt’ depending on where power lies.

This reduces the problem of unforeseen side effects of the strategies or innovations chosen. Ambitions, goals and strategies should be constantly re-assessed together with the policies which are designed to achieve progress (Loorbach 2007).

#### SWITCH Paradigm shifts

- Switching emphasis from researchers devising new technologies
- Doing different things: to improve how the multiple stakeholders in the innovation system work, doing things differently, will lead to interventions having greater impact
- Innovations that are generated locally, taking all the relevant stakeholders into account, are more likely to lead to appropriate and sustainable solutions, to promote flexible and adaptive working practices, and to foster and strengthen the development capacity of local organisations and communities
- New understanding of knowledge and learning, and the emergence of learning organizations: whereas information can be generated and disseminated, knowledge is viewed as a complex, transformative process, arising less from any accumulated stock of information, and more from intra- and inter-organizational processes in which experimentation (action research) and communication feature strongly.

From SWITCH LA Briefing Note 3: Thinking on Learning Alliances da Silva Wells (2007)

Visions guide the transition process but transitions also shape the visions developed as societal goals and ambitions evolve through new insights knowledge and the experience derived from short-term experiments. Experience and ambition are as important as visioning for informing the next steps in the transitioning process.

#### Using the press to assist the Agenda in Zaragoza

A new system to reduce the cost of water

The Actur neighbourhood has been chosen by the council town to start a pilot project, which tries to reduce the drinking water losses in the buildings and in the watering systems of the zones with gardens.

The infrastructures that allow water supply comes from the same point and makes the control of water expense easier will be organized. The network will be monitored with water meters and other technical devices to know any water loss and financial department will collaborate and through the receipts will evaluate the functioning of the communities. Also, watering of green areas will be taken into account to know how much water is used.

The project will last 60 months, during which data will be gathered and measurements of water saving will be developed. Moreover, an exact radiography will be carried out to improve the efficiency of the water distribution system with measurements as the division of the network in sectors to be able to detect the water losses.

The installation of water saving devices was at the top of the transition agenda in the city of Zaragoza in Spain at the end of 2006. Lola Campos, councillor for the Environment in Zaragoza brought political leadership to the action which “..involves joining the efforts of several municipal departments and it also implies the collaboration of neighbours”.

“We would also like to try to connect the ten cities of Switch and to come to an agreement between all, in a protocol of Zaragoza.. and we want it to be similar the Kyoto protocol. (on climate change).”

Quote from Lola Campos in the Aragon Digital Newspaper

20 MINUTOS 29/11/2006

### Un nuevo sistema para reducir el gasto de agua

**El Actur ha sido el barrio elegido por el Ayuntamiento para poner en marcha un proyecto piloto que pretende reducir las pérdidas de agua potable en inmuebles y en los sistemas de riego de zonas ajardinadas.**

Se organizarán las infraestructuras para que el abastecimiento llegue desde un mismo punto y sea más fácil el control del gasto de agua. La red se monitorizará con contadores y otros dispositivos técnicos para conocer cualquier fuga y tendrá la colaboración de Ha-

cienda que, a través de los recibos, evaluará el funcionamiento de las comunidades. También se atenderá el riego de zonas verdes para contabilizar toda el agua que se gasta.

El proyecto durará 60 meses, durante los cuales se tomarán los datos y medidas de ahorro y se hará una radiografía exacta para mejorar la eficiencia del sistema de distribución con medidas como la división de la red por sectores, de forma que se puedan detectar las pérdidas.

## Transition Experiments:

### Keeping Options Open, Finding New Ways

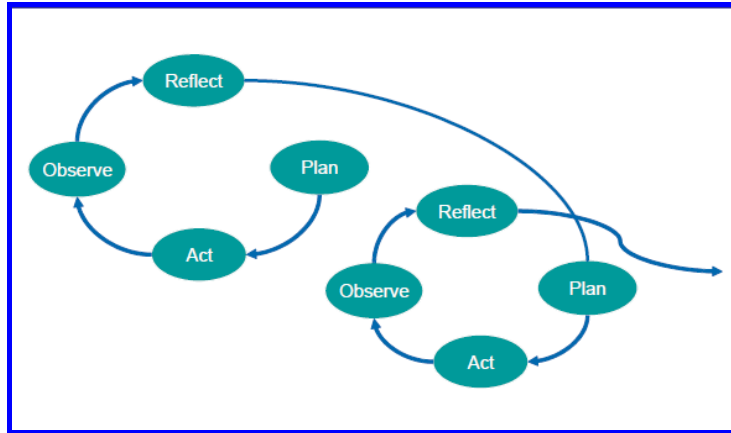

From SWITCH LA Briefing Note 3: A brief introduction to action research concepts and practice. Moriarty P.

Experiments come in all shapes and sizes and by their very nature, they open doors on new options. However, there is no guarantee of success so three mechanisms are used to manage transition experiments (Grin et. al. 2010):

- Deepening - learning as much as possible from a transition experiment,
- Broadening - repeating an experiment in an adjusted form in a different context, and
- Scaling-up and embedding an experiment in the existing structures of the current system(s) of water management.

One of the experiments in the **SWITCH** project in Belo Horizonte, Brazil was to model the economic consequences of floods. The model focused on households and their economic relations within the city - consumption, workplace etc. Seven researchers and three institutions in Belo Horizonte collaborated with SWITCH on

this project in which a particular focus was scaling up from the study sites into 74 regions.

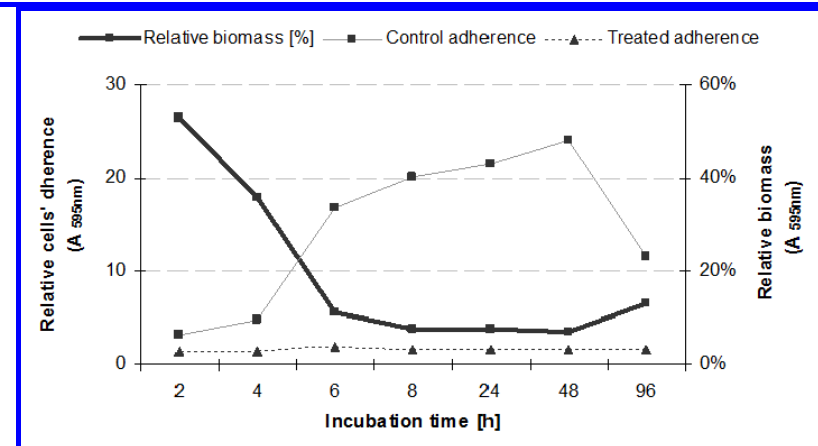
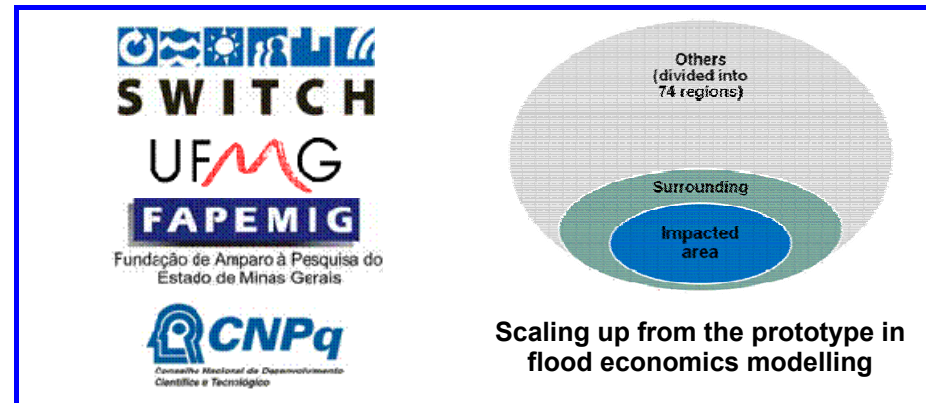

### Relative biomass formed by control and treated bacterial cells

The above graph is typical of the results from carrying out transition experiments, in this case for using new sources of water. The graph was shown in a presentation titled '**Biofouling Control in UF membrane Systems Using Silver Nanoparticles**'. The study was carried out by four researchers at the Hebrew University of Jerusalem and Tel Aviv University, Israel.

## Identify Responsible Parties:

### Who has the Power to Make a Change?

Historical analysis of successful transitions gives insights to the type of champions who have a significant impact on the dynamics of transition pathways. It is usually innovative individuals and not institutions that have a positive impact on transitioning activities both at the detailed and at a strategic level. These champions are generally powerful actors with strategic capabilities in the business sector, the policy domain, academia or society.

#### Influencing decision makers for SUDS in Scotland

In the late 1990s, the Scottish Environment Protection Agency looked for a key player who could assist in the introduction of new approaches to drainage. They brought in an eminent consultant and academic from the United States who had the stature and knowledge to 'bang heads together'.

Such an authoritative person was able to attract the key players from all stakeholder groupings while at the same time producing a unity of purpose.

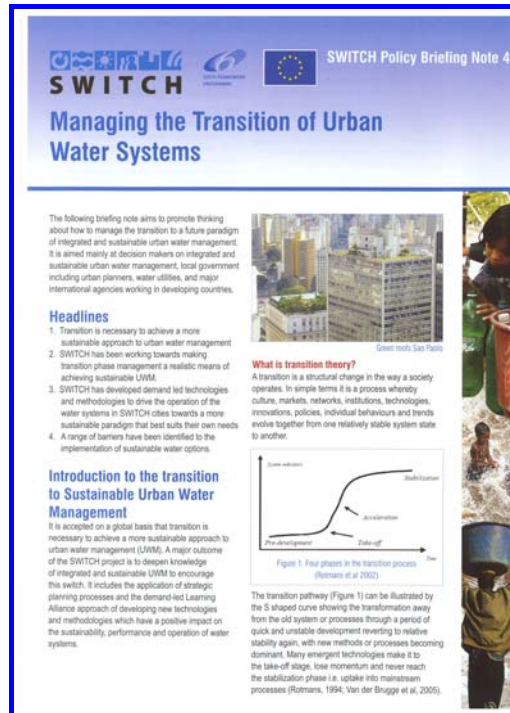

Briefing note for policy makers

## Process Documentation and Capacity Building:

### Attention to detail

Process documentation captures systematically what happens in a process of change and how it happened. Good process documentation enables the stakeholders to reflect and analyse why changes happened and to organise and disseminate the findings.

#### Principles of Process Documentation

- Go to the stakeholders, discover their perspectives and give them a voice by interviewing them and taking photographs, video etc.
- Go to the events where project objectives meet the traditional beliefs, relationships and attitudes in water management and observe the tensions and conflicts.
- Study and describe the context – read articles and books and talk to wise people (professors, teachers, older people, mayors, traditional leaders etc.).
- Organise moments, systems and ways in the project to step back far enough from daily project business to reflect and analyse on trends and patterns.
- Disseminate your findings, reflections, interviews and photographs. Share them and use them to stimulate debate.

From SWITCH LA Briefing Note 6: Process Documentation. Shouten (2007)

This is particularly important after different project phases.

#### Commitment to the SWITCH website after April 2011

The ongoing SWITCH website will include

- Revised homepage reflecting end of the project
- Database of freely downloadable Resources provided by end of project
- Links, e.g. to Training Desk, city websites, all consortium members
- Website / links will be maintained, but no new material will be added

## Evaluation and Learning:

### Learning from Past Successes and Failures

The next steps should only be taken after there has been a systematic analysis of the previous transition management cycle. It should be thought of as an approach where investigation and learning take place at the same time. The process is made up of (Grin et. al. 2010);

- Learning to learn,
- Doing-by-learning - developing empirical knowledge and testing it against the theory, and;
- Learning-by-doing - developing theoretical knowledge and testing it through practical experience.

Social learning is central to the transition processes because it focuses on re-framing and changing the perspective of the players. It also creates variation in terms of multiple pathways and experiments.

**SWITCH** Policy Briefing Note 1  
**Acting Together for Better Water Management in Cities**

"It takes sometimes to get abstracted by all the shiny technology and patent-saving goodness that comes with ecoties and forget about the people part"  
(Mark Achbar, 2008)

The following briefing note contends that acting together in cities will be at the heart of achieving any substantial system change or paradigms shift towards more sustainable or more integrated urban water management. It is aimed mainly at decision-makers on integrated and sustainable urban water management, local government including urban planners, water utilities, and major international agencies working in developing countries.

**Headline facts**

1. Social and institutional issues, rather than technical issues, are the key to sustainable urban water management
2. A learning alliance is a group of organisations from a given system that seeks to effect widespread impact through the adaptation and up-scaling of an innovative approach
3. SWITCH is successfully engaging users of research, with potentially high impacts, and ensuring that research is getting into water use
4. Multi-stakeholder research processes are challenging and expensive, and the costs of promoting change are frequently underestimated.

**Introduction: Urban water governance**  
Urban water management typically involves and impacts on a long list of stakeholders. These include organisations who effect changes in policy and practice; service providers; people who influence decision-makers; civil society organisations who can bring pressure to bear on decision-makers; water user groups; activists working to address poverty, gender, environmental issues etc; training and research organisations; the media; and donors and financial organisations (Shaw, 2008).

**Box 1. What do we mean by governance?**  
Governance is not synonymous with government. Rather, it is about how governments, institutions and social organisations interact with citizens when making decisions and implementing them. It is the process of decision-making which determines how decisions are taken and who has the power, and in what capacity, to make decisions. It is also about who is held accountable for these decisions.  
(John Shaw et al., 2009)

This contributes to the complexity of urban water management and makes it difficult to influence, adapt, or improve the situation. It is argued that social and institutional issues are actually the key to sustainable urban water management more than technical issues. (Shaw and Famley 2009) believe the focus therefore to be on 'transparency, resources, responsibility, knowledge, vision, commitment and coordination' in any programme of change.

In response to these challenges, and the difficulties of transitioning to a better approach, SWITCH has sought to understand governance issues and to support cities to develop stakeholder patterns known as learning alliances (LAs).

## Next Round of Transitioning and Visioning:

### Reorientation and Restructuring

The transition management cycle is almost complete by this stage, but the journey towards a sustainable and integrated water infrastructure is far from finished. In the image of the Transition Management Diagram, the cog has turned once.

Sustainability should be thought of as a journey of discovery rather than a fixed goal that can be worked towards. The quest for sustainable outcomes will generate new knowledge areas as well as identifying gaps where knowledge does not exist. Ways of filling these gaps can be built in to the next round of transitioning.

Throughout the process, the Learning Alliance is seeking more sustainable solutions and this can only be achieved by turning the cog once more and going round the transition management cycle again....and again....and again.

New visions must be sought, and new actors need to be found who are ready to become the champions of the future.

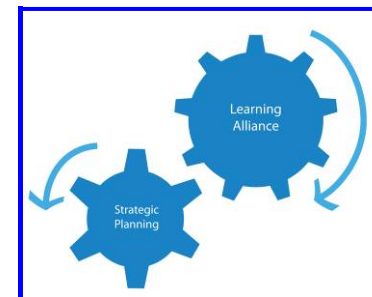

The Learning Alliance drives each round of transitioning

## *Section 4*

# *Strategic Niche Management*

## *The Demonstrations*

## Strategic Niche Management



Strategic niche management and experimentation are vital for the delivery of sustainable systems as they provide the scope and pathways for a transition to occur. Niche management requires the nurturing of technological innovations by the Learning Alliance (LA). This should take

place in the transition arena through delivery of a strategic plan or transition agenda.

The concept of a niche has its origins in ecology but the idea is relevant in many complex systems. In ecology it is; *'The role an organism plays within the structure and functions of an ecosystem, and the way it interacts with other living things and with its physical environment'* ([www.nelson.com/](http://www.nelson.com/)). Most definitions such as this presume that an organism resides in its own niche and the analogy is appropriate in the very complex world of water management which has many different layers of technical and human interaction.

The niche might be a process, a piece of equipment or an innovation that plays a role in the overall system. Integrated urban water management is a world with a vast number of interactions between people, objects and ideas, each of which has a life of its own and where a change to one will have an impact on many others. As the amount of integration increases, the interactions between niches become greater in number and a change in one may impact on more and more.

A new idea, equivalent to the organism, may require a particular problem to be resolved before it can occupy its niche in the city otherwise it will not develop and grow in numbers. It is the role of

researchers to solve such problems and this is one of their key roles for the LA. The problems are resolved through carrying out field work, testing, analysis or modelling and reporting back on the results. Normally, researchers are keen to find new problems and will willingly take part in these niche management activities. The figure below illustrates this interaction of researchers and the LA.

The **SWITCH** project identified a range of demonstration projects in 10 cities. Each demonstration project addressed a problem in the city. Their purpose was to show the stakeholders in the LA clearly how things could be different in the future.

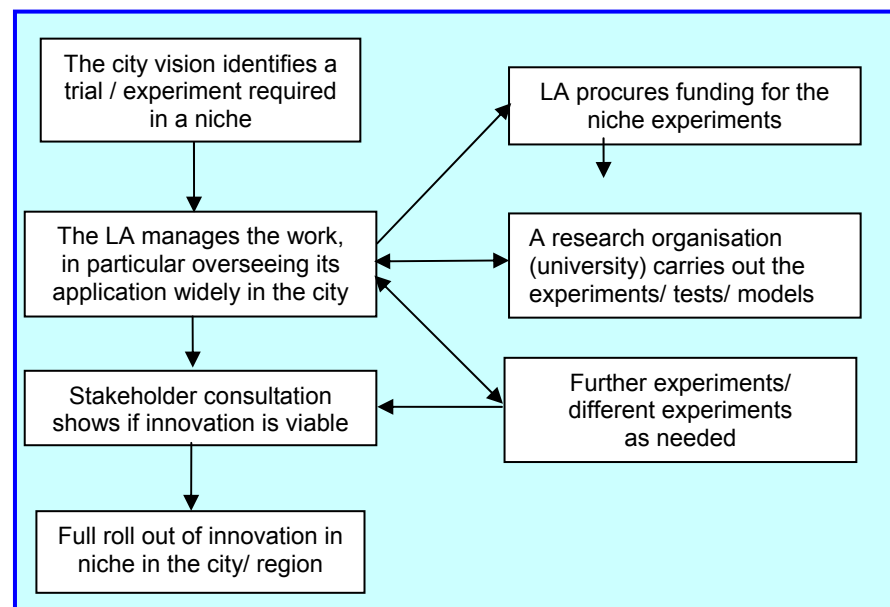

### Nurturing experimentation in a niche

The results of experimentation will be positive most of the time, but sometimes they will not. Successful niche nurturing will ensure that the lessons learned from the experiments, positive or negative, will lead to new ways of working in the city.

### SWITCH Demonstrations

Many demonstrations were developed in the **SWITCH** project and it is important to see what lessons were learned in changing the management of water systems in the cities. There are also many more excellent city case studies worldwide, some of which are highlighted in **SWITCH** deliverable 6.1.5 – ‘Successful Transitioning Stories’.

A demonstration might take a number of forms, each one capable of bringing something new to the city. It might be;

- A new product;
- A design;
- An installation;
- A method of management;
- A method of analysis.



**The road to innovation**

The purpose of a demonstration is to show how the local example will work throughout the city. In many cases the innovation will not be new in an absolute sense but it certainly will be new in that particular country or city. There will be many issues locally which may make the idea difficult to apply in a particular city. Typical problems that may have to be negotiated are; insufficient resources available, the lack of trained personnel for maintenance, local customs to list just a few.

### Scaling Up

Once the ideas have been successfully demonstrated, they will need to be scaled up and rolled out. The demonstration will not be sufficient to show how the innovation will work throughout the city without scaling up. The demo itself will probably be quite small and, although it will be relevant, it needs to be shown that it will work on a broader scale before it can be rolled out or applied throughout the city. Hence it must be scaled up prior to roll out.

Research and innovation needs support. This should be provided through the Learning Alliance (LA) on the basis that their experiments can impact beneficially on the water systems. It is by no means certain that all experiments will be successful but, although failures will occur, good ‘niche management’ by the LA will ensure that time is not lost and schedules for the introduction of the new innovation are kept. The purpose of city demonstration projects is to show how the research can be applied to the benefit of the city – how the innovation will work and how it can be rolled out throughout the city/ region.

Scaling up requires wide collaborations throughout the city since many partners will need to become involved. If the innovation requires to be incorporated into new developments (for example sustainable drainage) all key developers in the city must engage with the new ideas so that all are seen as being treated equally. On the other hand, if change are to be made within properties (for example water save devices), then all householders must be informed about the changes through media campaigns.

## Water Quality Projects in Tel Aviv

### Outline of Demonstration Project

The aim of this project in the Tel-Aviv area was to improve the safety of the reuse of effluent above conventional systems.

The demo project utilised effluent treated in a conventional activated sludge system as input to a hybrid soil-aquifer treatment (SAT) system with 30 days retention time. This was followed by Nano-filtration polishing. Tertiary effluents were further polished by a wetland system and were mixed with fresh water from rivers for recreation uses. The treated effluent is later filtered and disinfected and used for irrigation of parks and for agriculture.



### Drivers for the Demonstration Project

Israel needs to solve the water shortage constraints in this semi arid region. By using improved treatment methods, treated effluent can be used for irrigation and the amount of water supplied by the desalination of sea water would be reduced. In turn, this will reduce the cost of water supply and reduce the amount of energy used.

### Project(s) in the Demonstration

The Shafdan treatment plant (Activated Sludge + Conventional long SAT), which is relatively cheap but provides a high level of treatment, has been used for irrigation in the south of Israel for more than 30 years. The demonstration project was to develop an alternative short SAT+ NF hybrid system. The demo showed the following:

- Micropollutants can effectively be removed by the short SAT – NF 270 process, obtaining a safe and high quality water.
- The short SAT - NF-90 process produced an almost RO quality water

### Learning Alliance Role

Different bodies in the water authority sector were already communicating with each other before the LA concept was brought to their attention.

The city of Tel Aviv has a number of long standing multi-stakeholder platforms related to water problems dealing with the most important current and future water issues including key organisations managing the issues of drinking water supply and distribution, storm-water, wastewater collection and treatment, effluent supply and water reuse.

### Scaling up

The greatest potential for having a visible and sustainable impact on IUWM in Tel Aviv Water will be the inclusion of improved indicators in the City Master Plan. This will also provide support to the Water Authority and other LA members, not just for monitoring water issues at the city level, but also to introduce these indicators at the national level.

There is an increasing interest in the occurrence of micro-pollutants in water and how to cope with them. This demo project will be very useful to inform the debate on micro-pollutants.

The development of the LA in Tel-Aviv showed that relations between the different authorities and the water suppliers and water users were already in a mature state before the start of the LA. However, the **SWITCH** thinking helped to consolidate the relations and to concentrate efforts on one or two major items to produce results in a short time.



### Ma'awa Sayadeen (Fishing Village) in Alexandria, Egypt



#### Outline of Demonstration Project

Alexandria is Egypt's second largest city and urgently needs integrated water management. Ma'awa Sayadeen is an informal settlement comprising a fishing village in a slum area currently without an adequate public sewerage system. Its area is about 65 Feddan  $\approx 273,000 \text{ m}^2$  and the population is approximately 10,500.

The current project involves piloting of the most appropriate technologies and strategies for water sensitive design including decentralised wastewater treatment, demand management, rainwater harvesting and water reuse. This will reduce the amount of sewage discharged into and the pollution in Lake Maryut.

#### Drivers for the Demonstration Project

- Improvement of the treatment of wastewater in the nearby wastewater treatment plant;
- Increased treated water availability for agriculture;
- Improving the livelihood of village residents.

#### Projects in the Demonstration

- Baseline study of the existing situation to identify current practice, problems and priorities.
- Student research on alternative unconventional urban sanitation systems in the area.
- Social Inclusion. The demonstration village is intended to be an example of consultative and inclusive planning processes between the community and city authorities with regard to water and sanitation needs and provision. It is a focal point for institutions with water related responsibilities to engage with end users, particularly the poor and marginalized, in identifying needs and priorities, planning action and in implementation.

#### Learning Alliance Role

Members of the LA identified possible locations for demonstration sites in Alexandria. Specific criteria for the demonstration site, was imposed on the selection committee comprised of LA members. LA members have been involved in the decision making process for the demo site project.

#### Scaling up

This demonstration site will act as a pilot project for future projects in other sites around Alexandria and Egypt.

A policy briefing paper with the outcomes of the demonstration project, along with its strengths and weaknesses will be compiled at the end of the project to be used for future areas in Egypt.

## Demonstration Projects in Łódź

### Outline of Demonstration Projects

There were two **SWITCH** demonstration projects in Łódź that very clearly supported the vision of the city, which was to attract foreign capital to the city and to develop new markets. This was to be achieved by revitalising urban areas together and improving local and regional transport.

For the water sector, this meant that neighbourhoods close to a number of streams that pass through the city would need to be improved. The vision saw this improvement as an opportunity.



Pond improvement by  
Sokolowka River



Tree Development

#### Demonstration Project 1:

Restoration of a municipal river to manage stormwater better, improve water quality and improve the quality of life.

#### Demonstration Project 2:

Promotion of biomass growth through the utilisation of sewage sludge.

### Drivers for the Demonstration Projects

The technical strategies revolved around attenuating water flowing from the City through constructing SUDS/BMPs for stormwater management, rehabilitating rivers and improving green areas. The operation of the wastewater treatment plant would also need to be improved and the amount of pollutants discharged to the Baltic Sea reduced, thereby satisfying the requirements of the EU Water Framework Directive.

### Scientific studies stimulated by the Demonstration Projects

The first demonstration project stimulated a number of studies;

1. **Hydrological, physico-chemical and biological monitoring:** Analysis of the seasonal and spatial distribution of PCBs, PCDDs and PCDFs and cyanobacterial blooms toxicity - risk assessment for health and quality of life.
2. **Dynamic of toxic cyanobacterial blooms:** water retention and purification in rivers; stream channel rehabilitation; landscape validation and mapping of real vegetation.
3. **Use of sewage sludge for bioenergetic plants fertilization and optimization of fertilizer composition:** Groundwater effect on biomass production and heavy metal removals by plants, economic aspects of bio-energy production.
4. **Water balance in urban catchments:** Stormwater management and BMPs, Effect of urban landscape development on human health.

## Section 4 – Strategic Niche Management



### Phytoremediation at Teresa and Zgierska and Wycieczkowa lakes

The studies undertaken are all examples of the key issue in Łódź, which is improving accessibility to and the quality of the local watercourses and lakes.

### Learning Alliance Role

Assembling the **SWITCH** Learning Alliance in Łódź was the first attempt to improve communication between different organisations. It provided a cross-institutional platform to share information and discuss water and sanitation issues. It was able to give an overall picture of how different organisations work together in the city and enabled issues to be addressed in an integrated way for the first time in Łódź.

### Scaling up

Integrated surface water management was linked to new developments in the city and showed developers how integration works in practice. New neighbourhoods will be developed alongside the Sokolowki Park recreational area.

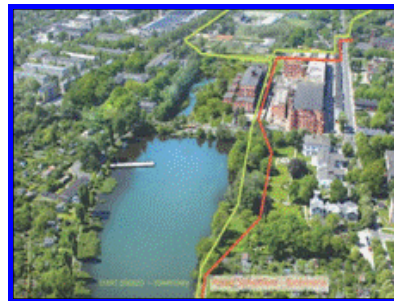

The rehabilitation of the rivers was 'badged' as the **Blue-green network**. This city-wide rolling out of linked improvements was seen as being essential for the improvement of environmental quality and safety of the local communities. The presence of eighteen rivers gave great opportunities for carrying out a range of similar projects around the city including improving ecosystem service provision, greater recreational areas and more attractive areas. These are all elements of the scaling up philosophy and in future will lead to improvements of the quality of life and health of the citizens in a sustainable manner.

The project team worked closely with developers to integrate stormwater management into planned re-developments using the ideas developed in the pilot studies. The developers were able to identify the costs and benefits associated with the SUDS/BMPs and how they could improve the areas.

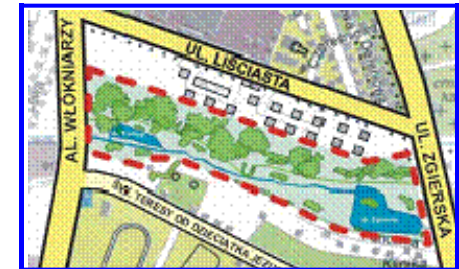

Sokolowki Park

Recommendations were made for changes to the city local development plan and strategic documents in Łódź. These were developed in the participatory process at **SWITCH** Learning Alliance working groups. In particular, regulations were improved covering;

- Stormwater management
- How to make the Blue Green Network a reality.

## Demonstration Projects in Belo Horizonte

### Outline of Demonstration Projects

Two demonstration projects were undertaken in Belo Horizonte;

#### 1. Rainwater Harvesting Project

The purpose of the rainwater harvesting project was to:

- Develop rainwater harvesting software to appraise the project and simulate the pay-back period using net present values.
- Evaluate the use of rainwater harvesting at schools, private houses and in urban agriculture.

The rainwater harvesting demo project involved:

- Setting up a demo site.
- Developing software for rapid assessment of new sites.
- Rolling out rainfall harvesting ideas throughout the city.



Installing a tank for rainwater harvesting

**Computing the optimal tank size**

Empty tank vs time | Cost | Rejected water vs size | Rippl diagram  
 Data | Data (2) | Savings | Water substituted | Water non substituted | Empty tank vs size | Mensual consumption | NPV vs time | NPV vs size

Type:  School  Household  Customised

Please indicate surfaces in m<sup>2</sup>

Runoff coefficient: 0.83

Surface of the roof: 1990

Surface of grass: 1190

WC type:  valve  tap

Surface of the kitchen garden: 0

Classrooms' total surface: 1355

WC's total surface: 260

Playground surface: 1325

Surface of the stairways and corridors: 720

Surface of the outdoor sport yard: 920

Surface du parking: 0

Canteen's surface: 240

Rainfall data: 8

Information:  Hourly  Daily

Time period (years, < 14): 14

Number of people:

	Students	Professors	Staff
Period 1	960	24	15
Period 2	960	24	15
Period 3	150	4	3
Total during the week-end	290		
Total during holidays	360		

The school opens during holidays?  Yes  No

Spreadsheet for the determination of optimal tank size

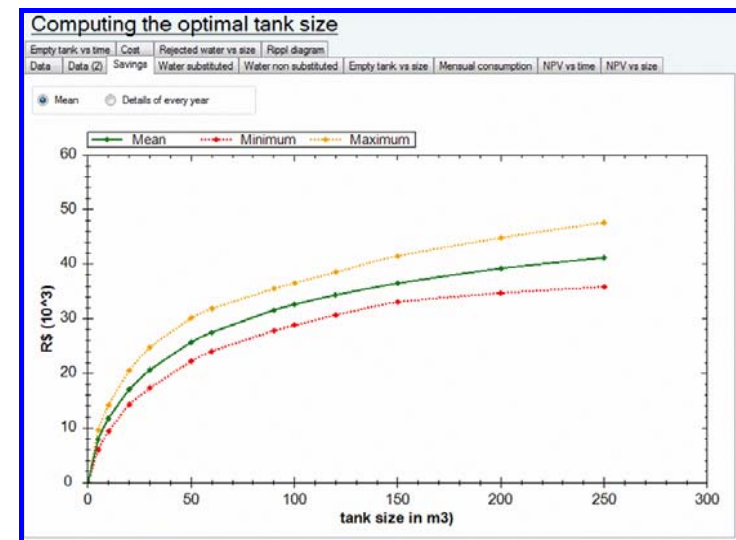

Design graphs for rainwater harvesting tank size determination

### 2. Filter Drains for Highways

The purpose of this project was to develop designs of better surface water drainage systems for highways in Belo Horizonte. This demo project involved;

- Evaluating designs.
- Building a demo site.
- Developing standard costs for capital and operation and maintenance.
- Retrofitting a system that meets roads standards.
- Showing how responsibilities can be shared with developers.
- Running a training programme for engineers and technicians.



Demo filter drain in Belo Horizonte

### Drivers for the Demonstration Projects

There were a number of high level drivers for the projects in Belo Horizonte:

- Regulating land use according to stormwater requirements.
- Payment for environmental services.
- Local taxes as a way of promoting the use of BMP.

### Learning Alliance Role

The LA in Belo Horizonte very strongly and actively supported the demonstration projects in the city and region.

### Scaling up

There is close association with the local and regional governments through the LA and the Scaling up for the Metropolitan Region. A training programme for engineers and planners was set up to improve awareness, skills and utilisation of the concepts.

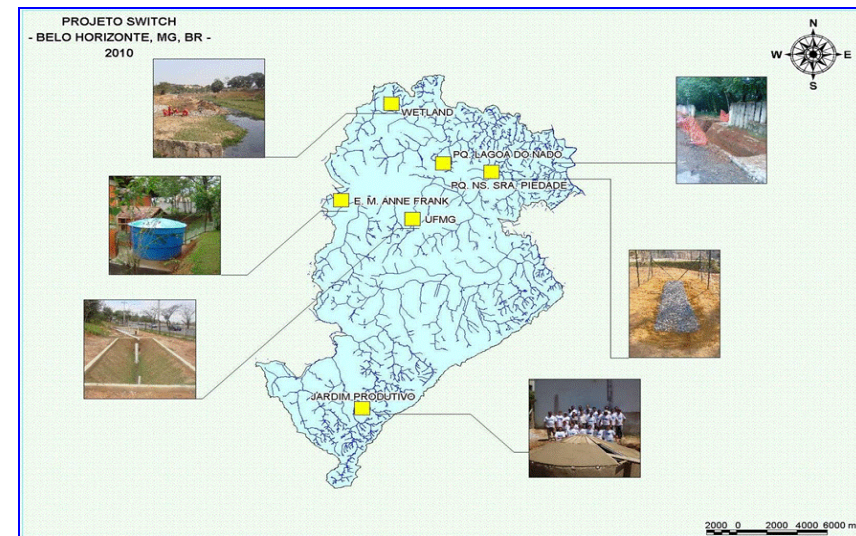

Location of demo projects throughout the Belo Horizonte region

# Demonstration Projects in Birmingham

## Outline of Demonstration Projects

### 1. Assessing flash-flood risks

An assessment of flash flood risks in the Upper River Rea catchment was undertaken by the University of Middlesex Flood Hazard Research Centre with the aim of developing a range of BMPs for stormwater management. The catchment has an area of approximately 1,800 ha with a population 70,000. Records show that there have been floods in the area since the beginning of the 20th century. The most recent episodes caused severe damage to infrastructure and a deterioration in the quality of life for the locals.

The flood behaviour of the catchment is complex and varies from peri-urban flooding to river flooding and sewer overflows. The flood locations are shown in the figure below.



Upper Rea flood risk zones

SUDS	Soil permeable	Soil impermeable	Effective contributory area < 1 ha	Effective contributory area 1 to 2 ha	Effective contributory area 2 to 4 ha	Effective contributory area > 4 ha
Greenroof						
Porous pavement						
Swales						
Infiltration trench						
Detention ponds						

SUDS site constraints



Estimated sewer flooding for a 1 in 100 year event

Criteria	Indicators	Greenroof	Porous pavement	Swale	Infiltration trench	Detention ponds	Weighting indicators (%)	Weighting criteria (%)
Hydraulic control	Runoff volume reduction	3	3	2	3	1	5	30
	Runoff flow rate control 1/2 year event	3	3	3	3	3	5	
	Runoff flow rate control 1/30 year event	3	3	3	3	3	5	
	Runoff flow rate control 1/100 year event	1	1	3	1	3	15	
Water quality	Total suspended solids	1	3	3	3	2	10	20
	Heavy metals removal	1	3	2	3	3	5	
	Nutrient removal	1	3	2	3	1	1	
	Bacteria removal	1	3	2	2	1	2	
Response of system to climate change	Capacity to treat fine suspended solids and dissolved pollutants	3	3	3	3	1	2	20
	System reliability and durability	2	3	3	2	3	20	
Social and economic factors	Maintenance	1	2	3	3	3	5	20
	Costs	1	2	3	3	3	10	
	Community acceptability	3	2	2	2	3	3	
Risk of failure and Urban planning	Habitat creation potential	3	1	2	1	2	2	10
	Adoption Status	2	2	3	2	1	5	
	Building development issues and stormwater regulations	2	1	2	2	1	5	
<b>Totalscores</b>		<b>369</b>	<b>428</b>	<b>402</b>	<b>426</b>	<b>303</b>	<b>100</b>	<b>100</b>

SUDS decision matrix

### 2. Birmingham Green/ Brown Roofs

This demonstration project was led by the University of Birmingham working with a range of other interested agencies. An experimental array for exploring different brown roof materials and their impact on biodiversity and hydrology was erected on the University campus. In total three brown roofs were planned in the project, two of which were assembled; 1 on the International Convention Centre (ICC) and a second on the Birmingham Volunteer Service Council building. Unfortunately the projects suffered from the constraints of a very short timescale for strong partnerships, and the bankruptcy of one of the partners.

### 3. Groundwater-surface interactions

Two part-projects on groundwater ran in conjunction with the Environment Agency, a key member of the learning alliance.



Flow measurement in River Tame



Groundwater pumping test

Research on the River Tame, a heavily modified watercourse flowing through Birmingham crosses the major aquifer beneath the city, has provided understanding of the natural remediation of pollutants at the river-aquifer interface when groundwater contaminated by pollutants enters the stream. The advantages for this is that it potentially offers a natural system for self-purification of the urban water cycle and cost-effective treatment of discharging groundwater plumes in river base flows.

A second **SWITCH** research project examined the occurrence and mobility of viruses in groundwater and their potential risks to health. The aim was to assess the risk to drinking water supplies if treated wastewater is injected into the aquifer. It is important to qualify and quantify such risks before exploiting underground reservoirs.

#### Drivers for the Demonstration Projects in Birmingham

Birmingham is a heavily urbanised city, with rising groundwater. Pluvial flood risk is a concern within the city, like many other UK towns and cities.

These studies will help to inform the City Planning Department and the Drainage Department, British Waterways, the Environment Agency and Severn Trent Water Company in planning, reviewing and implementing this vision as developments are brought-forward through the planning process.

#### Learning Alliance Role

This is being encouraged by the City Council for the Eastside regeneration area and SWITCH is assisting in defining the risks and uncertainties and helping to create a “Vision for Surface Water Management for 2030” in Eastside.

#### Scaling up

The studies did not reach the scaling up stage before the end of **SWITCH** in Birmingham but in a heavily regulated city this is not unsurprising. Tools have to be tried and tested before they can be introduced into the main stream.

Due to changes in legislation in England & Wales, the lead agency for urban flood risk will be local authorities. Tools such as SUDSLOC will take a key role in assessing the risk of flooding and give an understanding of green interventions to mitigate some risk.

Developers have contacted the green roof team via LA website to understand the benefits of a green roof and how they can bring green infrastructure into their developments.

## The Applicability of Innovations in Global Cities

The **SWITCH** Global City Water Futures Summit was held in Delft, The Netherlands on 7-10 October 2010. This meeting was attended delegates from a wide range of cities worldwide. As part of the activities, delegates were asked to complete a matrix of innovations and their applicability in different cities. The innovations could cover all types of new ideas whether natural, technological or managerial. Many of the innovations were 'green' systems incorporating energy efficient principles and natural systems. Delegates were advised to be realistic about the constraints to the uptake of the innovations and the likelihood of their implementation.

Each city delegate was given a common set of instructions and was encouraged to be frank about their city. A large poster was set up showing a matrix of innovations and cities with boxes to insert appropriate stickers. For their city, delegates were asked to:

- Assess their interest in adopting the innovation identified. For positive interest apply a yellow sticker in the appropriate column below the innovation on the line for your city.
- Indicate perceived difficulties/constraints to implementing the innovation in your city using the appropriate coloured sticker in the appropriate column below the innovation on the line for your city.
- Ensure that the stickers applied are a collective decision taken with the whole of the team representing your city at the summit.



The innovations considered in the matrix were:

- Soil aquifer treatment and aquifer recharge.
- Rainwater harvesting.
- Grey water recycling.
- Green / brown roofs.
- Pond / wetlands.
- Urine separation and use.
- Waterless toilets.
- Water saving devices.
- Community level wastewater treatment plants.
- Intermittent service delivery.
- Urban Agriculture.

The resulting matrix, following completion by delegates and shown on page 61, shows an interesting snapshot of the potential for innovation in the water sector in cities around the world.



Key to matrix of applicability of innovations



## Section 4 – Strategic Niche Management

Innovation												
City	Soil aquifer treatment and aquifer recharge	Rainwater harvesting (tanks etc)	Grey water recycling	Green / brown roofs	Pond / wetlands	Urine separation and use	Waterless toilets	Water saving devices	Community level wastewater treatment plants	Intermittent service delivery (ex. Good pressure but only 3 hours/day)	Urban Agriculture	
1	Aoora											
2	Belo Horizonte											
3	Birmingham											
4	Bogata											
5	Call											
6	Cape Town											
7	Cape Town											
8	Dhaka											
9	Durban											
10	Dunedin											
11	Kampala											
12	Kisumu											
13	Lima											
14	Lódz											
15	Lusaka											
16	Melbourne											
17	Sana'a											
18	Tel Aviv											

Matrix of Applicability of Innovations in Global Cities



# *Section 5*

## *Transitioning Stories*

### *Four SWITCH Cities*

## The SWITCH Case Study Cities

Four **SWITCH** cities were chosen to find out how they have historically made changes to their urban water systems, how they attempted to transition urban water management practices during the **SWITCH** project and if it might be possible to show how changes leading to more integrated urban water management might occur in future. A particular challenge was to determine whether or not any change had been influenced by the **SWITCH** approach and to hypothesise if any change(s) might last. Through our analysis, we consider that there was movement along the Transition Curve (see page 68) in Łódź and Belo Horizonte.

### Progress made by the cities

An evaluation of progress is always difficult in an analysis of this nature because of the widely different characteristics of the four cities selected. However, we consider that the better progress in Łódź and Belo Horizonte (BH) was due to a number of key factors that strengthened the transition and niche management processes:

- There was full time Learning Alliance facilitation to organise the stakeholders. (Accra and Łódź).
- Transition arenas formed where champions encouraged integration and gave leadership to the group driving the change process. (BH and Łódź).
- Transition agenda building occurred early on in the process. This was primarily due to building on existing windows of opportunity; i.e. building on other projects and initiatives. (BH and Łódź).
- Better progress occurred where there was political buy-in, and social inclusion was an integral part of the Learning Alliance strategy. (Accra, BH and Łódź).
- Active relationships between researchers and stakeholders were nurtured. (Accra, BH and Łódź).

- The **SWITCH** approach was successfully embedded in city decision making. (BH and in Łódź to a small extent).
- The media became involved, sustaining the transition and paving the way for wider dissemination of the process, thus potentially facilitating scaling up within a city. (Accra, BH and Łódź).

### SWITCH City Activities

A range of experiments, primarily at demonstration sites, were carried out in each of the four cities. These activities are a critical part of the **SWITCH** process. They show a city which activities are most likely to be successful since they are new to that city and require organisation and monitoring. Collectively this process is called niche management and the demonstration activities undertaken in each city are summarised in the box below.

#### SWITCH City Stories – Strategic Niche Management

**Accra, Ghana** – Demo site: Dzorwulu / Roman Bridge farming area. Water reuse and nutrient recovery in urban agriculture. Social inclusion for water supply decision making processes.

**Alexandria, Egypt** - Demo site: Fisherman's village. Water demand management. Social inclusion. Public-Private (NGO) Partnership

**Łódź, Poland** - Demo site: Sokołowka River. Upgrading water networks through river restoration using eco-hydrology and WSUD principles. Upgrading sewerage networks and closing the nutrient cycle by using sewage sludge to grow energy crops.

**Belo Horizonte, Brazil** – Demo sites: DRENURBS, Vilarinho area and Pedro Guerra school, Anne Frank school. Retrofit wetland and detention basin. River restoration and detention basin. Rainwater harvesting and water re-use. Social inclusion.

## City Images

Most cities are seen through images and phrases. Some key pictures and words are selected here to reflect the four **SWITCH** cities studied.



Accra - Independence



Alexandria Pearl of the sea



Łódź Boat



Belo Horizonte Beautiful Horizon

## ACCRA Water Service Delivery

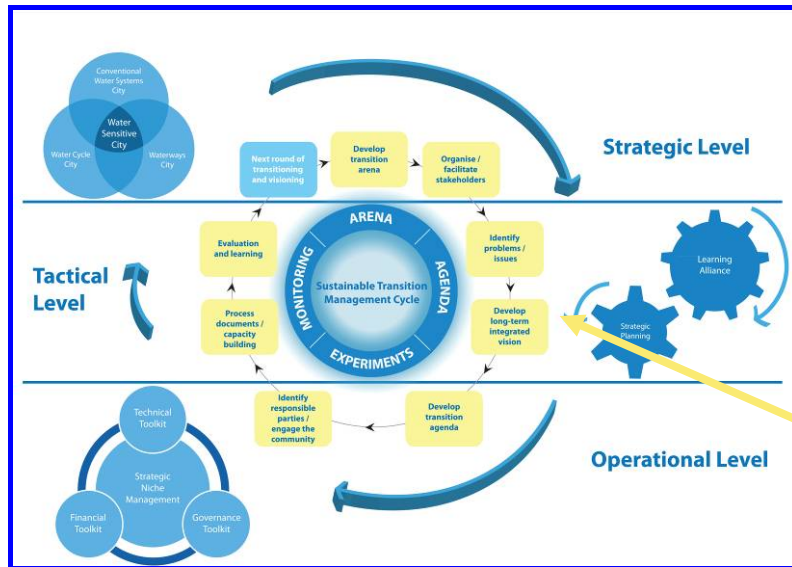

## ALEXANDRIA Towards IUWM

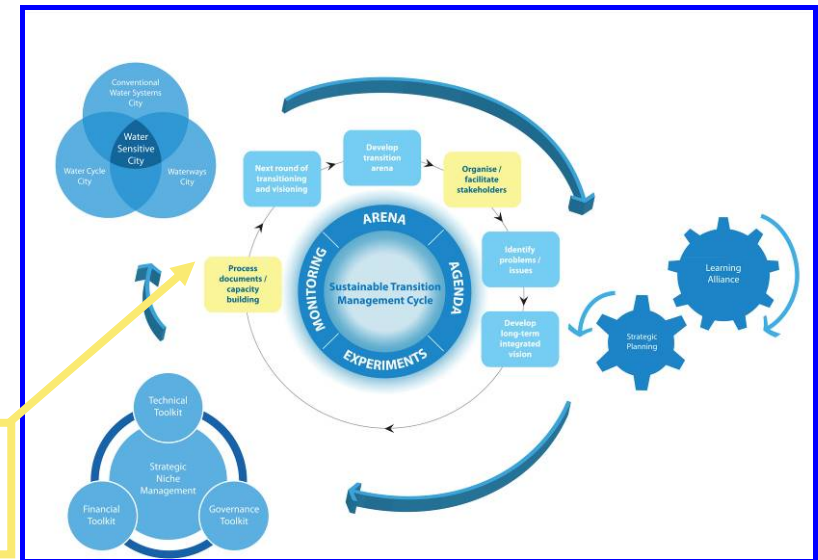

### Accra Transitioning Strengths

- IUWM transition arena developed. Key organisations and water issues identified.
- Improving service delivery vision, scenarios and transition agenda (strategic plan) developed. Strategies identified to improve water supply and sanitation services.
- Responsible parties / stakeholders identified and media briefings to go forward with the vision and implement strategies.
- Process documentation, evaluation methodologies and capacity building programme developed to facilitate transitioning process.
- **NEXT round of transitioning should focus on further experimentation with innovations.**
- **Implementation of Strategic Plan .**

### Alexandria Transitioning Strengths

- Key organisations and water issues clarified and documented.
- IUWM vision agreed with two further detailed visions for water supply and sanitation. Scenarios developed. Transition agenda (strategic plan) almost complete.
- Two demonstration projects in slum areas.
- Process documentation developed, responsible parties identified and media briefings to raise stakeholder and public awareness.
- **NEXT round of transitioning**
  - ✓ **Finalising and delivering the transition agenda.**
  - ✓ **Implementation of transition experiments.**
  - ✓ **Develop monitoring and evaluation methodologies.**

## ŁÓDŹ, Consolidating IUWM

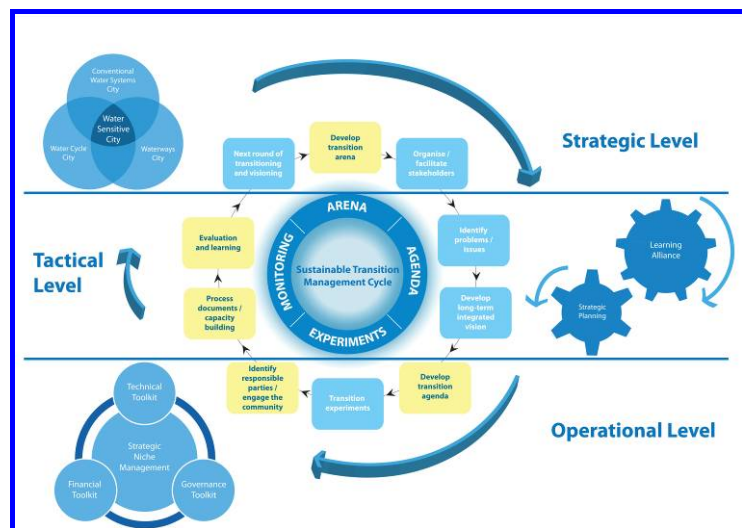

## BELO HORIZONTE Improving Integration

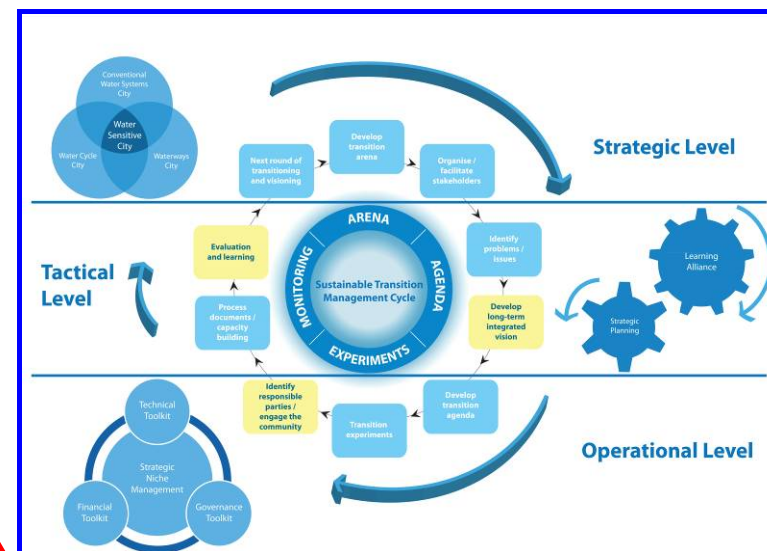

Next round of transitioning

### Łódź Transitioning Strengths

- Transition arena strengthened during **SWITCH** with key players now in place.
- Strong transition agenda with IUWM focus.
- Strong strategic planning.
- Responsible parties / stakeholders identified and media briefings to go forward with the vision and implement strategies.
- Process documentation, evaluation methodologies and capacity building programme strengthened during **SWITCH**.
- Evaluation process and lesson learning from experimentation underway.
- **Sustain up-scaling of innovations across the other 17 rivers in the city for the next round of transitioning.**

### Belo Horizonte Transitioning Strengths

- There is a strong transition arena.
- The vision is developed with a focus on IUWM.
- Strong strategic planning.
- Process documentation preparation strengthened during SWITCH.
- Evaluation methodologies were strengthened during SWITCH.
- A capacity building programme was put in place during SWITCH.
- Rolling out and scaling up of the transition experiments across the city commenced.
- **Continue to up-scale innovations across the city and other municipalities for the next round of transitioning.**

## Analysis of Water Service Delivery

The transition study for each city was split into three research phases (Brown et al, 2008). The first step involved reconstructing historical urban water management transition pathways for each city. The development of urban water services from early 20th century to the beginning of the 21st century were analysed. Next, progress within a city as it attempts to move towards more sustainable practices in urban water management from 2000 to 2010 was evaluated. This stage also highlighted the transitioning impact of the **SWITCH** approach which commenced in 2005, a relatively short time-scale from a transitioning perspective. The third step involved 'future's' research that projects one or several trajectory paths that a city might take towards delivering more sustainable urban water management practices for the city of the future. The third step is not about predicting the future but maps out a range of possibilities of achieving sustainable outcomes that help cities become smarter.

Scenarios show where a future intervention may assist in achieving goals. They set out how, potentially, the future might be shaped, by providing pathways of possibilities and encouraging a change in thinking. The four city stories show the different transitioning stories through the three phases. Although greater detail is given for Accra, each city has a parallel story:

- Key events in the water service delivery timeline (historical analysis).
- Current strategies to move the agenda towards a more integrated approach to water services delivery (current analysis).
- A future's analysis which maps a potential continuation along the transition trajectory for delivering improved water services.

## The Transition Curve

A significant movement along the Transition Curve during the **SWITCH** project was evident in all the cities, as is illustrated in the figure opposite. Accra is poised to move into the take-off phase if the transition momentum instigated by **SWITCH** is sustained. Alexandria is technologically locked-in with a culturally dominant stable infrastructure. Both Accra and Alexandria

have greatly benefited from the transition strengths gained in process documentation encouraged by **SWITCH**.

The good process documentation in **SWITCH** led to clearer understanding of the issues and the related costs. The development of integrated strategies in Alexandria, combined with a commitment to niche development through the proposed demonstrations are evidence of a change towards more sustainable solutions.

The benefits of the Learning Alliance were most clear in Łódź where a strong relationship between city and university was established.

Belo Horizonte '*has always been a city of the future*' as is reported in the city assessment since it was the first modern planned city in Brazil. It already had strong transitioning strengths to build on and continue its transitioning trajectory during the SWITCH project.

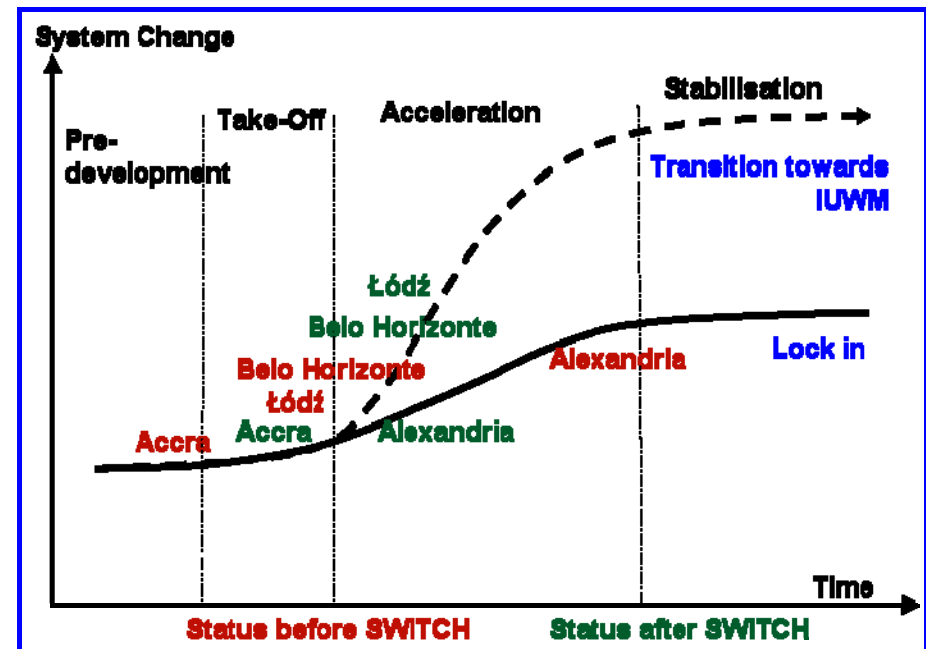

Four SWITCH Cities on the Transitioning Curve



### Barriers to progress in the cities

A number of barriers to implementing change were uncovered through the analysis of the cities. The key barriers were found to be as follows:

- Slow progress with overcoming challenges such as mobilising and motivating stakeholder collaboration. (Alexandria).
- Delays to implementing research due to slow progress with initiating the transition arena and developing agendas. (Alexandria, Accra).
- Lack of funds for experimentation. (Alexandria, Accra).
- Activities that did not match the city's cultural norms. (Accra).
- Technological lock. Limited sharing of information and progress. (Alexandria).
- Language barriers for effective communication of global information and knowledge transfer at the grass roots level. (Belo Horizonte).

Strategic niche management was less successful in two of the cities during the time-span of SWITCH than the two remaining and the possible reasons for this are addressed in the individual city stories which are told later. The primary barriers to implementation of innovative techniques in these cities were believed to be inertia at the political level, a reluctance to move away from the current institutionalized ways of doing things, and lack of funding.

### Sources of information

All of the information provided in these city stories is from the individual City stories and assessments. Other information (primarily for Łódź) has been taken from <http://www.watertime.net/> and Wikipedia / Wapedia / IWA WIKIWATER websites.

Examples of these websites include:

[http://en.wikipedia.org/wiki/Water\\_supply\\_and\\_sanitation\\_in\\_Ghana](http://en.wikipedia.org/wiki/Water_supply_and_sanitation_in_Ghana), and  
[http://www.iwawaterwiki.org/xwiki/bin/view/Articles/2\)+ACCRA+\(Ghana\)+3](http://www.iwawaterwiki.org/xwiki/bin/view/Articles/2)+ACCRA+(Ghana)+3)

### Before you look at the city stories

At least one Learning Alliance in the four cities began to realise just how unsustainable its water systems is, particularly in the light of additional pressures that the city may be exposed to in future – particularly due to population expansion.

In the following sections we show how ‘influencing a **SWITCH** from here to there’ can be achieved by following the transition management methodology through looking at the four city stories. Analysing the interactions and feedbacks across levels and domains was important in identifying the patterns and mechanisms of transitional change and for determining the methods and ideas used to influence these patterns and mechanisms (Loorbach 2007).

The **SWITCH** intervention, presented as the transition management cycle in this manual, is a vehicle for facilitating the urban water management paradigm shift in a city. Every city transition had its own dynamics with some aspects changing slowly while, for others, the change is rapid. The evaluation of the four **SWITCH** cities shows the range of approaches and responses that can occur.

### The next round of transitioning in the cities

It is clear from the analysis undertaken that the Learning Alliances in all four cities would like to continue with the transitioning process that they have started. Key changes required for a more sustainable city of the future have been identified. Whether it is surface water management associated with improved quality of life in Łódź and Belo Horizonte or carrying out the experiments that have been identified in Accra and Alexandria, there is a confidence that the niches experimentation have is required.

## Transitioning Urban Water in Accra



Independence

## SWITCH and the present in Accra

**Population:** 2.1 million. The capital city of Ghana.

**Area:** (Region - 3,245 km<sup>2</sup>).

**Climate:** Tropical savanna, yearly average temperatures 25-28°C. Annual average precipitation: 742mm.

**Water resources:** Surface water from two main sources: the Weija system on Densu river and Kpong system on Volta river. Managed by Ghana Water Company Limited (GWCL).

**Water systems:** Water supply < 50% + tanker operators + water sachet vendors. Poor families end up paying 10 times the price of water provided by GWCL • Sewerage coverage <18% • Sewerage treatment for 8%.

**Water related issues and challenges:** Rapid growth on the fringes of the city • Development of slum areas • Water demand higher than system capacity • Poor access to proper water supply and sanitation by the poor • Rising water demand from agriculture and industry • High rates of non-revenue water in GWCL system • High losses in the distribution network • Low cost recovery for water supply services • Low reliability of GWCL (continuity of supply) • Limited sewerage systems which do not work • Polluted water resources • Many areas prone to frequent flooding due to poor drainage channels and solid waste blocking drains.

**Water Resources Management:** Mismanagement of sanitation and water supply systems • Limited provision for stormwater • Institutional fragmentation with overlapping / contradictory areas of responsibility • Lack of integrated planning frameworks and regulations.

**Transition Arena:** Learning Alliance activities • Initial scoping exercise • Stakeholder analysis • Institutional mapping • Situational analysis • LA process documentation: city webpage, workshop reports, city brochure, poster, briefing notes, media articles • City storyline • Visioning and scenario building • Accra starter kit and RIDA (Resources, Infrastructure, Demand, Access) framework • Strategic direction plan for improving service delivery and IUWM • Water demand management report • Cost recovery modelling.

**Strategic Niche Management:** Reuse of urine in urban agriculture • Treatment of wastewater for urban agriculture • governance for integrated urban water management • Social inclusion.

### Water Service Provision - Timeline 1915 - 1999

Year	Event	Factor/ Outcome	Organisation Change	Actors
1915-1928	Rapid growth due to piped water supply and construction of Accra-Kumasi railway facilitating cocoa export	piped water supply system	Water Supply Division (WSD) of Public Works Department created	Federal
1952	Construction of the Wieja Dam on the Densu river	Main source of water supply		Federal
1948-1957	Ghana campaign for independence	Ghana Independence 1957	Water Supply Division now under Ministry of Works and Housing (MOWH)	Federal
1960's (1965)	Kpong Dam on Volta river. TEMA sewerage system	Need for increased water supply and to operate and control sewerage systems	Creation of Ghana Water and Sewerage Corporation (GWSC) within the MOWH	Federal / Municipal
1972	World Bank (WB) financial support to improve environmental health	Accra central sewerage system		Global / Municipal
1990's (1994) (1997) (1999)	Modernisation / decentralization of water sector. Two independent commissions for water regulation. Strategic Investment Programme (SIP) WB Urban II and Community Water and Sanitation Programmes (CWSP). National Sanitation Policy	Water sector restructure and rehabilitation scheme. Upgrade TEMA WWTP etc. Shift from government to asset holding company and private agencies to deliver more efficient O&M of water supply systems. Increase on-site waste facilitation services	Creation of EPA, Community Water and Sanitation Agency (CWSA), Public Utilities Regulatory Commission (PURC), Ghana Water Co Ltd (GWCL), Ministry of Water Resources, Works and Housing (MWRWH), Ghana Standard Board (GSB), Water Resources Commission (WRC), Waste Management Depts (WMDs), Ministry of Roads and Transport (MRT) etc	Federal / Municipal / Private sector / Global

### Transition Pathways for Water Service Delivery

Historically the key driver at the macro level (shock change) for transitioning water services delivery in Accra was the ever increasing population. Ghanaian independence and the National Sanitation Policy (NSP) resulted in moderate political pressure resulting in a multitude of responsible stakeholders at the meso level and ad hoc (unsustainable) infrastructures at the micro level that follows a conventional UWM pathway. Although water supply services are available to approximately 50% of the population, the limited sewerage system is underperforming and 2020 targets (90% access) set by the NSP may not be attainable.

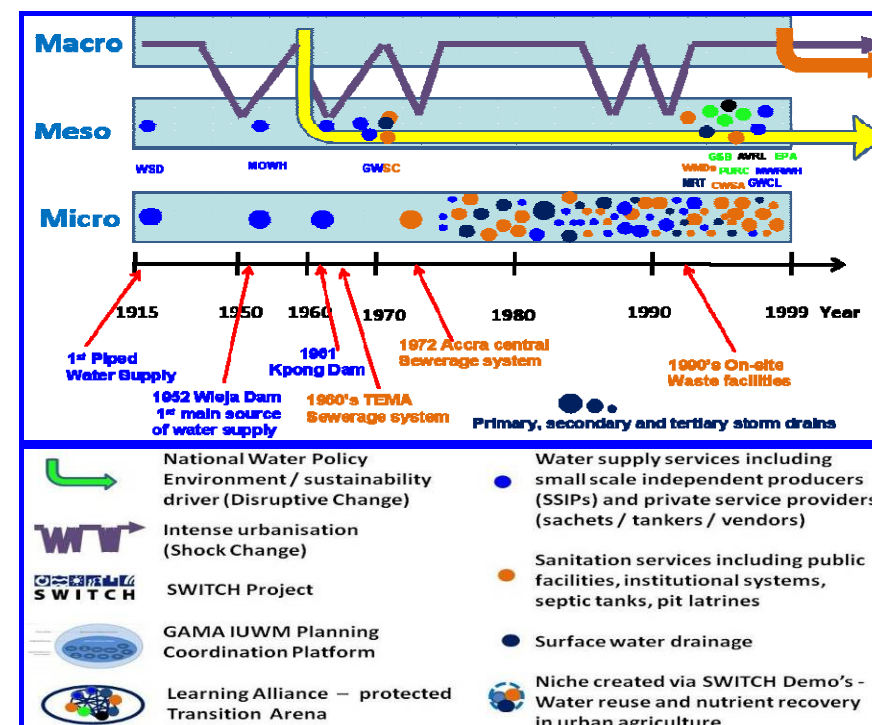

Accra 'Historical' Transition Pathways 1915 - 1919

## Towards a more integrated UWM approach 2000 - 2010

### Service Delivery and IUWM - Key Events Timeline

Year	Event	Factor/ Outcome	Actors
2000	Second joint-funded CWSP programme to increase sanitation	Biological treatment plant at James Town, additional public toilets etc	Federal / Municipal / Global
2004	Water Directorate and joint funded Urban Water Project	Provide focus and increase access to water supply for urban poor / restore GWCL stability / sustainability	Federal / Municipal / Global / private
2006	Urban water sector reforms. Joint-funded Accra Sewer Improvement Project (ASIP)	Management contract to improve water supply. Capital projects to reduce illegal connections and increase revenue	Federal / Municipal / Private sector
2006	SWITCH PROJECT begins	Desire for better service delivery through IUWM	Municipal
2007	SWITCH LA formed, activities include:	Stakeholder analysis, demo sites chosen, capacity building workshops	Federal / Municipal / Global
2007	Accra Metro sewerage unit (AMSU) created	Responsible for the sewerage system and implementing ASIP	Municipal / Federal
2008	SWITCH LA activities include:	Niche development (SNM) – 2 projects. Institutional Mapping. Social inclusion studies. Process documents / data collection	Municipal / Global
2008	National Water Policy - to overcome lack of coordination between institutions created in 1990's	Focuses on water resources management; urban water supply; community and water sanitation	Federal / Municipal/ Global
2009	LA morphed to the Strategic Planning Platform. Activities:	Stakeholder consultations. RIDA analysis. Draft IUWM Strategic plan.	Federal / Municipal/ Global
2010	SWITCH LA activities include:	Launch Strategic Direction for the Future Report – 1st meeting of GAMA IUWM Planning Platform.	
2010	AMA outlaws use of pan latrines	Prosecution from 1st Jan	Municipal

## Current Transition Pathways for Water Service Delivery, moving towards IUWM Practices and SWITCH

The key current transition driver remains rapid urbanisation where Accra continues to struggle to provide enough infrastructure for the population. Mismanagement of water supply and sanitation systems, institutional fragmentation, disregard of prevalent flooding issues and lack of co-ordinated planning frameworks are leading to an urban water system that is on the point of collapse. The Municipality and academics realised that a more sustainable approach to UWM was needed to improve water service delivery. The **SWITCH** project offered the initial step forward to realising this vision through the Learning Alliance approach.

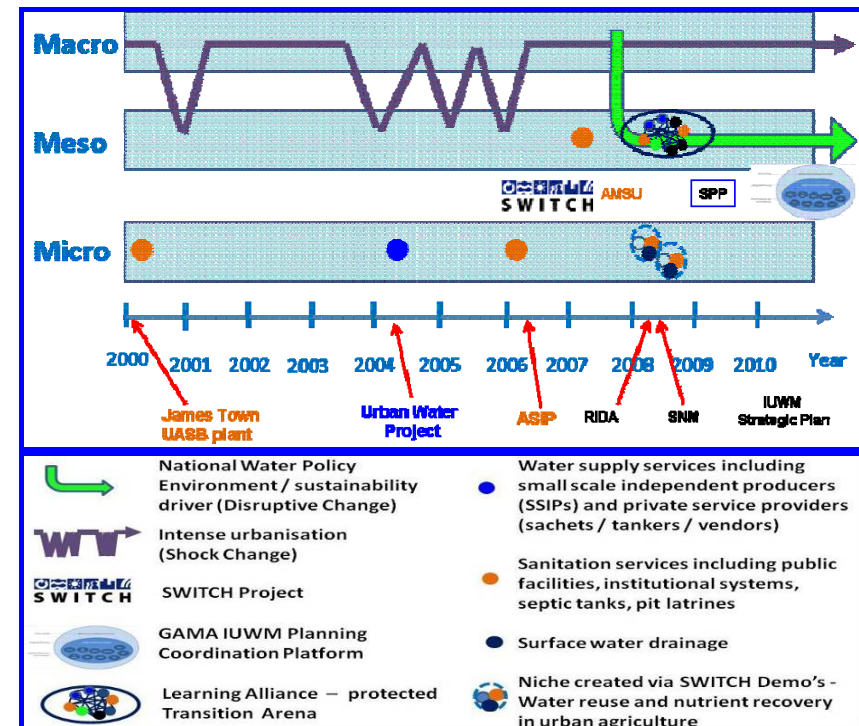

Accra 'Present' Transition Pathways 2000-2010

## SWITCH in Accra - Developing the Transition Arena

The **SWITCH** LA had a slow start in Accra since it took time to appoint and train a facilitator and develop the transition arena with relevant stakeholders. However, in early 2011, there was ‘a well balanced and vibrant’ LA operating on behalf of the city. Although the institutional framework in Accra is fragmented and ill-equipped to deal with the ever increasing complexity, transition experiments were defined. However, there were several setbacks resulting in their discontinuation.



**SWITCH Accra Webpage**

It was recognized during the strategic planning exercises that a key barrier to setting a transition agenda was that decision making processes were hampered by limited access to, or unavailability of accurate data in key areas. The decision was made to focus all efforts on obtaining suitable information and the resulting RIDA analysis (Resources, Infrastructure, Demand, Access) underpinned the report on the Strategic Directions for the Future. This document is reported to be ‘the key deliverable of the **SWITCH** Project’ and at the end of the project there was a great amount of ‘enthusiasm towards the **SWITCH** approach’.

## Strategic Planning – Transition Agenda

### Comments by LA Member - Ministry of Water Resources

“**SWITCH** held the stakeholder platform together and provided a discipline of preparing and attending meetings/workshops and this platform included wide representation. One really important aspect of the RIDA was the first time we have ever seen what the costs of the various modes of supplying water to the community are – right from the network through to tankers and sachets and this has really brought some clarity to the whole debate”

## A Water Vision for ACCRA in 2030

### Accra Vision for 2030

100% access to an uninterrupted water supply.

Water quality will meet the Ghana Standard Board criteria

Non revenue water will amount to a maximum of 20-25%

Improved water use for micro enterprises and agriculture.

80% of Accra’s citizens practise good sanitation behaviour.

70% reduction in water and sanitation diseases.

At least 80% access to acceptable sanitation facilities.

90% collection of solid waste with separation.

Accra will be a cleaner city with good drainage systems.

The Accra Learning Alliance defined the vision that by 2030 everyone in the City of Accra, regardless of their economic and social status, will have access to uninterrupted water supply, at an affordable price within a reasonable distance from their house. Currently around 80% meet this criterion and this target is a significant challenge by 2030. There are even more challenges to be faced for the provision of up to 80% access to sanitation facilities.

## Scenario Planning for 2030

Three different scenarios were put forward for evaluation and comparison:

**Worst case scenario** – Chaotic population explosion to four times that of 2007, water demand levels are six times higher than capacity, ineffective political leadership, poor economic performance, severe poverty, under investment and poor management of water supply and sanitation infrastructure, lack of water resources and reduction in river flows.

**Medium Case Scenario** - Population increases to three times that of 2007, water demand levels are four times higher than capacity, planning laws in place for urban growth, climate change has decreased water resources, lack of funding infrastructure. Confidence that solutions will be found based on improved management and empowered citizens.

**Best Case Scenario** – Population increase to 2.2 times that of 2007 with water demand levels four times higher. Changed political culture has seen enforcement of planning laws and progressive policy-making. Strong economic growth and citizens willing to pay for water and sanitation services. However, water resources are reduced and it is difficult to finance land for infrastructure, upgrades / new interventions but there is optimism for managing these issues.

## Towards IUWM in the GAMA

### Current status and strategic directions for the future report

The strategic directions report (for better and more integrated water management and service delivery in the city of Accra) endeavoured to cover all elements of the urban water cycle, rather than focusing on a specific part of the urban water cycle. This is in marked contrast to the conventional way of managing water in a city. This document presents the results of the contribution of the **SWITCH** project to the development of a strategic plan, in the form of a comprehensive RIDA analysis. The report intended to stimulate and serve as an input to the further development of an integrated plan for the management of water and the delivery of water related services in Accra. The report concludes by recommending the



creation of an enabling environment for IUWM at national level – to be called the GAMA IUWM Planning Co-ordination Platform. This platform should include enabling and regulating legislation and policies for improved urban water management. Currently at the national level, there are efforts towards a sector wide approach that focuses primarily on water supply and resources.

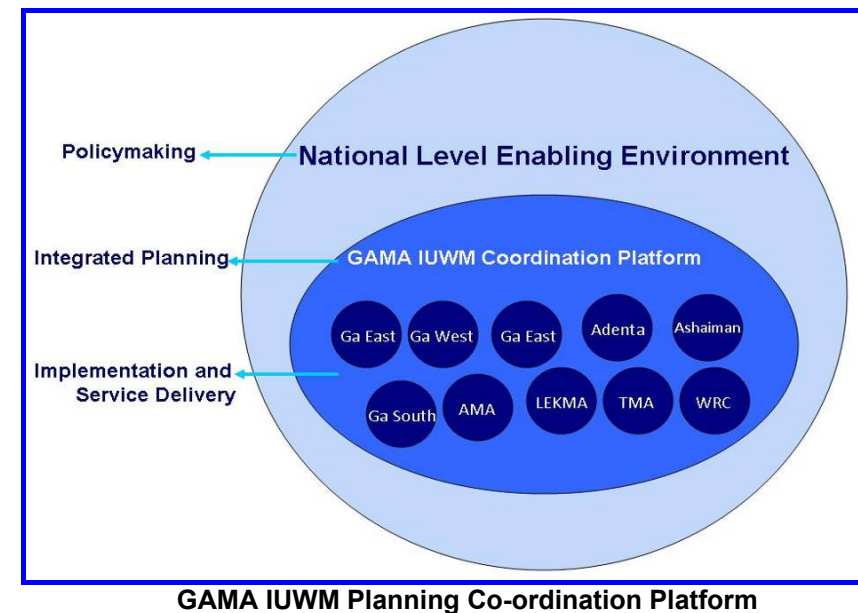

The strategic directions report recommends that a similar process is developed for waste water and sanitation, co-ordinated with water supply and resources at the national and sub-sector levels. This process could be led by the National Development Planning Commission (NDPC), Ministries of Water Resources, Works and Housing (MWRWH) and Local Government and Rural Development (MLGRD). Various sector agencies should also be involved in the process EPA, PURC, WRC etc. The NDPC is currently developing an Urban Policy and this provides a window of opportunity for including IUWM issues as a strategic direction for urban authorities.

### Transition Experiments - Strategic Niche Management

Accra's demonstrations were related to urban agriculture, which is practiced by more than 1000 farmers and provides around 90% of the city's need for perishable vegetables. It is estimated to benefit around 250,000 people daily, yielding an average monthly income of US\$ 40-57 per farm. Due to the high cost of synthetic agricultural products, many farmers use unorthodox farming practices, for example, using urban runoff from drains to irrigate crops. Unfortunately this has been associated with intestinal infections and the objective of the proposed demonstration was to test risk reduction methods to improve the health of farmers and others in the food supply chain while safeguarding public health concerns. Options for recycling human waste for agriculture using low-cost, appropriate, and decentralised treatment and production management technologies were also explored.

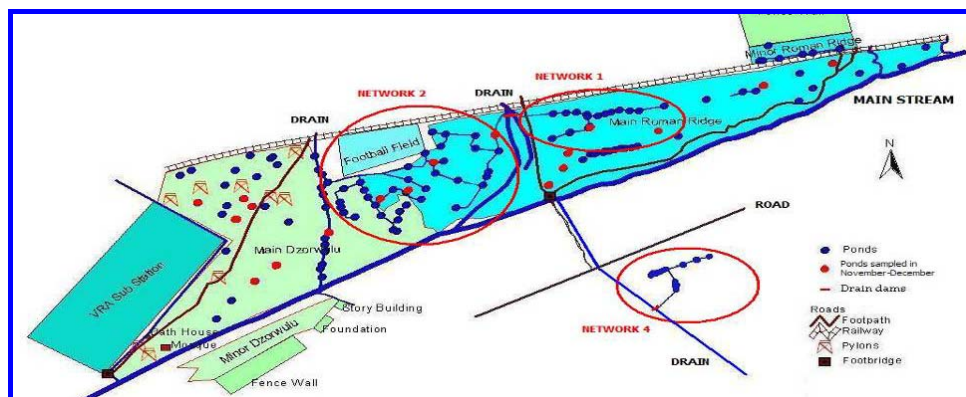

**Dzorwulu / Roman Ridge farming area study site**

Plot scale demonstrations were undertaken with farmers at the Dzorwulu-Roman Ridge site using two sources of water: wastewater mainly from drainage ditches, and piped water stored in shallow ponds for easy access. The ponds contained macrophytes as indicators of water quality, and safer irrigation practices were also explored. Public toilet facilities provided an opportunity to collect and reuse urine as a nutrient since fertilizing with treated urine can increase crop yield by up to 300%.



**Accra demonstrations**

Although the demonstrations showed that nutrient recycling worked well, the technology was expensive due to the substantial initial capital required for the infrastructure to collect, store and transport urine. All the farmers consulted were in favour of developing this innovative approach. However, although urine is a useful alternative fertiliser, the cost of bringing it to site would have been greater than using existing fertilisers such as mineral fertilisers or poultry manure.

The demonstrations were discontinued due to problems securing match funding (65%), scaling-up costs for infrastructure, the requirement for private investment, occupant land ownership issues making future investment an unrealistic option and the physical distance between the research institute (Kumasi) and the demonstrations in Accra.

## Monitoring the Change / Transitioning Process

The Accra Learning Alliance journey was documented by the LA facilitator in order to monitor the outcomes of the LA. Regular process documentation included progress reports on activities of the LA such as the outcomes of workshops and meetings undertaken. Activities were photographed and videos and reports produced from workshops. This enabled effective dissemination of information, and was an effective empowerment tool for the stakeholders. A brochure was distributed to stakeholders at LA and other meetings. Briefing notes for policy makers were developed after the visioning workshop. This was circulated among key stakeholders including ministers and members of parliament. City assessments also monitored LA progress by capturing and organising the transitioning process.

## Transition Management strengths

From a transition management perspective the transitioning strengths developed in Accra during the SWITCH project include **developing the transition arena** through good facilitation of the Learning Alliance at the **strategic level**. Experiences with the organisation of permanent support for IUWM issues are all transitioning management strengths that have been developed at the **tactical level**. This included an ongoing process of agenda setting, coalition building, negotiating, networking, media engagement, capacity building and reflection for lesson learning.

The experience gained at the **operational level** in experimenting with innovative methodologies has resulted in valuable lessons being learned. Although at first this may not seem like a gain, the lessons learned from the attempts made are available for the next round of project building and implementation.

## Futures and Transition Pathways

Accra has complex issues of population growth, spread of slum areas, limited financial and institutional capacity and social behaviours. The city assessment highlights a need not only to look at future demands and drivers but also to have some well defined “easy wins” in a short-term plan that will enable up-scaling. This will give credibility and recognition to sustainable solutions.

### LA Member - Ministry of Water Resources

“The Water Directorate was formed to provide central policy and manage the project and international donor interface. As informal settlements continued to grow it started to become obvious that there was a need for sustainable water management through the sector, with proper policies being put in place. **SWITCH** came along just at the point that they were ready for this concept. The Ministry gave its “blessing” and the LA was formed as a multi-stakeholder Platform. So **SWITCH** really did enable the Assemblies to see that Integrated Water management was the most appropriate to dealing with the issue at the Municipal level. The **SWITCH** Intervention was a very welcome move, and as the Directorate takes on more and more responsibility for the coordination of and gathering of information, then the work that has been done on developing the RIDA and Strategic Plan will be very useful to the whole water sector”

Transitioning from the current situation towards this vision will require a solid strategic plan that must take into account the different scenarios related to external factors such as population growth, economic growth and the raw water situation. Reflection on the past and current limitations and successes described in the previous sections will help to improve the quality of future decision making in Accra.



## Recommendations in the Strategic Directions Report

We believe that the recommendations provided in the Strategic Directions Report should form the building blocks to achieve the vision.

### Water Supply

The main threat to water supply is mismanagement of the system. The level of non-revenue water is high and there are constant interruptions. While treatment capacity is almost sufficient for supplying the present (2010) population, this must be expanded to deal with future growth. A service is also required for high density and unplanned urban areas which are unsuitable for household connections. Promising approaches include:

- Community managed distribution of utility bulk supplies.
- Registration and regulation of alternative providers.

### Sanitation

There are virtually no sanitation services in Accra and there is an urgent need for dignified and affordable access to sanitation. In addition, long term solution(s) to liquid waste need to be identified urgently if the vision is to be achieved by 2030. Promising approaches include:

- Privately managed public latrines in the short and medium term
- Rehabilitation of sludge treatment and disposal facilities

### Stormwater Drainage

Many areas of Accra are prone to flooding, which is exacerbated by the increase of paved areas without an increase in drainage capacity, building in water ways and by blockage of existing drainage capacity due to poor solid waste management. Institutionally the sector is fragmented, with overlapping and contradictory areas of responsibility. Planning is poor. In order to improve this situation, the following is suggested:

- Clearly delineate boundaries and responsibilities.
- Create an integrated planning framework.
- Enforce existing laws and bye-laws.

## The extent of the change which occurred

Accra's greatest challenge remains providing water and managing the service for an expanding population. Overall a transformative change to integrated thinking for urban water management has not yet occurred but **SWITCH** encouraged a transition arena where stakeholders now understand water issues and will consider IUWM options. Sustaining this mindset will probably be the biggest challenge for decision makers. The recommendations in the Strategic Directions Report should provide the basis for the 2030 vision.

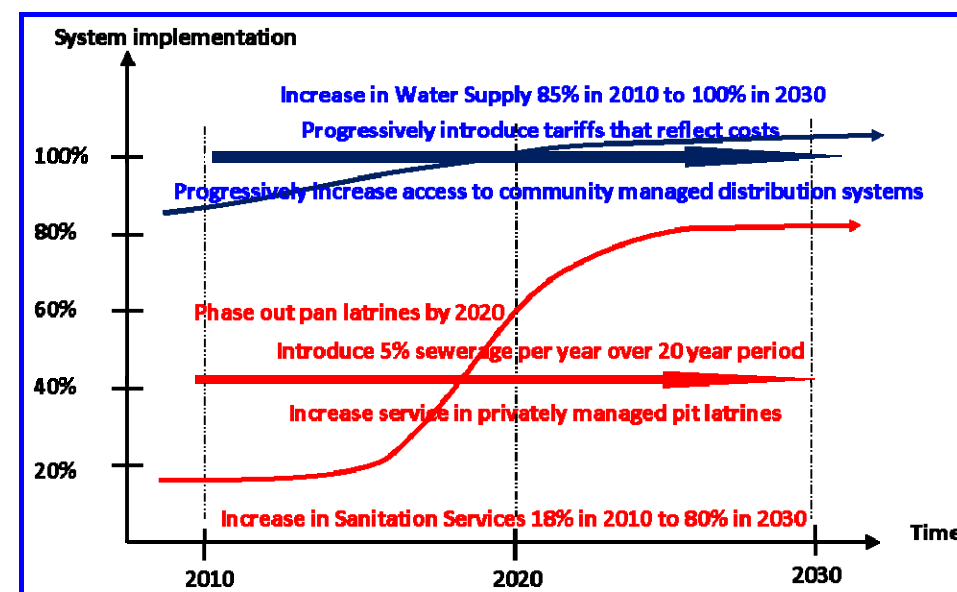

Accra Potential Future Transition Pathways to 2030

The transitions diagram for Accra shows the key actions for the city;

- Increase the provision of water supply.
- Phase out private pan latrines.
- Construct 5% sewerage per year over a 20 year period.

## Transitioning Urban Water in Alexandria



Alexandria – Pearl of the Sea

“Alexandria is a good example of a city of the future. It is the second largest city in Egypt which urgently needs integrated water management. Through **SWITCH** we have achieved changes in decision making and we are making changes towards real integrated water management.”

Quote from a LA member/ researcher (2010)

## SWITCH and the present in Alexandria

**Population:** 4 million (6 million in summer). Egypt's second city.

**Area:** (Region – 2,120 km<sup>2</sup>). 70km of coastline.

**Climate:** North African Mediterranean: Relatively temperate summers (Ave 31°C), cool winters (coldest month 18°C), Annual rainfall 200mm.

**Water resources:** River Nile is the only source of water in Egypt.

**Water systems:** Most of the city is covered with potable water supply networks; Sewerage coverage – 80%. Sewage treatment for 80% (at least primary)%.

**Water related issues and challenges:** Satisfying increasing water demand • Developing local water resources • Collecting and separating and reusing stormwater • Groundwater use • Grey water recycling • Reuse of treated wastewater • Water demand management • Exploring other non-conventional water resources such as sea water or brackish groundwater desalination • Protecting water ways and water bodies from pollution.

**Learning Alliance:** Learning Alliance formed • Limited success due to lack of ‘thinking out of the box’. Two visions for water and sanitation developed.

**Water Resources Management:** Some sewerage and surface water to Lake Maryut or Mediterranean • Nile water allocation always problematic • Seam level rise makes Alexandria a very vulnerable city.

**Initiatives to deal with these risks:** Demonstration Project at fisherman's village.

### Overview of issues influencing Water Services

#### Alexandria Past

Alexandria is a very ancient city which has periodically been reclaimed by the sea. Records from 45BC show that a canal from the River Nile at Shedia supplied the city with water. The city was almost abandoned twice in its history, once due to volcanic activity and the second due to the development of an alternative port close by.

#### Governance

The city government is very centralised and autocratic with all legislation and policies being directed from Cairo. The only potable water source for Egypt is the River Nile and as a consequence, the national water development plan has great importance and water infrastructure issues influence most decisions. The Alexandria master plan must cope with considerable population fluctuation associated with tourism.

The responsibilities for water and sanitation are separate by edict from the Egyptian government making communication between the two authorities problematic. This also reduces the opportunities and incentives for integrated thinking. The city has nine low-income, peri-urban areas that are poorly served with both water and sanitation services although there are city and governorate level plans for extending services to these areas.

#### Current Water Issues

In addition to supplying the city population, water is also supplied to neighboring areas outside the city. The city is trying to withdraw from these arrangements to leave it with more water. Unaccounted for water is currently at the high level of 37% and leakage detection/ repair is an urgent priority. Since all water originates from the Nile, the lack of wastewater treatment causes a deterioration in river quality. This also makes improved sewage treatment a priority and the benefits of integrated thinking are becoming more apparent.

### SWITCH in Alexandria – Developing the Transition Arena

#### Alexandria Learning Alliance

The Learning Alliance made a significant contribution to the development of integrated thinking in Alexandria. The role of the LA became well understood and there was serious engagement and commitment between meetings. The international exposure and the chance of continuous engagement after **SWITCH** was significant in encouraging the actors to participate in the LA. However, continuous delays dampened enthusiasm.

#### SWITCH Intervention

Co-ordinated plans for the surface water catchment and sewerage network are under development. This will facilitate treatment and potential reuse of water. The water balance (and flux) has been provisionally examined but this study is in its early stages and the scenarios to be examined need to be targeted more towards dealing with the real issues of the existing situation and the potential options.

#### Strategic Water Studies

The **SWITCH** Learning Alliance was represented in the strategic studies undertaken. The studies included: waste water reuse potential, ground water potential, water demand management, institutional mapping, financial sustainability, desalination, and urban water modeling. The studies were launched, discussed, and evaluated in three workshops where LA members participated.

#### Integrated Urban Water Management Plan

The results from the strategic studies were major inputs for the plan. All existing plans were studied so that the IUWM could be aligned with them (NWRP, Alexandria Water and Wastewater Master plan 2037). An assessment of Nile water availability in 2037 was also carried out to determine the future degree of dependence on unconventional water resources.

The strategic studies were essential for making **SWITCH** more credible within Alexandria.

TABLE ( 16) ALEXANDRIA STRATEGY PLANNING											
CURRENT SITUATION				STRATEGIC HORIZON FOR DRINKING WATER - 2037							
Year 2009				Pessimistic				Optimistic		Realistic	
Total Water Produced	947343750			1753				584		1006	
Total Water Sold	606300000			1122				561		805	
Population	4670000			8640000				7650000		8300000	
Category	Consumption		Consumption		Volume	Consumption		Volumes	Consumption		Volumes
	%	L/C/D	%	L/C/D	m.m3/year	%	L/C/D	m.m3/year	%	L/C/D	m.m3/year
						Red.			Red.		
Domestic	61.16	218	61.16	218	686	50	109	343	24	165	500
Industrial	11.20	40	11.20	40	126	50	20	63	25	30	91
Commercial	11.71	42	11.71	42	132	50	21	66	48	21.6	65
Investment	6.51	23	6.51	23	73	50	12	37	5	22	67
Governmental	6.73	24	6.73	24	75	50	12	38	8	22	67
Harbour	0.03	0	0.03	0.1	0	50	0.1	0.2	0	0.1	0
Discounted Units	0.86	3	0.86	3	9.8	50	2	5	48	1.6	5
Exported (Behira)	1.80	6	1.80	6	20	50	3	10	48	3.3	10
Sum W/O losses	100	356	100	356	1122		178	561		266	805
UFW , %	36		36			15			20		
Sum ALL INCL UFW		556		556	1753		209	584		332	1006
UFW	36	200	36	200.08	631	15	31	88	20	66	201

### Three scenarios for drinking water production and consumption

#### Evaluation of different cost recovery schemes

The **SWITCH** tool City Water Economics (CWE) was used to study two aspects of the economics of operating the water system in Alexandria:

- The preliminary assessment of alternative tariff schemes for improving cost recovery in potable water supply provision, and;
- The evaluation of incentives offered by current and potential pricing policies for the installation of water saving appliances in households.

Two studies were developed by SWITCH to support the Alexandria Strategic Planning process, the Water Demand Management Study, and the Study on “Whole of System Modeling and Decision Support”.



The assessment of the tariff scheme through CWE showed that:

- Current revenues from residential tariffs correspond only to 36% of the total annual operational and maintenance costs of AWCO, whereas residential consumption accounts for about 60%;
- The majority of consumers (~87%) use greater than 30 m<sup>3</sup> per household per month and the current tariff provides limited incentive for water conservation.

The water demand management study for Alexandria examined alternatives to support this intervention. It was estimated that the average cost per household would amount to 72 EGP. The strategy studied involved financial and technical support for the purchase, installation and maintenance of water saving devices in houses. This support would be recovered through an additional charge on the water bill for the households concerned.

In all cases analysed, the payback period was less than 1 year, implying that (a) subsidies are not required even without tariff reforms, and; (b) a tariff reform, combined with information and awareness campaigns could yield results similar to the strategy proposed by AWCO.

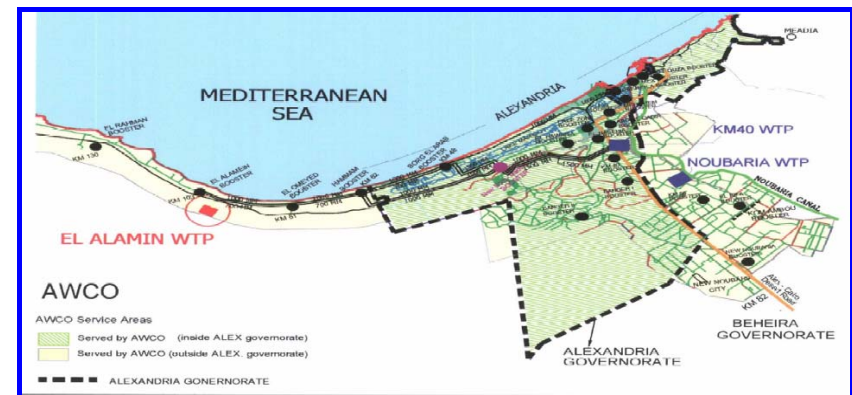

Key Water Features

### Transitioning in Alexandria

The governorate is very interested in any form of strategic water plan delivered and **SWITCH** in Alexandria was very timely, giving a 'window of opportunity' that should result in an important strategic plan for the city. During the five years of the **SWITCH** project, transition management cycle activities in Alexandria occurred primarily at the tactical and strategic levels. Although planned, activities at the operational level (experimenting / demonstrations) were very slow to get underway.

A major hold-up of rolling out transition experiments in the city was the length of time that it took to build a stable and effective transition arena that consisted of suitably diverse water / planning sector actors. Although Alexandria has one of the oldest water systems in the world and much water information and data exist, it was extremely hard to access. This delayed the baseline assessment of the existing situation and the subsequent development of a vision and strategic plan.

Key Transition Management Cycle strengths during the **SWITCH** round of transitioning included:

- A transition arena was created.
- A transition agenda was developed.
- Documentation techniques for baseline assessment using the RIDA framework were developed.
- Evaluation and monitoring processes were put in place.

### A Water Vision for Alexandria for 2037

Alexandria's LA team started with two separate visions for water supply and sanitation. One of the successes of the SWITCH process was to develop a joint vision which envisaged a proud water city where available water resources are managed in an integrated manner, with the participation of all citizens, and are used effectively for development within a framework of environmental sustainability. It will also be one where all citizens have access to high quality (meeting national norms), reliable, sustainable, and affordable water and sanitation services and benefit from a clean and healthy environment.

#### Alexandria Joint Water Vision for 2037

A clean and well managed aquatic environment.  
Provided by a renewed and upgraded network  
Full separation of sanitation and (agricultural and rainwater) drainage networks  
Treatment and reuse of agricultural, industrial, and domestic wastewater  
Agricultural water use managed as part of a city wide water management plan



Ranking scenarios



A green park in Alexandria

## The Water Vision for Water Supply

Institutionally, water and sanitation provision are quite separate in Alexandria and the separate visions are much more detailed than the joint vision. However, the greater detail does not necessarily mean they are more likely to be achieved.

The vision for water demand management in Alexandria City in the future (2037) is to keep and maintain a sustainable urban water supply system through:

- All citizens of Alexandria, visitors and tourists to Alexandria have access to high quality, sustainable and affordable water and sanitation services.
- Water resources are managed perfectly and in an integrated manner.
- There is a clean and healthy environment in Alexandria region.
- Per capita of drinking water is minimized to comply with and match standards. AWCO is in full control of managing water losses.
- An integrated policy management for re-using treated wastewater is applied.
- Application of appropriate technologies and methods in agriculture to minimize agricultural water consumption.
- Reliance on desalination is applied specially in the North Coast.
- Separate the network for irrigating green areas, parks and gardens. Supply water to these areas through a separate network.
- Use water saving devices and tools in all sectors.
- Citizen awareness building programmes to encourage reduction in water consumption patterns and solutions on how to achieve set targets.

## The Water Vision for Sanitation

To fulfill its mission and vision, ASDCO plans to provide full sanitary services to meet the current and future (2037) needs of Alexandria through:

- Public health will be protected by the effective sustainable collection, treatment and disposal of wastewater.
- Public and infrastructure safety will be ensured by the effective control and suitable reuse of storm waters.
- Public waterways protected by complete reuse of better treated wastewater.
- The environment of the citizens of Alexandria will be protected by appropriate disposal/reuse of wastewater and storm waters and by the implementation of environmentally approved construction and operating procedures.
- Foster economic growth by improving water quality in Alexandria's waterbodies.
- ASDCO will be a financially self-sustaining, empowered and independent company.
- ASDCO will be conducted by well-trained, motivated, professional and experienced staff.

## The extent of the change which occurred

Unfortunately **SWITCH** progress in Alexandria was less than was hoped. We consider that this is as much to do with extremely long established and rigid institutions which are set up to restrict integration and innovation. This is highlighted by the two sectors preparing the separate visions.

**Scenario Planning for 2037**

**Pessimistic Scenario** - Explosive population growth with population reaching 8.64 million. Nile water availability of Nile is 40 % less than in 2009, rainfall is decreasing, domestic consumption of drinking water remains at the current value, the total water consumption for different activities is 1753 m.m<sup>3</sup>/year. There is increased risks of flooding due to sea levels rising. The economy is weak with high energy costs and wastewater systems are not adequately protected from increasing saline intrusion. Attempts are being made to minimise the effects of wastewater effluent on the River Nile by improving quality control and management of sewerage systems, reusing effluent for agricultural and non-edible industries and implementing decentralised wastewater systems.

**Optimistic Scenario** - Population growth is low, reaching 7.65 million. The economy is dynamic and fast growing. The Nile water allocation is guaranteed and exceeds the current allocation. Sea levels are not rising, there is increased rainfall, domestic consumption of drinking water is reduced by half and the total water consumption for different activities is 584 m.m<sup>3</sup>/year. There are adequate financial resources with low energy costs due to using other methods and sources of energy (solar energy, wind etc). Wastewater systems have been upgraded and extended with increasing use of tertiary treatment and effluent reuse for agricultural purposes resulting in improvements to the aquatic environment.

**Realistic Scenario** - Population is growing reasonably, reaching 8.3 million and the national allocation of Nile water is the same as in 2009 with the economy growing normally. The domestic consumption for drinking water is reduced by 25% and the total water consumption for different activities is 1006 m.m<sup>3</sup>/year. Rising sea levels are beginning to threaten some parts of the city. Energy costs are reducing due to the reduction of energy consumption and the use of clean sources of electricity generation. There is increasing cooperation with local and international funding bodies for environmental solutions. These will alleviate the impacts of increased tourism, commercial and industrial activities on primary treated effluent

and raw sewage through upgrading the wastewater infrastructure and implementing treated waste water reuse technologies.

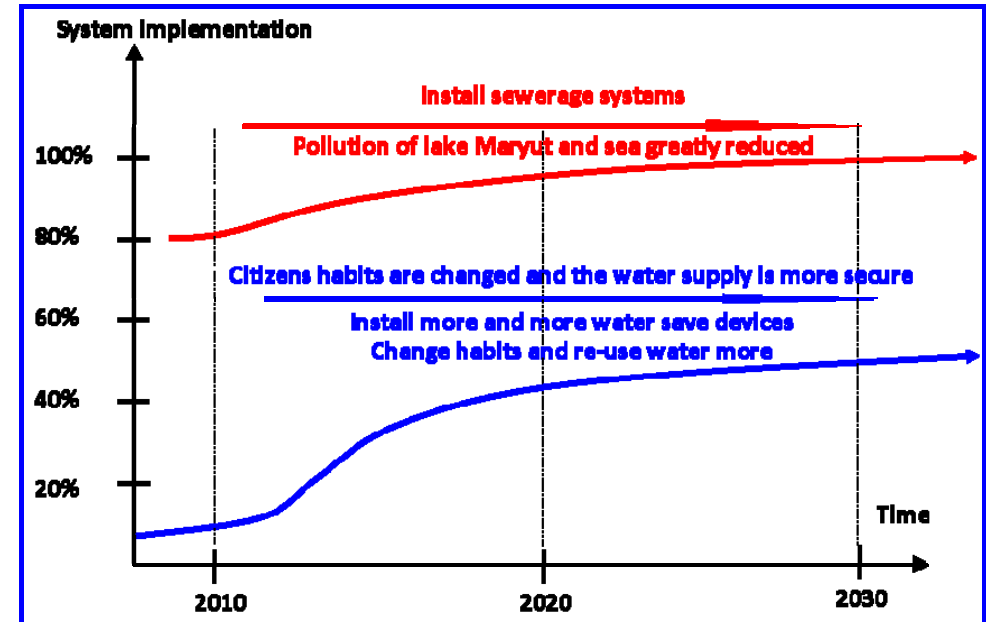

**Potential Future Transition Pathways in Alexandria to 2037**

The transitions diagram for Alexandria shows the key integrated water management actions for the city;

- New sewerage systems have been installed to reduce the amount of pollution in Lake Maryut and the Mediterranean sea.
- Water saving devices have been installed in many households.
- The habits of citizens have been modified resulting in considerable water savings per household.

## Transitioning Urban Water in Łódź



### Łódź, a city whose name means boat, is searching for its rivers

The City of Łódź is the second largest in Poland with approximately 760,000 inhabitants. The history of Łódź is closely linked with the textile industry, which developed in the 19th century in part because of the area's excellent surface and groundwater resources. Most factories had their own wells, so there was no demand for a water system. By the early 21<sup>st</sup> century much of the industry had disappeared leaving a legacy of polluted and culverted watercourses and a poor water supply system.

The water shortage in the 1950's triggered a shock. It became clear that public water supplies were completely inadequate and that change was needed. The chronic pollution of rivers highlighted the absence of pollution prevention measures. The uptake of environmentalism became a macro driver that was complemented by the need to comply with the EU Water Framework Directive.

## SWITCH and the present in Łódź

**Population:** 760,000. Poland's second largest city and main city in western Poland.

**Area:** 293,25 km<sup>2</sup>.

**Climate:** Temperate - continental. Annual precipitation: 519.6mm. Mean annual temperature: max 20-27°C, min 3 to -8°C.

**Water resources:** High hydrological stress on rivers and habitats simplification lowers ecological potential and water quality.

**Water systems:** Water supply coverage near 100%; Sewerage 91%.

**Water related issues and challenges:** Adaptation of city catchments and rivers for interception of large storm water and pollution loads • comprehensive wastewater treatment plant management including alternatives for sewage sludge utilisation • biomass production • river rehabilitation • Increased quality of life for city inhabitants • rehabilitation of contamination and culverted watercourses from industrial past.

**Learning Alliance:** LA has wide representation of stakeholders • City Office, service providers, research institutes, developers and designers, society groups' representatives, local newspaper. National/Regional • Voivodship – four separate organisations, Regional TV. • Neighborhood: Schools, NGOs.

**Water Resources Management:** Pollution in the River Ner during rainy weather (stormwater inflow lowers WWTP efficiency). Heavily modified streams and catchments. Need to increase stormwater retention in landscape. Comprehensive wastewater treatment plant management required to address issues of sewage sludge, biomass production, and river rehabilitation.

**Initiatives to deal with these risks:** Improved understanding of hydrology and ecology of the city (ecohydrology approach) • demonstrations and innovations • linking stakeholders to research • public awareness activities.

The 18 streams of the Sokołówka river have now become the symbol of the environmental improvements addressed by **SWITCH**.



Water Service Provision Timeline 1901 - 2004

Year	Event	Factor/ Outcome	Organisation Change	Actors
1901	Strong public pressure for a WaSN	Growing population (now 320,000); sanitary conditions critical	Mayor invites William H Lindley to design Łódź WaSN	Public, Mayor, Engineer
1909	Sources proposed using 50km away	Lack of suitable water resources near Łódź; Łódź's topography	Proposed design	WaSN Engineer
1918-1925	Project plans are re-examined and set in motion	Public pressure; new political environment	WaSN construction begins 1925 Municipal WaS unit set up	
c. 1950	Municipal Co. taken over by voivodship	Most municipal services nationalised	Nationalisation	Voivodship
1952	New 50km surface water supply line commissioned	Dramatic water shortages in Łódź (rationing since 1950)	New supply line (completed 1955)	Voivodship
1968-1977	22km long artificial lake developed	Increase supply and ensure year-round supply	Supply increased and secured	Voivodship
1976	Construction of WWTP begins	Widespread environmental pollution from wastewater	Financial constraints mean not complete by 1990	Voivodship
1990-2000	50% decline in water consumption	75% industry decline; greater efficiency; meters, higher prices	Less water needed; use of surface water & costs reduced	Industry, consumers, company
1994	Phase I WWTP completed	Finance provided by city, company and National Environment Fund		City/Mayor/ NELF
2004	Final phase of WWTP starts	Continuing pollution issues; EU directive (UWWT); EU finance	WWTP to be completed to EU standards by 2006	City/Mayor
2007	Final phase of WWTP complete	Improved water quality in the Ner river ; Need to address stormwater issues	One of the most modern WWTP in Europe	City/Mayor

Transition Pathways for Water Service Delivery

SWITCH transitions became focused on the following issues:

1. Improved understanding of the links between hydrological and ecological processes with data collection and modeling.
2. Demonstrations based on ecohydrology principles and a system approach.
3. Linking city stakeholders to demand-led research at all stages through the LA.
4. Public awareness activities leading to wider sense of ownership.

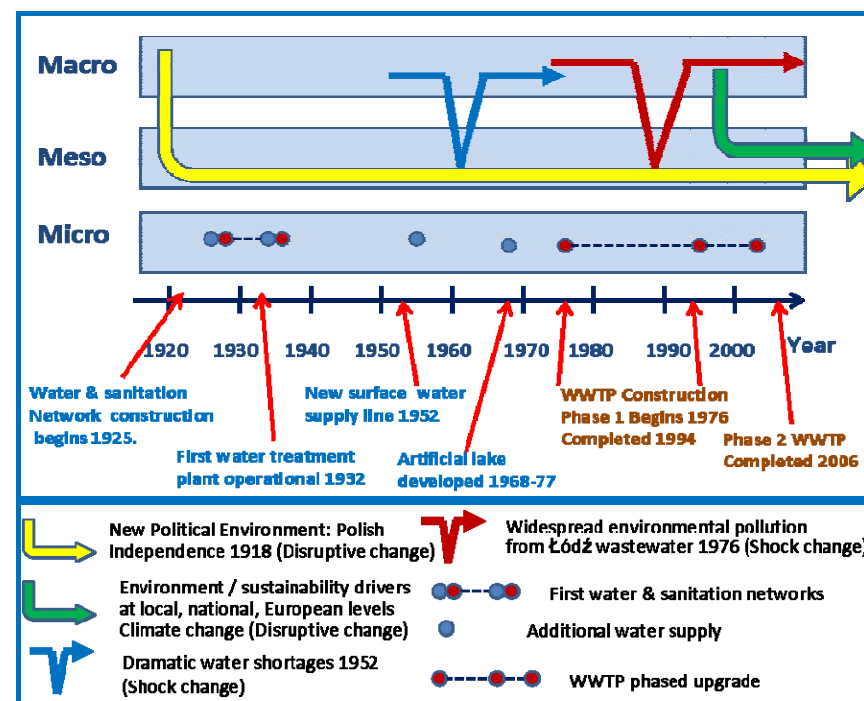

Łódź 'Historical' Transition Pathways 1925 - 2000

## SWITCH in Łódź – Developing the Transition Arena

The **SWITCH** project moved Łódź forward by embedding a more integrated and holistic approach to managing urban water systems. The strengths of the existing IUWM strategies were enhanced by including strong participatory stakeholder and experimental strategies. Łódź embraced the **SWITCH** philosophy and explored new approaches such as visioning and strategic planning thus adding to their existing transitioning strengths. These strengths included developing a strong transition arena through the Learning Alliance. A number of methodologies were up-scaled towards the end of **SWITCH** including experimentation, project building & implementation, and innovation techniques. The figure on page 85 illustrates the transition pathways taken by Łódź during the ‘present’ phase, which included **SWITCH** intervention.

### Resources Management

Green areas - river valleys are the ‘green lungs’ of Łódź. Ecological biotechnologies and the population’s deep ecological awareness has contributed to an exceptionally high quality of life. Łódź is a leading centre for innovation, education and best practice implementation in Poland. An ecohydrological approach has contributed to mitigating the issues in the Sokołowka River and increasing the quality of life and environmental health by improving flood protection and access to open water. This is very much part of the vision Lodz 2038 “Lodz uses water wisely”, developed in SWITCH.

### Learning Alliance Members

The LA includes national, regional and local members. **City Level** City of Łódź Office, service providers (WWTP, Lodz Waterworks, Lodz Infrastructure Company), research institutes, developers and designers, society groups’ representatives, local newspaper. At the **National / Regional Level**: Voivodship Offices - Spatial Planning, Environmental Protection, Regional Boards for Water Management, Regional TV. **Neighborhood Level**: Primary and secondary schools, Housing Estate Councils, NGOs.



## Transition Experiments – Strategic Niche Management

**SWITCH** in Łódź aimed to introduce a package of measures for IUWM to reduce flood peak flows and levels of pollution in the rivers and to improve the quality of the urban environment. This is being achieved by making Łódź’s hidden rivers more accessible and attractive. Reduced flows from flash floods will have benefits for wastewater treatment and reduce stormwater pollution, as well as protecting people and property. Lower pollution levels in the watercourses will make water safe for recreational use and improve the riverine ecology ensuring that targets set out in the EU Water Framework Directive are met. Making Łódź’s rivers more visible and restoring channels to more natural conditions is supporting city revitalization efforts and contributing to sustainable development.

The focus and scope of these measures changed as the project moved towards implementation and the priorities of stakeholders emerged. The research undertaken fell under the following headings:

- River restoration following ecohydrology principles.
- Utilising sewage sludge as a resource for bioenergy production.
- Sustainable city’s river corridors and green areas planning (Blue-Green Network Concept).
- Implementing stormwater BMPs.

The City of Łódź Office participated in all **SWITCH** learning alliance meetings and was a key player in the niche experiments and implementation. Through the demonstration projects on the Sokołowka River the company tested new approaches to improving water quality and improving the urban environment and now wants to replicate river restoration activities across the 18 other rivers in the city. Unfortunately the city lacks financial resources and capacity. Developers don’t want to pay: in fact they try to lever investments from the city, and it is hard to attract investors.

### Testing principles through pilots

Innovative methodologies for integrated and sustainable improvements in urban water management were tested in demonstrations involving both researchers and research users. **SWITCH** was important in helping the city put practical innovations into use. The initial demo sites generated new plans and spin-off activities related to river restoration using the concepts and designs piloted in **SWITCH**.

There were two major foci of the demonstration initiatives, the first being a rehabilitation project of the Sokołówka River valley. The second focus was a demonstration site to test the feasibility of the reuse of sewage sludge in the cultivation of willow as an energy crop at the WWTP. Both were carried out by the City Department of Infrastructure advised by the University of Łódź.

#### River restoration in the Sokołówka river valley

The demonstration activities included construction of two new reservoirs on the river and ecohydrological adaptation of one of the existing reservoirs. An inefficient detention pond constructed before SWITCH has been reconstructed to an innovative system (Multi Chamber Sedimentation Biofiltration System). A conceptual and technical plan for river rehabilitation was developed. As a spin-off, two other reservoirs were constructed by the City Office. A developer in the Sokołówka River valley contacted the LA and implemented stormwater BMPs.

#### Closing the nutrient cycle: using sewage sludge to grow energy crops

The Łódź wastewater treatment plant receives and treats all sewage from the city before discharging treated water into the Ner River and disposing of the remaining sludge to landfill. Pilot plantations of willow were cultivated by the operating company (WWTP) on municipal land next to their wastewater treatment plant using the sewage sludge as a fertiliser. It would be impossible for the plant to meet targets for heavy metal contamination without action being taken upstream by these stakeholders.

**SWITCH** recognised that there was an important need to improve communication, trust and collaboration between the different agencies involved. This demo was a good example of close co-operation between the university and the city stakeholders. The energy generated from the willow plantations started to be used within the lifetime of **SWITCH**. More research on costs and management options is needed. Methods for using more sludge are currently being tested. Research into the composted sludge was the basis of a four year PhD studentship. In addition to the scientific studies, there was close collaboration with staff at the WWTP, the municipal office, private companies and fellow citizens of Łódź.

#### Interventions logic

There were four key aspects of the **SWITCH** project in Łódź:

*Improved understanding of hydrological processes will lead to better comprehension of the role of rivers and better interventions*

Considerable effort and resources were committed to surveys, monitoring and other research to provide data and understand fundamental ecological and hydrological processes.

*Demonstrations based on ecohydrology principles and a systems approach will lead to more effective and sustainable solutions*

**SWITCH** encouraged the better design of urban water systems. Alternative designs were developed jointly by the university and city.

*Linking city stakeholders to research at all stages*

The project team thought about the use of research and scaling up the technologies from the outset. The LA created the conditions for productive stakeholder dialogue on goals, problems and solutions to deliver and share results more quickly than is normal practice.

*Public awareness activities will lead to a wider sense of ownership*

To build a wider alliance beyond water professionals and immediate stakeholders – the **SWITCH** team in Łódź undertook awareness raising activities. These included engaging the youth of Łódź to raise

their awareness of environmental issues, communicating through the radio and newspapers. A website provided a central source of information on the project. (<http://switchłódź.wordpress.com/>).

## Present Pathways

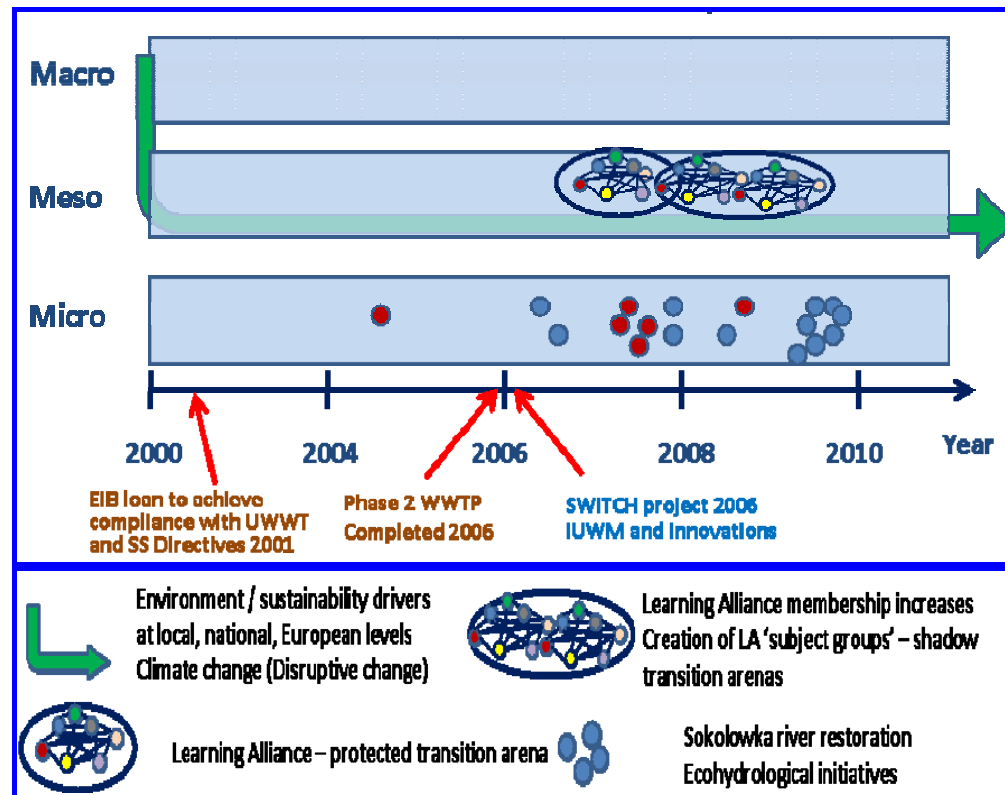

Łódź 'Present' Transition Pathways 2000 - 2010

## Łódź Transitioning Strengths

We consider that the successful Learning Alliance in Łódź is a particular success for SWITCH. Key strengths were:

- The transition arena strengthened during SWITCH with key players now in place.
- Transition experiments well under way.
- Strong transition agenda with IUWM focus.
- Process documentation writing strengthened during SWITCH.
- Evaluation process and lesson learning from experimentation underway.
- Dynamic up-scaling and spin-offs by decision makers and public (bottom-up activities).

Rolling out innovations across the city rivers is now underway in the next round of transitioning.

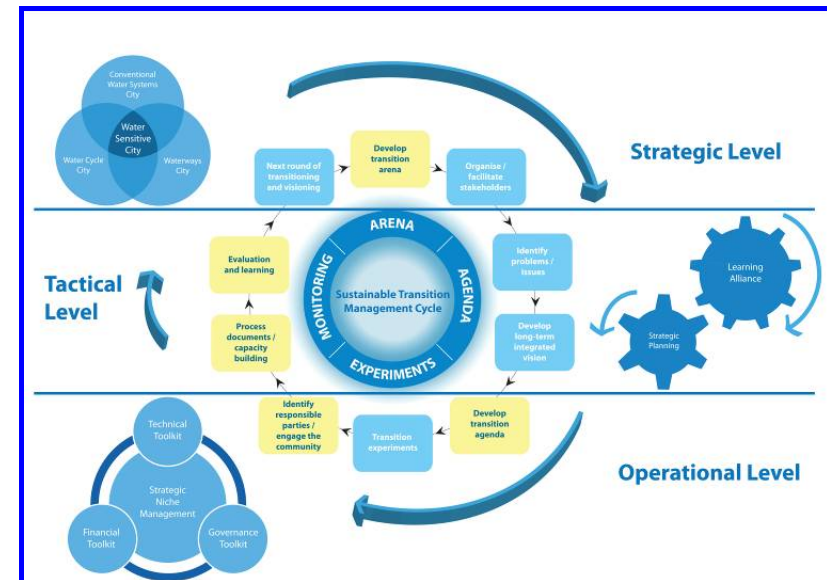

### Scenario Planning for 2038

The following visions for Łódź were developed during SWITCH.

**Scenario I (Very Pessimistic)** - The economy is stagnant owing to worldwide economic recessions and poor performance of the Polish economy. The country is one of the poorest in Europe with low tax revenues and little external funding for investment for improving infrastructure. Institutions dealing with water management at a city level are highly fragmented and there are no plans to improve the overall performance of water systems. Slow responses to climate change challenges and an overall deterioration of the city's urban environment with the level of water and sanitation service becoming unacceptable.

**Scenario II (Pessimistic)** - The economy is stagnant owing to worldwide recession and poor performance of the Polish economy. The country is one of the poorest in Europe with low tax revenues and little external funding for investment. However, strong leadership and professionalism within institutions dealing with water management leads to improved sharing of information and coordination and an integrated plan is developed and implemented where water is used wisely to improve the environment. Shortage of tax revenues has limited the scope for major investments needed for effective responses to climate change challenges and lack of investment funding has resulted in action by community-based groups which has not been able to impact on all challenges facing the city.

**Scenario III (Realistic)** - The Polish economy develops steadily to become the largest in eastern and central Europe and many young people return to the city owing to the better wages and prospects. The higher tax revenues can be invested in infrastructure improvements. Institutions dealing with water management at a city level are highly fragmented and investment addressing climate change challenges is poorly targeted. Individuals and urban "landcare" groups have become a strong political voice; however the ability of local action to address major problems is quite limited resulting in a growing gap between the rich and the poor.

**Scenario IV (Optimistic)** - The Polish economy develops steadily to become the largest in central Europe. Higher tax revenues invested in infrastructure improvements. Strong leadership and professionalism leads to improved sharing of information and coordination. Water is used wisely to improve the environment with an effective response to climate change challenges. Environmentally sound water and sanitation plans are aligned across all sectors that benefit the city's inhabitants and ecosystems. Local action and innovative city governance has resulted in Łódź becoming IUWM leaders that are in high demand around the globe.

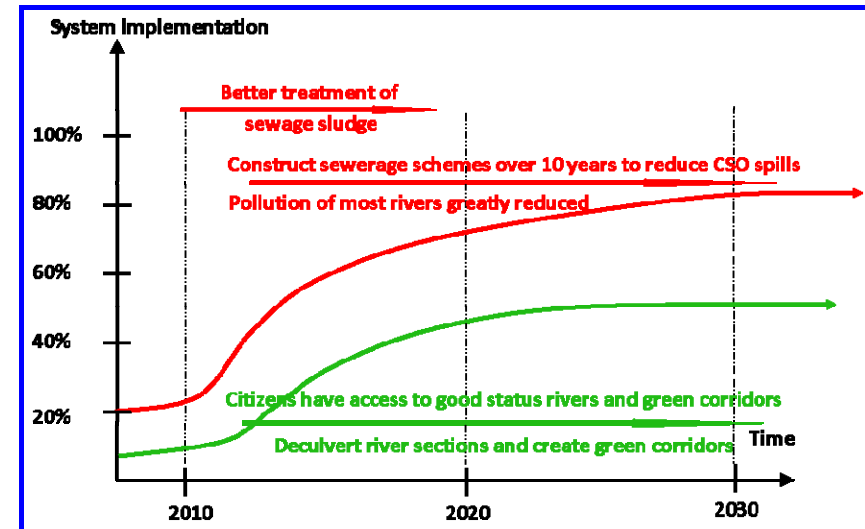

Possible future pathways in Łódź

The transitions diagram for Łódź shows the key integrated water management actions for the city;

- Reuse of sewage sludge as a resource.
- Improvement of stormwater management to reduce flooding and river pollution.
- Better access to green river corridors (Blue-Green Network).

## Transitioning Urban Water in Belo Horizonte



**Belo Horizonte – Beautiful Horizon**

Belo Horizonte (meaning Beautiful Horizon) was established 1894-1897 as the new capital of Minas Gerais state. It was the first modern 'planned' city in Brazil. Much sub-urban space was dedicated to green space as a transition between urban and the natural environment and to contain growth.

## SWITCH and the present in Belo Horizonte

**Belo Horizonte (BH)** is the capital of the State of Minas Gerais, which has the third largest state economy in Brazil and the population is nearing saturation level.

**Population:** 2.4 million (3.9 million in metropolitan area).

**Area:** 330 km<sup>2</sup> (9,179 km<sup>2</sup> metropolitan area).

**Climate:** Tropical at altitude, yearly average temperature 9°C - 35°C. Annual precipitation: 1,500 mm.

**Water resources:** Surface water sources. High standards in terms of operation and water quality

**Water systems:** Water supply - 99.7%; sewerage coverage - 92%.

**Water related issues and challenges:** Heavily polluted receiving bodies due to lack of interceptors and illicit connections into stormwater networks • Health risks due to direct human contact with polluted water • Floods cause property damage and loss of life.

**Learning Alliance:** LA (BEHLA) is oriented towards integrated urban water management issues • The LA piloted the DRENURBS programme.

**Water Resources Management:** Up to the 1990's storm water management was a conventional and simplified approach with a focus on structural solutions • 200 km of lined channels • over 700 km of perennial creeks • Oversimplified modelling: Rational method; Permanent uniform flow • Lack of hydrologic data • Lack of planning.

**Initiatives to deal with these risks:** Storm water strategic plan (on-going) • Water supply and sanitation plan (on-going) • Environmental Sanitation Municipal Board • DRENURBS program.

Water Service Provision Timeline 1950's - 2006

Year	Event/ Org change	Factor/ Outcome	Actors
1950's	New neighborhoods developed by architect Oscar Niemeyer	Population boom and requirement for flood control and landscape enhancement. Lake Pampulha	Mayor / City
1970's and 1980's	Investment in stormwater infrastructure to improve water quality	Intense urban growth Culverting and river modification	Municipal / City
1971	PLANASA – National Water Supply and Sanitation Plan. Creation of COPASA, a mixed (public/private) municipal co/ for sanitation services	Transfer of WSS services to COPASA (state company)	Federal / Municipal
1993	Participatory Budgeting (OP) programme implemented	Desire to enforce democratisation efforts. Democracy strengthened with citizen chosen projects	Municipal / City
1990 - mid 1990's	Period of hyperinflation (as much as 25%). Creation of COMUSA a Municipal sanitation council	Rapid urban growth continues. Flooding continues and illegal connections cause gross pollution	Federal / Municipal / City
1995	Investment in urban drainage drives a shift towards more environmentally sustainable practices / solutions (BMPs / SUDS)	Need to improve drainage effluent quality and a desire to 'naturalise' streams. Waste water interceptor and treatment programme River restoration, BMP / SUDS pilots combined with parks and recreation areas	Municipal / City
2000	End of the Brazilian concessionaire. A more complex relational structure developed for WSS	Intended for better integration of all urban services. Shared management model for WSS – state and municipality own COPASA, decision sharing for COMUSA	Federal / Municipal / City
2006	Federal Law 9433/97	Need for risk management in the water sector at all scales. Federal legislation for environmental legislation and the water resources management law	Federal
2006	Development of municipal strategic plans	Municipal sanitation and stormwater master-plans	Municipal
2006	DRENURBS	Demo projects in BMP/SUDS	Learning Alliance

Transition Pathways Towards IUWM

The **SWITCH** approach in Belo Horizonte called for more integrated and inter-disciplinary research than had hitherto been undertaken. In addition, the project sought to engage the relevant stakeholders and establish links between research providers, knowledge managers and research users through the Learning Alliance. **SWITCH** started work in the second half of 2006 with the aim of further helping the change process that was already underway in Belo Horizonte towards more sustainable urban drainage and more joined-up water governance.

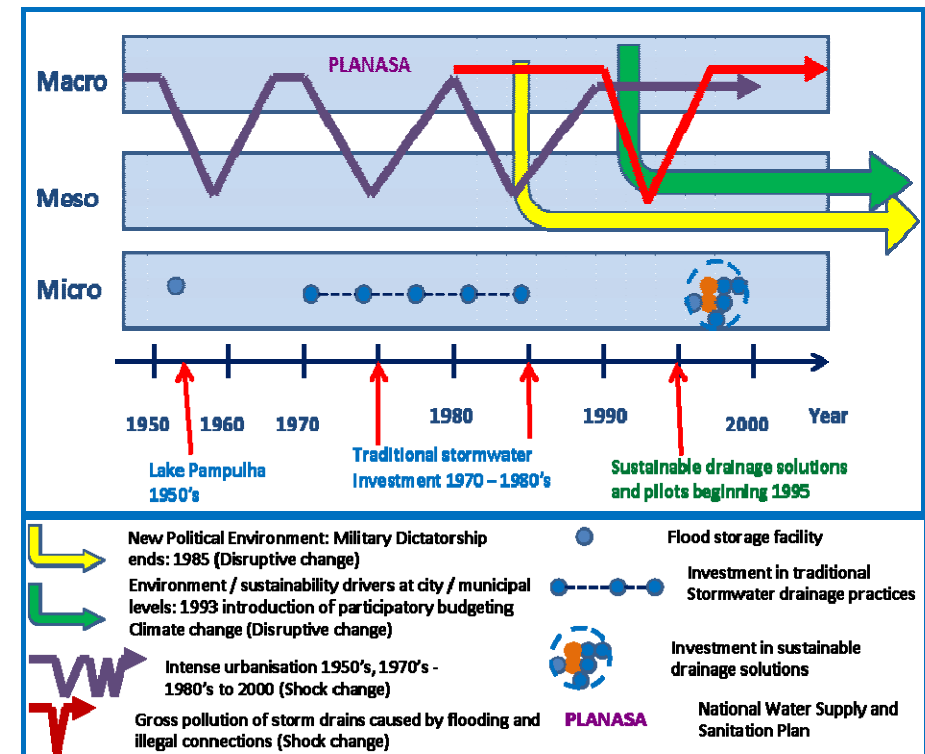

Belo Horizonte 'Historical' Transition Pathways 1950-2010

## SWITCH in Belo – Developing the Transition Arena

The involvement of partners from both municipality & university was crucial to the **SWITCH** successes in Belo Horizonte. A strong Learning Alliance (LA) facilitator within the municipality and a city coordinator in the Federal University of Minas Gerais (UFMG) worked together to implement a balanced set of activities with many stakeholders.

The city team responded positively to key recommendations to improve the city in the city assessment of 2008. This assessment followed the **SWITCH** process by developing a good website and strengthening the institutional level LA. The 2009 'City Summit' in Delft strengthened the local city process since it engaged some carefully selected key actors in the city beyond the core **SWITCH** team.

In particular the following steps were followed:

- Links were built and integrated between different project activities.
- Earlier initiatives and links with other projects & programmes were built on.
- Work was carried out at different scales.

One criticism is that mechanisms for co-operation and joint decision-making on sanitation issues crossing municipal boundaries did not become institutionalised within the duration of **SWITCH**. The only examples of integration were bilateral where there was an immediate shared need. The overall governance over environmental sanitation in BH is strong with clear relationships between strategic (PBH & COMUSA) and operational levels (COPASA) (see diagram on this page).

Because of these strong links and clear responsibilities, the specific niches which were required to be addressed were easily identified and managed through the DRENURBS programme.

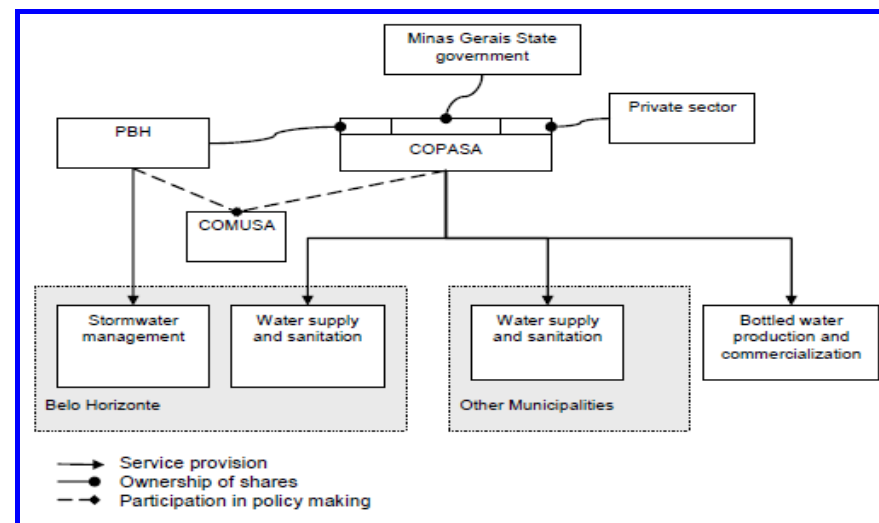

**Relationships in the provision of water services**

- Note:**
- PBH** Belo Horizonte Municipal Council.
  - COPASA** Water and drainage utility.
  - COMUSA** Municipal Sanitation Council (sets priorities).
  - DRENURBS** Programme of improvement measures.





### Towards a more integrated UWM approach 2000 - 2010

The two main parties involved in the **SWITCH** process included the Federal University of Minas Gerais (UFMG) and the Municipality of Belo Horizonte (PBH) whose expectations, although different, were well matched. The municipality required monitoring and research of drainage interventions within neighborhoods and catchments in order to develop the information needed for designing current and future drainage programmes. The UFMG research was to focus on the different aspects of the innovative approaches, drawing on global knowledge transfer.

### Futures and Transition Pathways

A number of recommendations for change and continued improvement were developed in SWITCH:

- Continued discussions on composition and function of COMUSA to strengthen discussions and reflect on its composition and function.
- Address the most appropriate form of social participation.
- Strengthen skills and methods of participation in operational planning. Programmes such as DRENURBS and URBEL's slum upgrading programme (called Vila Viva) need to be documented and shared. Changing the skills profile of staff is a long term process.
- Support the catchment committee operations. In particular the catchment agency has an important role to play in future.
- Seek improved integration at the metropolitan level through participation of neighbouring municipalities in the BH LA.
- Structured exchanges with other Brazilian State capitals. Brazil has a number of cities with similar characteristics and size as BH.
- Further document and disseminate the experiences from BH internationally. Despite weaknesses, mechanisms and structures for participatory planning and decision-making on environmental sanitation hold important lessons for other cities.

### Intervention cycle of the DRENURBS programme

DRENURBS is an ongoing intervention programme which follows the following steps:

- Informal contact with community leaders. The initiative for first contact might come from the community, or from the programme because of problems.
- A rapid assessment is made of the physical situation in an area and also the local knowledge and awareness of environmental issues.
- Establishing and/or strengthening the capacity of the resident committee. The committee is open for anyone to participate and typically consist of 30 people. Its main tasks are: 1) act as communication channel between the community and the PBH; 2) mobilize the community further; 3) monitor & control implementation; iv) capacity building.
- Define the general directions for water course improvements. Community members start to participate in this activity.
- Proposal development for specific interventions. This is done with community participation. This may include proposals for physical interventions and environmental education activities.
- Detailed design of physical interventions. The community reviews the detailed designs and checks whether they meet their criteria.
- Implement the interventions. These included: 1) physical drainage works, 2) land appropriation and resettlement and 3) environmental education activities.
- Monitor and control implementation. The committee checks the day-to-day implementation of the physical works. The quality of the works is checked on monthly visits when explanations are given of works maintenance.
- Handing over responsibility for maintenance. Depending on the type of intervention the works are handed over to PBH or COPASA for maintenance.

## Belo Horizonte Transitioning Strengths

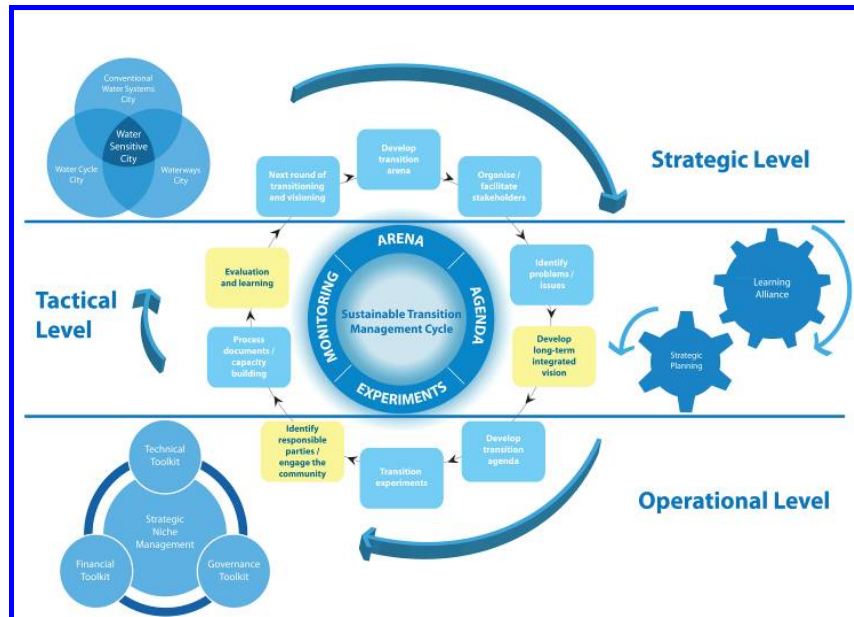

The transition in integrated water management underway in Belo Horizonte is a success for **SWITCH**. There were several key strengths:

- There is a strong transition arena.
- The vision was developed with a focus on IUWM.
- Process documentation preparation strengthened during **SWITCH**.
- Evaluation methodologies were strengthened during **SWITCH**.
- A capacity building programme was put in place during **SWITCH**.
- Rolling out and scaling up of the transition experiments across the city commenced.

It is now important that innovations across the city continue to be up-scaled in Belo Horizonte and other municipalities for the next round of transitioning.

## The extent of the change which occurred

During the five years of the **SWITCH** project there were transition management cycle (TMC) activities in Belo Horizonte over all three levels - tactical, strategic and operational. Belo Horizonte already had several Transition Management Strengths such as a strong stakeholder platform and social inclusion programmes. The city also displayed strengths with process documentation and its willingness to experiment with new technologies. TMC activities in Belo Horizonte include all ten steps of the cycle. A transition towards IUWM in the city is well under way as preparations are made to up-scale demonstrations (experiments) across the city. This should accelerate the integration of new generation systems such as SUDS. Innovative methodologies such as participatory budgeting will be used to deliver the new systems which are becoming widespread, and the traditional practices are less and less used.

## Belo Horizonte Visions for 2038

The following visions for Belo Horizonte - a city of clean waters - were developed during the **SWITCH** project.

The natural environment is valued, integrated with the urban context and owned by the population, in a harmonious coexistence with the dynamic of floods and droughts.

**The desired city** - Belo Horizonte experiences a balance in the income distribution, which can be verified by improved occupancy and use of urban space and makes the city a more fair place. The universal and equitable access to sanitation infrastructure ensure good health conditions and quality of life also to low income households. In this sense, the city receives sanitation actions, opening of roads, elimination of risk areas, treatment of streams, and removal and resettlement of families that live in areas at risk of flooding or landslide. The basins are effectively taken as units of planning, culminating in a integrated management of urban water,

## Section 5 - The Belo Horizonte City Story

both within intra and inter-municipal dimensions, without harm to poor and remote areas.

**The exclusionary city** - Belo Horizonte experiences a continuous worsening of income concentration, revealing a serious frame of social injustice, stagnation in access to sanitation infrastructure and trend to privatization of public space, due to socio-territorial structures of control and segregation. Inequality is also evident in urban water management, which in poor and remote areas ignores the preservation and integration of water courses to urban landscape and community life. Furthermore there is a significant disintegration of intra and inter-municipal policies, undermining the administration of financial resources and reducing the efficiency of programs, projects and actions related to water management.

**The advancing city** - Belo Horizonte experiences a balance in the distribution of income, which can be verified by improved occupancy and use of urban space and makes the city a fairer place. The universal and equitable access to sanitation infrastructure ensure good health conditions and quality of life also to low income households. In this sense, the city receives sanitation actions, opening of roads, elimination of risk areas, treatment of streams, and removal and resettlement of families that live in areas at risk of flooding or landslide. There is, however, a centralized and authoritarian management model, producing significant political disintegration of intra and inter-municipal policies and, in many cases, undermining the administration of financial resources, inhibiting the participation of civil society and reducing the efficiency of programs, projects and actions related to water management.

**The conservative city** - Belo Horizonte experiences a continuous worsening of income concentration, revealing a serious frame of social injustice, stagnation in access to sanitation infrastructure and trend to privatization of public space, due to socio-territorial structures of control and segregation. Inequality is also evident in urban water management, which in poor and remote areas ignores the preservation and integration of water courses to urban landscape and community life. Nevertheless, there is an increasing integration of policies in both intra and inter-

municipal policies, with effective adoption of basins as units of planning and establishment of efficient tools for urban water management.

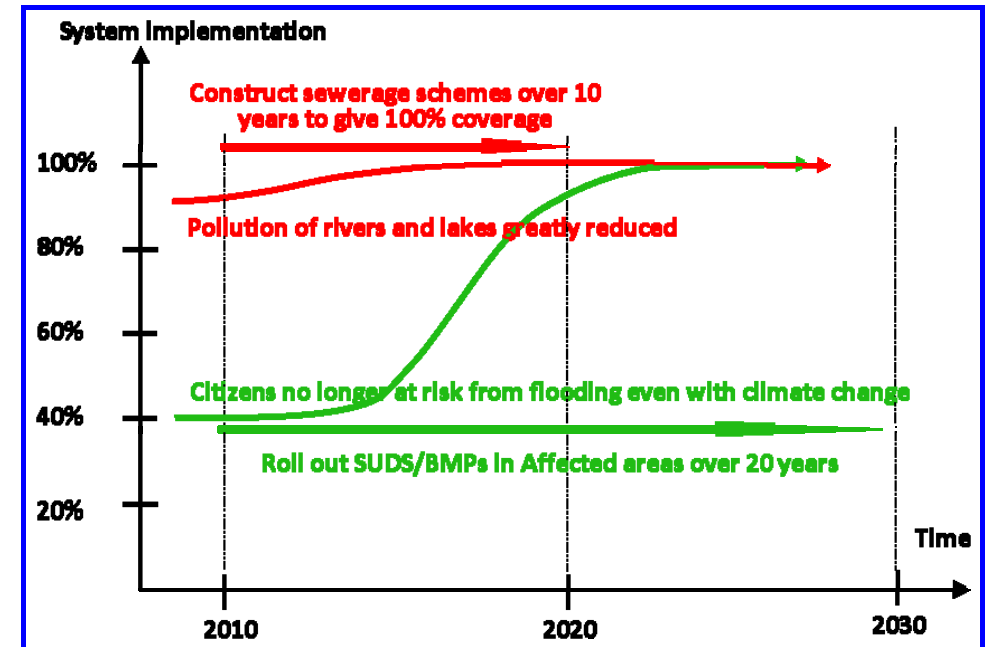

**Potential Future Transition Pathways in Belo Horizonte to 2030**

The transitions diagram for Belo Horizonte has been drawn up to show the two key integrated water management actions for the city;

- Control of pollution in rivers and lakes.
- Reducing citizens from the risks of flooding.



## *Section 6*

# *Example Tools for Transitioning*

## Tools for Transitioning

	Acronym	Name of tool	Page
1	CWIS	City Water Information System	99
2	CWB	City Water Balance	103
3	CWE	City Water Economics	107
4	S4R	SUDS for Roads - A Decision Support Selection Tool	109
5	Infoworks	Removing surface water from sewers	117
6	WDM	Water Demand Management Options	121
7	SUDSLOC	A GIS-Based BMP decision support tool	125
8	SASIW	Systematic Approach for Social Inclusion	129
9		The Economics of Rainwater Harvesting	133
10		Costing for Sustainable Outcomes	139

This final section of the manual outlines a range of decision support tools that have value in facilitating transitions in the water systems of cities. There is a strong argument in favour of not using the technical tools that are used by today's water planners since transitioning has a timespan of as much as fifty years. This manual takes the contrasting view that tools are required to evaluate the current situation and the possible options for a transition path.

The tools cover a range of activities, from analysis of water and drainage networks through financial evaluation to guidance on the governance for micro-industries. Most of the tools included here to assist with transitioning primarily (but not exclusively) consist of **SWITCH** research outputs for niche development within the cities.

These tools support changes and they permit different options to be identified and evaluated, thus helping inform decision makers better. The changes needed are not only about new components or techniques. Means of communicating better are often just as important as further details of the impact of a process on a system. The principal decision making tools developed in SWITCH include City Water Information System (CWIS), City Water Balance (CWB) and City Water Economics (CWE), which all assist with planning and choosing future directions for a city.

### Tools and Niche Management

In the **SWITCH** approach, the water management issues that require to be addressed are identified through the **Learning Alliance**, which decides which ideas and which niches require study and investment. In this context, the niche is the area or system which requires change and improvement. The niche might be better surface water management, or fitting devices for using scarce water more wisely, or even improved communication with customers. Strategic Niche Management is vital for the delivery of sustainable systems by bringing in the different tools and technological innovations that are vital for systems delivery since they provide the knowledge, experience and pathways for a transition to occur.

New ideas need to be rolled out if transitions are to be successfully integrated into the existing systems in a city. These new approaches and ideas need to be developed in relatively protected environments by networks of dedicated actors supporting the new technologies who realise that the niche phase can last for quite a long time.

Niche experiments should normally be aligned with the vision of the stakeholders since stakeholder funding and other support will be needed. Transition experiments may eventually see the innovation replacing current practices and contribute to a sustainable transition. The tools give the science to the evaluations of the niches.

### CWIS - City Water Information System

#### Purpose

The City Water Information System (CWIS) is a Web-based information and knowledge sharing platform to support collaborative groups, such as Learning Alliances, in a planning process.

CWIS supports scenario-planning by hosting the data related to a base case as well as to alternative options providing a basis for decision making.

#### Impact

CWIS enables sharing information and provides a sound framework to analyse, understand and communicate the advantages and disadvantages of a given strategy.

CWIS provides support for the three central roles of CWIS in the SWITCH approach:

- Sharing information,
- Communicating the advantages and disadvantages of different strategies; and,
- Evaluating indicators to help to rank alternatives.

#### Use and operation of CWIS

The backbone of CWIS is its system-based database. The system elements, their related information and their interactions, can be viewed and navigated on a text/image web-like basis (dynamic reporting tool hosting data and reports), on a spatial basis (GIS viewer) and according to the systems logics (system viewer).

CWIS is launched from the website where the application is hosted (see end of the CWIS section). A web browser along with the Silverlight4 plug-in are the only requirements. Once running, the application can also be

installed locally (right-click and install), in order to avoid having to go to the same web site again later on.

#### The tool and its developers

Nexsis is the commercial name of CWIS which will be supported, maintained and further developed by an EPFL (École Polytechnique Fédérale de Lausanne) spin-off company: IPOGEE Consult, 10, avenue de la gare, 1401 Yverdon-les-bains, Switzerland ; [info@ipogee.ch](mailto:info@ipogee.ch)

A live demo can be found on IPOGEE's web site. The tool will be part of SWITCH's global training package.

Visit: <http://home.ipogee.ch/Nexsis/Nexsis.html>

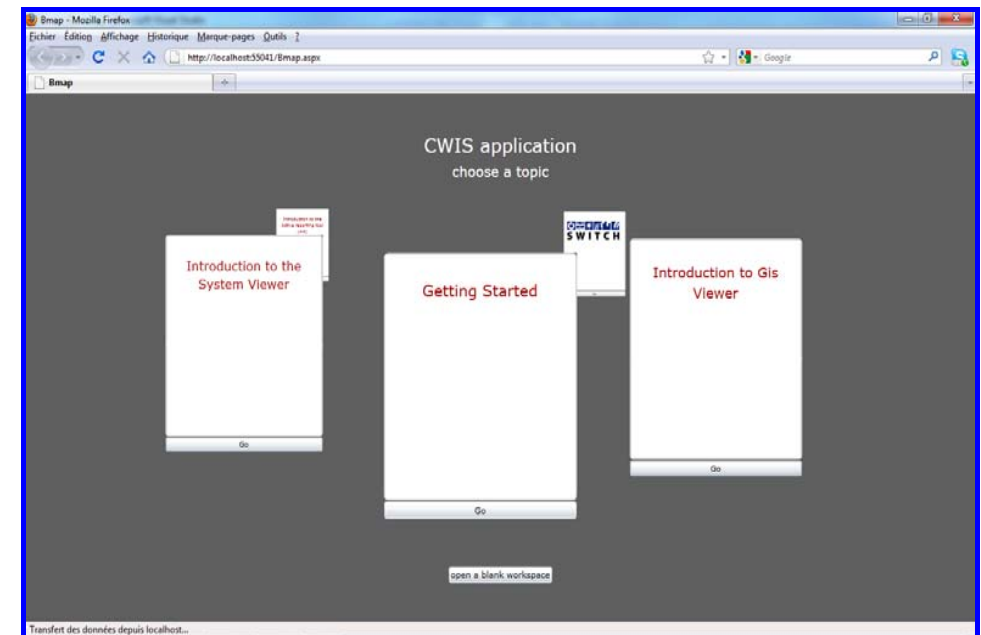

Figure 1. CWIS' welcome dashboard showing a "carousel" of possible entry points

Once started, CWIS launches a configurable dashboard, as illustrated in Figure 1. This dashboard is in the form of a carrousel providing the user with a set of predefined “workspaces” to choose from. Selecting one of these workspaces will open the “views” it contains - spatial, system or report (see below), and will display them in a given “layout” (see below). Alternatively, the starting point can be a blank workspace, which is simply the CWIS’ base user interface.

This base interface has two parts: a main central area that hosts various tools or “views” (see Figure 2) and a left banner that can be docked or hidden away.

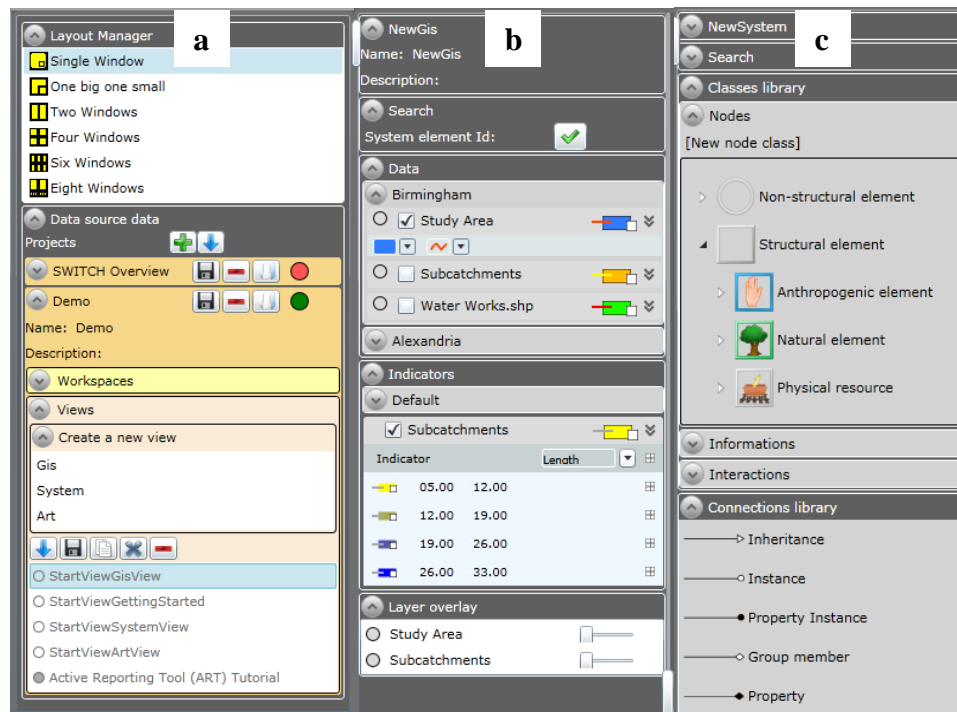

Figure 2. Left banners of (a) the base interface, (b) the GIS viewer and (c) the system viewer

The various views follow the same presentation principle: a dockable left banner hosting various information and commands and a main area showing the content.

The left banner of the base interface has two parts (see Figure 2a):

(1) A Layout Manager used to define the way in which the screen is split into regions to host the various views or modules. Unlike other software, CWIS does not use overlapping tiled windows.

(2) A Project selector lists the projects available. The two buttons allow a new project to be added or the existing list of projects to be loaded. A Project may contain several Workspaces (a saved set of views in a given layout) and Views (System Views, Geographic Views, Reporting Views and Chart Views so far). A Project can be saved, deleted or opened with the buttons that are in its expander header. Similarly, Workspaces can be manipulated (added, loaded, saved or deleted) using the appropriate buttons in the expanding header of the Workspaces.

A loaded view gets a color tag as part of a set of four small buttons (see Figure 3). This color tag button may be used to Drag a view from one region to drop it into another (swap the contents of two regions). Dragging from one view onto another will synchronize the current views selections. The selection synchronization of two views can be extended to additional views. The two right most buttons will minimize and close the view.

The GIS Viewer's left panel (see Figure 2b) host a set of expanders, from top to bottom:

1. Name and meta-data container. To change the view's name.
2. Simple search tool to retrieve a system element.
3. Data expander that contains the data layers eventually grouped by theme. These layers can be switched on/off and their colours and formatting changed.



## Example 1 – City Water Information System

- Indicator expander, onto which the data layers can be dropped. An indicator layer can be configured with much more details to achieve a thematic map and/or to add and configure labels.
- Layer manager allows changes to the overlay order of the different layers, show and hide a layer and change its overall opacity.

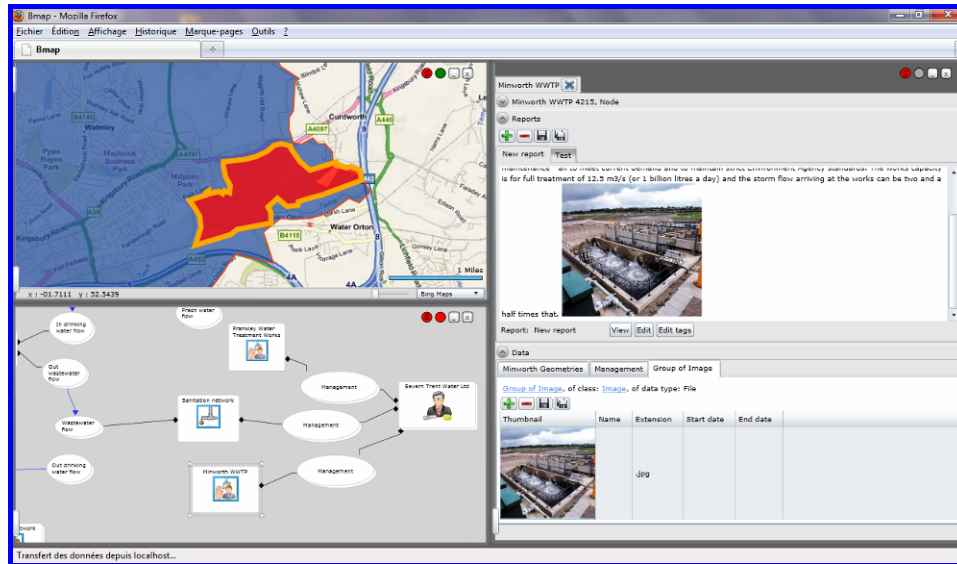

**Figure 3. The synchronized GIS, Systemic and reporting tools.**

This screen shows Birmingham's Minworth WWTP on a map, in a system diagram and in a report/data window (all left banners hidden).

Map panning is achieved by a "Press-Move-Release" on the mouse's left button, whereas zooming is set on the mouse scroll button. The Shift-Key-Click enables selection of an object. Finally, the map area has a background layer (road maps, aerial images, etc.) that can be selected in the bottom right drop down list and its opacity changed with the slider that sits just next to it (see Figure 3).

The System View's left panel hosts a set of expanders, from top to bottom:

1. A name and meta-data container,
2. A simple search tool to retrieve a system element on the basis of its ID. The searched item can be dragged and dropped onto the graphic area.
3. A class library, i.e. the set of system elements that have been defined so far to describe urban water management (see below for some conceptual details) and may be used to draw System Views. System elements can be dragged and dropped onto the graphic area to be added to the System View. The standard operation is to add a group.

System elements are defined along two axes: the type and the level. The possible types are "node", "interaction" or/and "information". A node is a system element, such as a lake, a person or a policy. An interaction is a flux or an influence between two groups. Finally, information is an actual value whose format can be a numeric value, a text, a geometry, a file, or a lifetime. The possible levels are "class", "instance" or "property". A class is an abstract template allowing the creation of instances based on its definition. For example, a given, real-world lake is an instance of the "lake" class defining what a lake is. Properties of an element are classes used within the context of an element. For example, a car may have properties such as "number of wheels", "colour", etc. The latter are instances of the wheel and colour classes, within the context of a car. As cars have more than one wheel, and maybe different colours, these properties are also called "groups". Interactions are also properties, but cannot be considered as a group or an instance (it can be a class, though). Overall, the combination of the two axes (type and level) produces eight different constructs (interaction being not represented as an instance).

4. Connection library. This library provides the five types of structural connections that may be needed to describe the system logics of system elements' interconnections:
  - i. Inheritance - the connection between a parent class and one of its children class or subclass.
  - ii. Instance - the connection between an instance and its parent class.
  - iii. Property Instance - the connection between a property and its parent class.
  - iv. Membership - the connection between an element and the group it belongs to.
  - v. Property - the connection between a property and the element it describes.

Navigating the system logics of the dataset is achieved by an "exploration mode" that is activated/deactivated by pressing the E-Key ( or Ctrl-E). In exploration mode, Shift-Click on an item will retrieve its underlying connected elements. These elements may then be added to the "crisp" view by a Ctrl-Click. Panning is achieved by a "Press-Move-Release" on the mouse's left button, whereas zooming is set on the mouse scroll button.

The reporting tool's left banner of the only contains the shared name and meta-data container and simple search tool. The core part of the active reporting tool consists of a TabControl with a Tab for each system element in the current selection. Each system element's tab is divided into three sections:

- i. Some general information regarding the current system element itself, such as Icon, Id, Parent Class, Name, etc...
- ii. A series of reports relating to the current system element. Control buttons allow for adding a new report, to delete an existing report, to save the current report and to save the whole collection of reports for

the current item. In addition, three buttons named "View", "Edit" and "Edit tags" allow switching between the simple viewing mode and two editing modes, a simple text editor and a slightly more complex tag based editor mode. In the latter case, the view is divided into two parts with, on the left side, the simple text editor and on the right the tagged editor, with two arrow buttons the update an editor with changes that have been made.

- iii. A data catalogue, hosting the various information groups connected to the current system element. Data can be numerical values, texts (including internal links, to other objects in the database, and web links), files (image, video, sound, pdf, etc.), or geometries. Data can be loaded and edited (to some extent), and then used to populate reports, either in static or dynamic mode, the latter allowing for automatic update of the reports when the base information changes.

#### **Note about Silverlight**

\*\*If not present, the Silverlight plug-in is automatically downloaded and installed. Yet this requires administrative rights for the computer in use.

### CWB - City Water Balance

#### Purpose

City Water Balance is a tool for mapping water issues in cities - water demand, supply, drainage, treatment and reuse. CWB is an urban hydrological model using simplified descriptions of the major flows through the city. It enables the impact of changing these features either locally or globally to be scoped. Alternative water management options can be scoped using CWB more efficiently and with lower resources than using more complex design and simulation tools.

#### Impact

All tools currently available are primarily design tools and better planning of water management issues is possible using a tool such as CWB.

#### Use and operation of CWB

CWB is based on readily available data sets and provides simple performance indicator outputs. It models all elements of the water system (natural and man-made) and uses basic land use mapping.

The core principle is of unit blocks of resource and demand. Each unit block is a mini-cluster with identical attributes having rapid descriptions. Sub-catchments also form the basis of the model.

CWB is primarily intended for scoping calculations, uses a daily timestep and gives indicative results. Groundwater recharge is predicted as a product of the simulations. The Model has been tested using the **SWITCH** Birmingham Case Study – calibration is essential.

#### The tool and its developers

CWB was developed at the University of Birmingham and is based on spreadsheets. Please contact Rae Mackay [R.MACKAY@bham.ac.uk](mailto:R.MACKAY@bham.ac.uk)

#### Introduction

The spatial hierarchy (See Figure 4) uses the Unit Block as the basic unit of area.

Minicluster - a land area covered by unit blocks of the same type

Sub-catchment - a common drainage area

Study Area (=City) - the whole area to be modeled

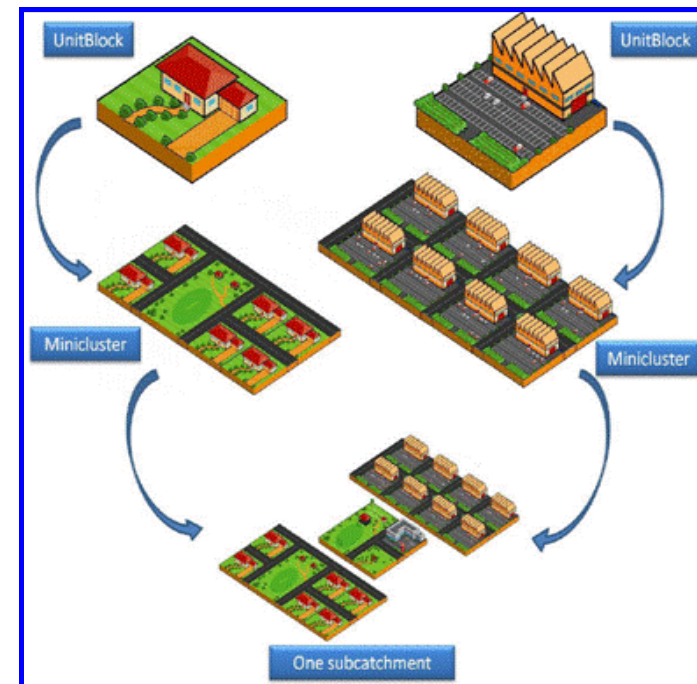

Figure 4 Spatial Hierarchy Diagram

The unit block consists of pervious and impervious areas and a water demand profile. An example of a unit block is a detached house that has roof, paved and garden area as well as an indoor water and possible irrigation demand. Blocks include internal models for water transfer, storage and quality variations (see Figure 5).

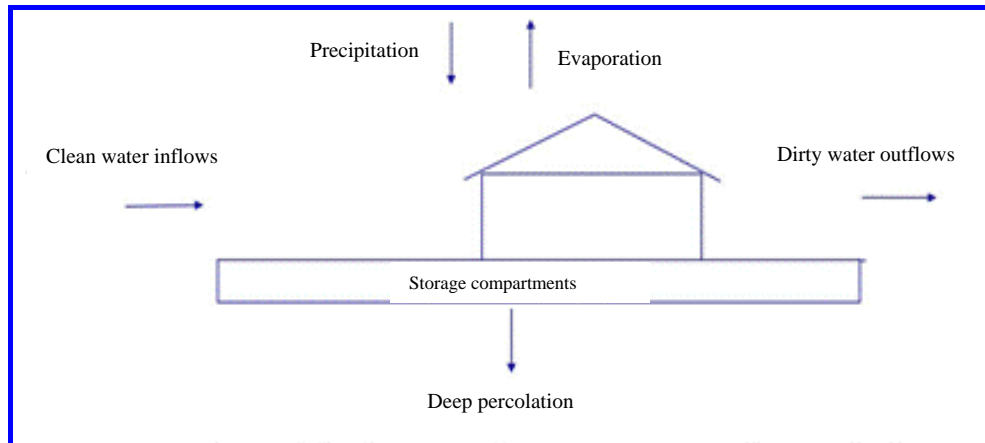

Figure 5. Internal models for transfers, storage, quality variations (identified for each unit block)

**Miniclusters** use additional unit block data to define land use for miniclusters. The land use might be the area of road, public open space (split into wooded or non wooded), water use for public open space, area irrigated and the trigger to irrigate.

**Soil Stores** - CWB incorporates the amount of water stored in the soil horizons.

**SUDS (BMPs) in CWB** - A wide range of SUDS types can be taken into account as may be seen in Table 5.

Table 5. SUDS in City Water Balance

Unitblock scale	Minicluster scale	Large Scale
Green roofs	Filter strips	Stormwater stores
Raintanks	Stormwater stores	Detention Basins
Swales	Swales	Retention Ponds
Soakaways	Soakaways	

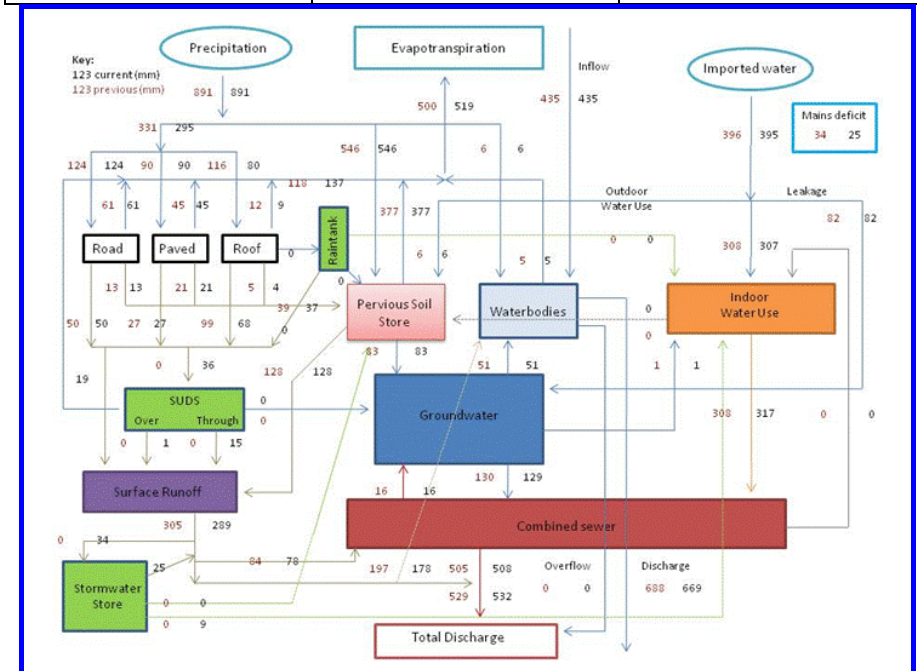

Figure 6. City Water Balance Output – Flows in the catchment

Example of the application of CWB in Minworth, Birmingham.

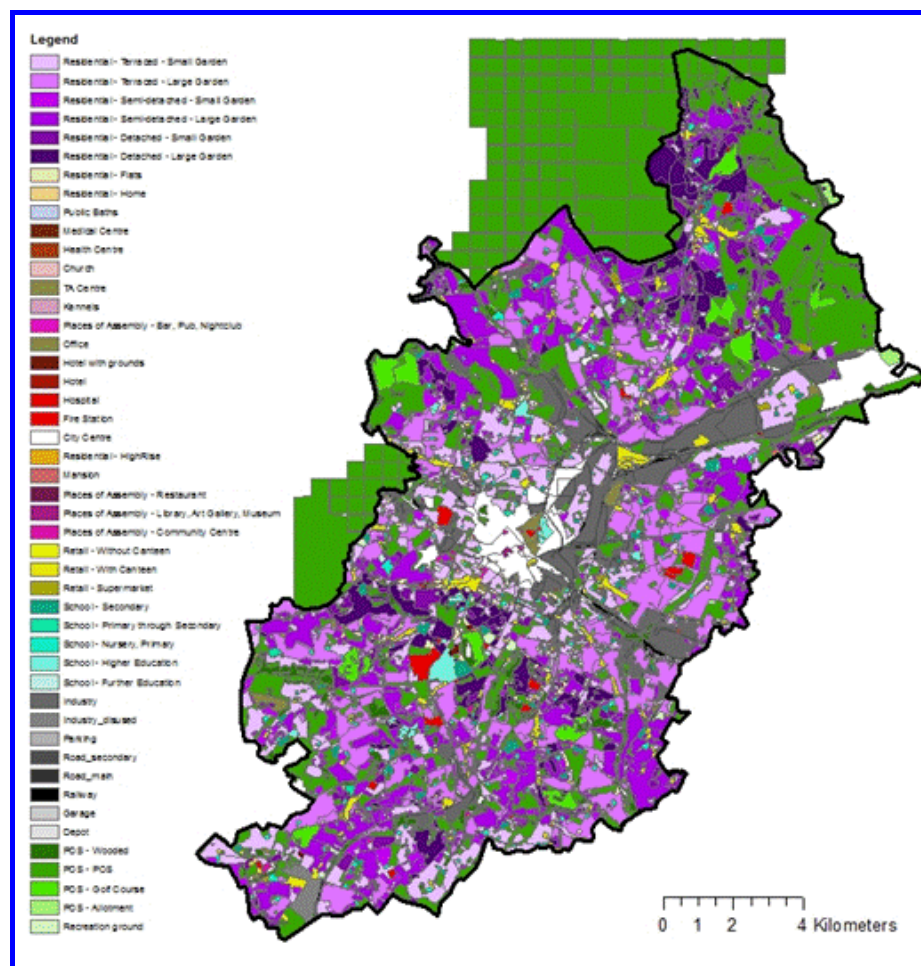

Figure 7. Land-use plan of the Minworth catchment, Birmingham

### Scenario testing

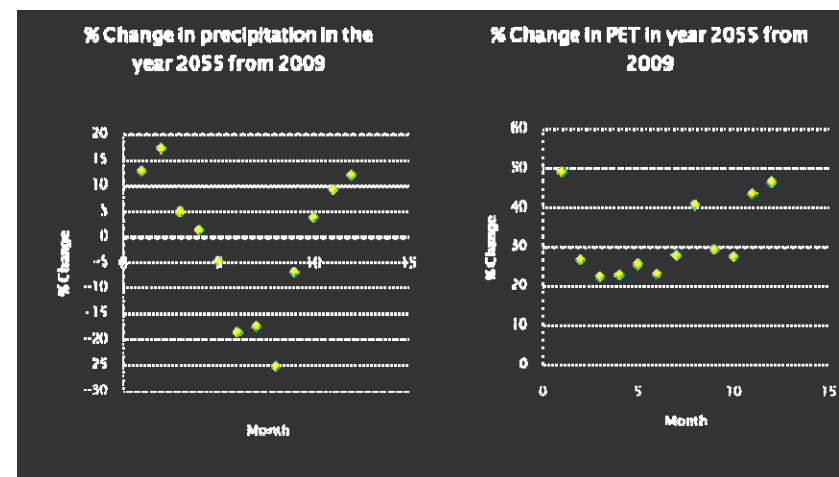

Figure 8. Scenarios from 2009 to 2050

### Scenarios for future in Birmingham evaluated using CWB.

A range of scenarios can be tested (Figure 8)

- Population doubled, 30% brown roofs, interrupted mains supply. Increased leakage.
- Population doubled, 50 l/c/day supply from mains, recycled water to make up deficit, increased leakage, increased flash flooding.
- Population stable. Mains water treated to non-potable standard, increased urban agriculture.

## Groundwater change evaluation using CWB

GW level responses on average to the revised climate state predicted for 2055 but using the current 2009 waterscape for the city (Figure 9).

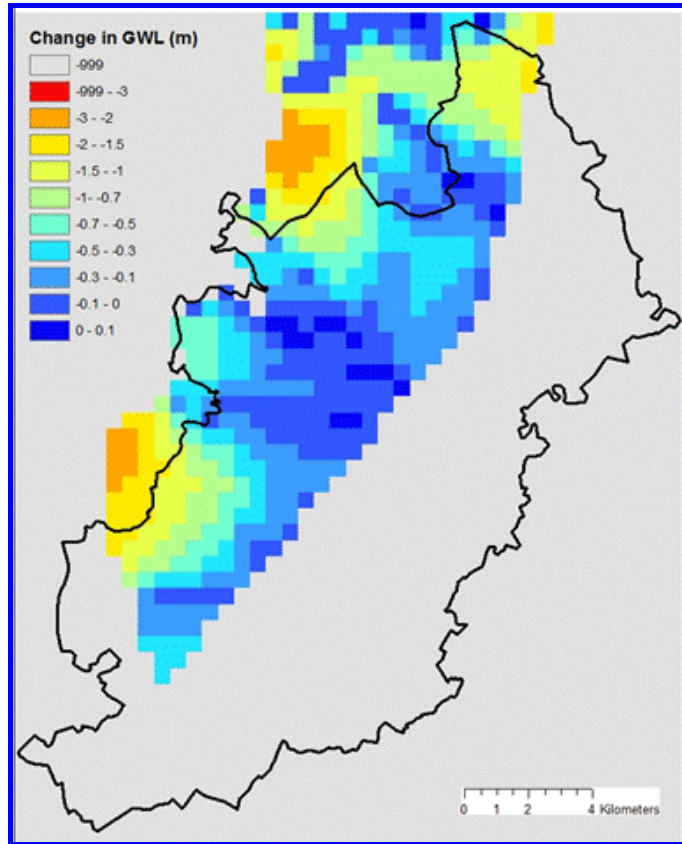
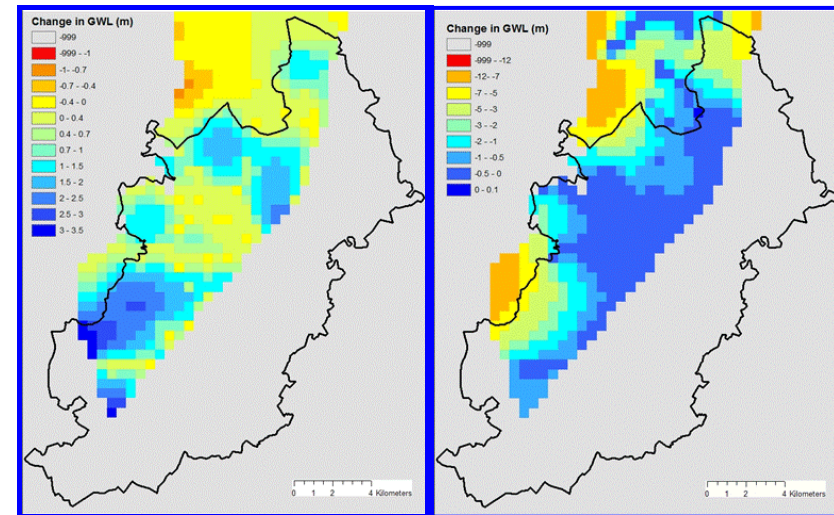

Figure 9. Change in GWL from 2055 base case to Scenario 1 business as usual



Scenario 1

Scenario 2

### Scenarios Examined

1. **Business as Usual** - City centre and residential occupancy doubled since 2009. Mains leakage increased to 35% Residential demand assumed to be 130 l/c/day
2. **Brown roofs** applied to all non-residential buildings, high-rise, apartments, old people's homes and detached residential buildings. Supply irrigation to pervious stores with large -scale treated wastewater reuse

Further testing is taking place in other cities and indications are that the current model requires extension to model boundary flows more fully. Sincerest thanks go to Severn Trent Water for providing the water and wastewater data for Birmingham.

### CWE - City Water Economics

#### Purpose

The purpose of CWE is to assess alternative tariff and pricing schemes for achieving financial sustainability in the provision of urban water services and for evaluating economic incentives towards efficient water use and decentralized management.

#### Impact

CWE addresses strategic planning questions for both developed and developing countries. It can be used to provide rapid answers to questions regarding the recovery of costs and subsidies required to fund future UWM plans, the implications of cost recovery policies and objectives, and the distributive effects and incentives of current (or potential) tariff schemes.

#### Use and operation of CWE

Water pricing and cost recovery in the provision of water services are receiving increasing attention in both developed and developing countries. In the EU, the implementation of article 9 of the Water Framework Directive requires the adequate contribution of water uses to the costs of water services, demanding the allocation of water service costs in an equitable way, that implements the “polluter-pays” principle. In developing countries, the financial sustainability of water services, the affordability of water-related charges and access to basic water services constitute horizontal policy goals. In the latter case, it is often argued that tariffs should not be the primary instrument to raise the funds required for capacity expansion since this would substantially raise the costs borne by low-income groups. Nevertheless, even in this case, tariff schemes should raise adequate resources for meeting annual operating and maintenance costs and provide incentives to encourage water saving practices to avoid future, costly supply enhancement alternatives.

The main concept behind City Water Economics pertains to the assessment of the implications of different forms of institutional

organization and of alternative cost allocation schemes. These are examined from two perspectives: (a) the perspective of those dealing with water service provision at various levels (metropolitan area, metropolitan area subset, river basin) and (b) from the social perspective, with emphasis placed on social equity, affordability and incentives offered by alternative pricing schemes and cost allocation mechanisms.

Schemes and instruments can be formulated and evaluated for broad time periods, allowing the impacts of potential changes to consumption patterns, costs, infrastructure and strategic interventions to be mapped. Output indicators concern both the achievement of objectives relating to cost recovery and revenue sufficiency, and the potential social implications and distributive effects of employed instruments. A sensitivity analysis can also be undertaken to assess the potential impact of demand elasticities on cost recovery objectives and affordability indicators.

#### The tool and its developers

CWE was developed within the framework of the SWITCH work packages 1.2 and 1.4, and is part of the City Water Suite of tools. CWE can also be used as an independent Decision Support System for the scoping assessment of cost recovery schemes and economic incentives in urban water management.

The developers were Eleni Manoli and Dionysis Assimacopoulos, School of Chemical Engineering, National Technical University of Athens, Greece. Contact: [assim@chemeng.ntua.gr](mailto:assim@chemeng.ntua.gr)

#### Methodology and model structure

The interface of CWE implements the main model functionalities and encompasses the following steps (Figure 10): (i) Case Configuration, (ii) Definition of the framework for water service provision, (iii) Cost allocation among water service providers, (iv)

Definition of pricing schemes, and (v) Calculation of output indicators and sensitivity analysis.

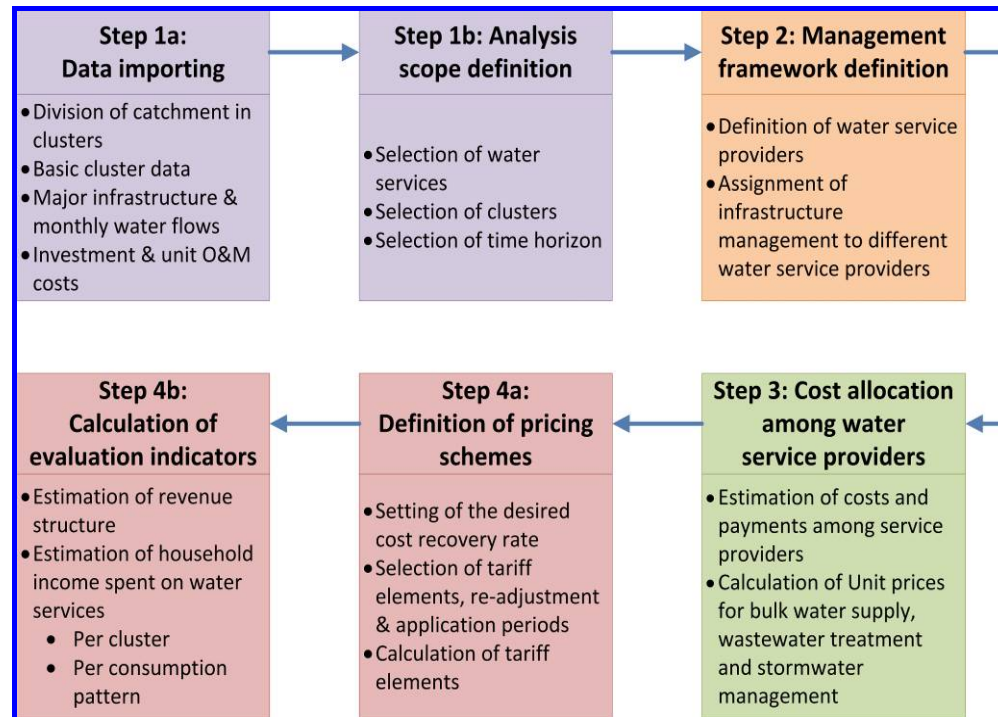

Figure 10: The CWE Analysis steps

The **configuration of a case** analysed within CWE (Figure 11) concerns the input of baseline data for a case to be developed and evaluated by the model. In CWE, a case is defined through the conceptualization or a scenario of the framework for water service provision and the definition of alternative pricing schemes for different water services. Relevant data and parameters concern (a) water flows and infrastructure elements for water supply, wastewater collection and treatment and stormwater management, over a specific timeframe (current or for a future plan), (b)

water service areas, and (c) reference data on income and consumption distribution among different population segments in the service areas.

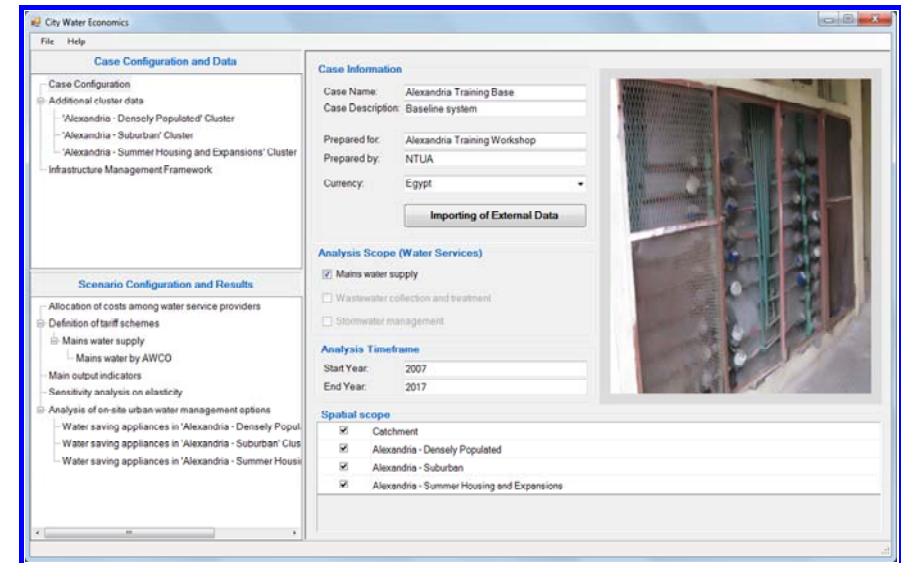

Figure 11: Configuring a case in City Water Economics

The **framework for water service provision** for the area of interest is mapped through the definition of all agents involved in the development, operation and maintenance of water supply, wastewater collection and treatment and stormwater systems, and their respective roles. This expands beyond the simple definition of utilities and authorities concerned with network management and rehabilitation, to also address more complex frameworks, involving agencies/management entities dealing with the management of storage reservoirs and conveyance networks upstream or downstream of the urban water system, and potential institutional reforms.



## Example 3 – City Water Economics

On the basis of this framework, CWE **calculates and allocates** capital, operation and maintenance **costs among water service providers**. Desired cost recovery objectives at this level can be attained through the estimation of the relative bulk prices. These are based on the “user-pays” principle, i.e. the payment for water services received is equal to the cost that corresponds to these services. Bulk prices can also be user-assigned to address the case where these are the output of negotiations or government regulation.

**Table 6. Pricing methods modeled in City Water Economics**

Urban water service	Tariff element	Methods (per household or unit block)
Mains water supply	Fixed charge	<ul style="list-style-type: none"> <li>Per unit of property area</li> <li>Independent (per household)</li> </ul>
	Volumetric charge	<ul style="list-style-type: none"> <li>None</li> <li>Uniform volumetric rate</li> <li>Increasing Block Rate</li> <li>Decreasing Block Rate</li> </ul>
Sewerage collection and treatment	Fixed charge	<ul style="list-style-type: none"> <li>Per unit of property area</li> <li>Independent</li> </ul>
	Volumetric charge	<ul style="list-style-type: none"> <li>Share of mains volumetric bill</li> <li>Uniform rate, based on share of mains water consumption</li> </ul>
Stormwater management	Fixed charge	<ul style="list-style-type: none"> <li>Per unit of property area</li> <li>Independent</li> </ul>
	Variable charge	<ul style="list-style-type: none"> <li>Per unit of impervious property area</li> </ul>

Tariff schemes for each urban water service can incorporate different elements, depending on overall goals and objectives. City Water Economics incorporates different, widely applicable, methods that can incorporate both fixed and variable charges (Table 6). Rates are calculated by the model according to desired cost recovery objectives over specific timeframes and periods.

Main **output indicators** concern: (a) the affordability of water charges, expressed as the annual expenditure and the corresponding income share spent on water services; (b) revenue patterns for water service providers, specifically analyzing the ratio of collected fees in relation to different cost elements; (c) the potential impact of demand elasticities to the range of objectives set; and (d) the rate of return and payback period for decentralized closed-loop systems (rain tanks, SUDS, on-site wastewater treatment and reuse etc) and water saving appliances.

### Applications to-date

Within the framework of SWITCH, City Water Economics has been applied to assess costs, alternative tariff schemes and economic instruments in Birmingham, Alexandria and Accra. Case applications were diverse, according to specific strategic planning objectives in the respective cities, and are summarized in the Table below.

**Table 7. Applications of City Water Economics in SWITCH**

City/Area	Application Scope
Upper Rea, Birmingham	Costs of Sustainable Urban Drainage Strategies and relevant economic instruments
Alexandria Metropolitan Area	Improved cost recovery for potable water supply Incentives towards demand management
Accra Metropolitan area	Affordability of current framework in water supply and management Economic impacts of strategies for improved water supply and sanitation

The following section summarizes methodology and key results from the **Alexandria** application. Further information and results for all case applications can be found in the City Water Economics User and Reference Manual.

## The Alexandria Case Study

### Background and motivation

Urban water management in Alexandria has so far followed a centralized approach focused on supply enhancement and network expansion to provide adequate water supply to the city's inhabitants (current connection rate ~ 95%). Potable water supply in the wider metropolitan area is managed by the Alexandria Water Company (AWCO), which also supplies water to the Governorates of Behira and Marsha-Matrouh (Figure 12). The total daily production from the 8 water treatment plants operated by AWCO is about 2.5-3 hm<sup>3</sup>/d; of this amount, about 36% corresponds to leakage and unaccounted for water.

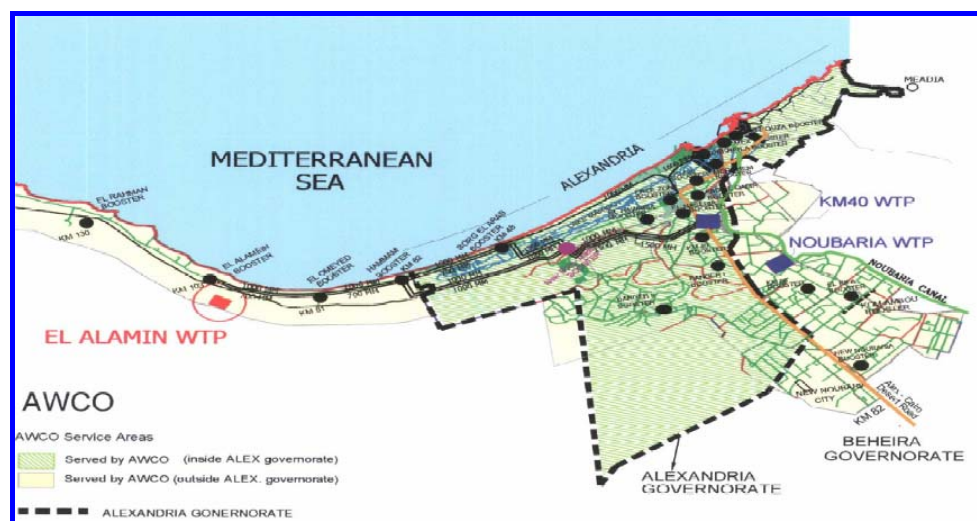

Figure 12: Base map of the areas serviced by the AWCO

The high rate of losses, the high per capita consumption (estimates of 200 l/cap/d), and the dependence from Nile waters, which are also used for crop irrigation, underline the need for orienting policies towards water demand management. To that end, options examined within the

framework of SWITCH have involved the cost-benefit assessment of leakage reduction programmes, the introduction of incentives for the installation of water saving appliances, and tariff reforms. The latter, according to the company's objectives, should ensure affordability of water-related charges, while at the same time improve cost recovery and provide incentives towards efficient use. In the above context, the application of City Water Economics focused on two aspects:

- The preliminary assessment of alternative tariff schemes for improving cost recovery in potable water supply provision, and;
- The evaluation of incentives offered by current and potential pricing policies for the installation of water saving appliances in households.

The CWE application was based on data from two studies developed by SWITCH to support the Alexandria Strategic Planning process, the Water Demand Management Study, and the Study on "Whole of System Modeling and Decision Support".

### Development and assessment of alternative tariff schemes

The current tariff structure for residential water supply follows an Increasing Block Rate structure, and is presented in Table 8.

Table 8. Current AWCO tariff for residential water supply

Block (m <sup>3</sup> /HH/month)	Current rate (EGP/m <sup>3</sup> )	% variation of block rate in comparison to the 1 <sup>st</sup> block
0-20	0.23	-
20-30	0.25	110%
>30	0.35	150%

An assessment of this tariff scheme through CWE has portrayed that:

- Current revenues from residential tariffs correspond only to 36% of the total annual operational and maintenance costs of AWCO,

## Example 3 – City Water Economics

whereas residential water consumption accounts for about 60% of the total;

- The majority of consumers (~87%) falls within the final consumption block; as most consumers face the same water price for the largest share of their water consumption, the current tariff provides limited incentive for water conservation.

**Table 9. Objectives of tariff schemes modeled in CWE**

Tariff objective	Implementation in CWE
Improved cost recovery	<ul style="list-style-type: none"> <li>Targeted cost recovery rate of 100% for O&amp;M and 65% for investment costs (the remaining 35% is funded by the State)</li> <li>2-year readjustment periods to account for changes in costs, population growth and consumption patterns</li> </ul>
Enhancement of incentives	<ul style="list-style-type: none"> <li>Introduction of 2 additional consumption blocks and higher variation of rates with regard to the first block</li> </ul>
Affordability	<ul style="list-style-type: none"> <li>Higher variation of rates with regard to the first block, so that the largest share of costs is borne by higher income households, also consuming the largest share of the resource</li> </ul>
Ease of implementation	<ul style="list-style-type: none"> <li>4-month billing periods</li> </ul>
Enhancement of revenue stability	<ul style="list-style-type: none"> <li>Introduction of fixed charges to recover 50% of the attributed capital costs</li> </ul>

A similar perception is shared by the AWCO, which considers that future policies should entail a gradual tariff increase, to discourage wasteful water use, and ameliorate cost recovery. To that end, the tariff scheme assessed through CWE was formulated according to the objectives of Table 9.

A second tariff scheme also incorporated seasonal water rates, to account for the large variation between summer and winter water consumption,

which requires the development of additional infrastructure (and thus higher cost) to cope with peak water demands.

Figure 13 (i and ii) present the calculated volumetric rates for the two schemes, in comparison to those currently applied. Affordability was a key criterion for the evaluation of schemes. Figure 14 presents the results obtained for each income class, as the share of average income spent on water supply charges. According to the estimate, the schemes developed allow for improving the overall recovery of costs, while the share of income spent on water services for low income households remains below the 5% threshold, and can thus be considered affordable.

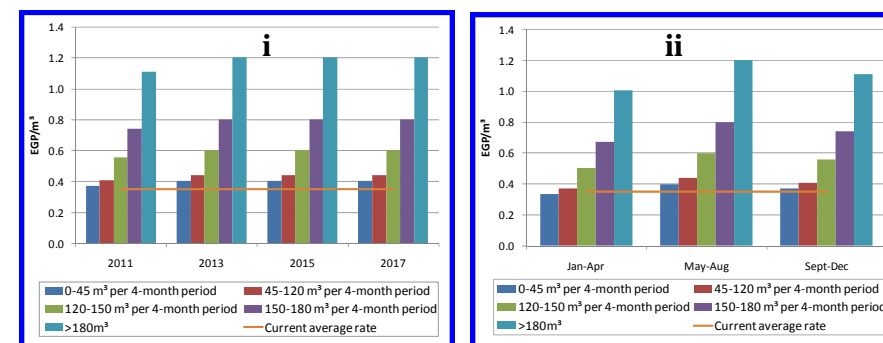

**Figure 13: Volumetric rates for the two tariff schemes modeled in CWE: (i) 2011-2017 rates vs. currently applied (tariff scheme a) and (ii) 2011 seasonal rates (tariff scheme b)**

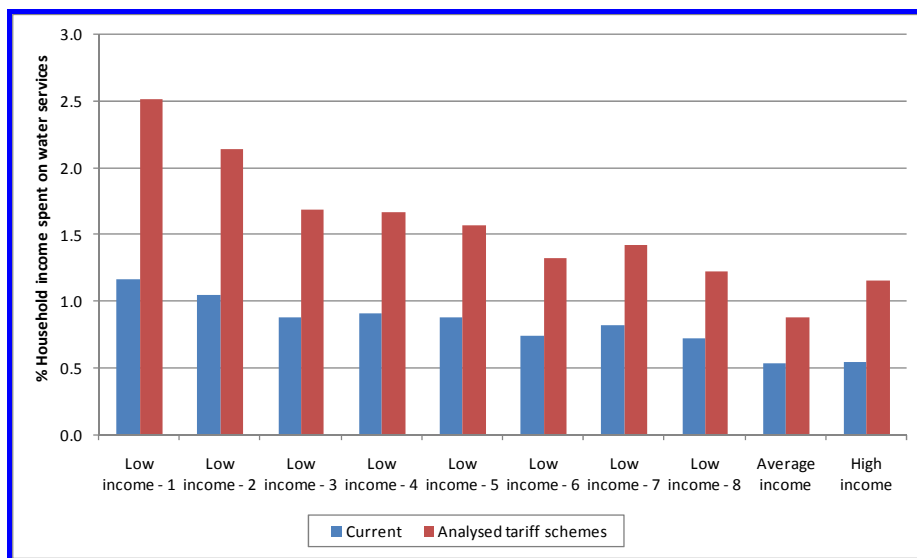

**Figure 14: Share of income spent on water services for current and analysed tariff schemes**

### *Incentives towards demand management*

A second application of CWE in Alexandria concerned the evaluation of incentives offered by the current system and tariff schemes for the installation of water service devices in homes. The SWITCH Water Demand Management Study for Alexandria examines alternatives to support this intervention. According to estimates, the average cost per household would amount to 72 EGP. The proposed strategy involves financial and technical support by AWCO for the purchase, installation and maintenance of water saving devices. This support will be recovered through an additional charge on the water bill for the households concerned.

The aim of this CWE application has been to evaluate whether current and proposed schemes offer the incentive required or whether additional funding and economic support would be required. The assessment is

made by calculating the annual savings for a 5-year period for an average household, as a result of the reduction of water consumption and thus of expenditure for mains water supply. Results are presented in Table 10.

**Table 10. Incentives for the installation of water saving devices**

Scheme	Savings from expenditure for mains water supply (Average household, 2011 values)	Payback period (years)
Current tariff	105 EGP	<1
Alternative 1: Non-seasonal rates	235 EGP	<1
Alternative 2: Seasonal rates	236 EGP	<1

In all cases analysed, the payback period is less than 1 year, implying that (a) subsidies are not required, even without tariff reforms, (b) a tariff reform, combined with information and awareness campaigns could yield results similar to the strategy proposed by AWCO.

Note: **EGP** = Egyptian Pounds

### SUDS for Roads – A Decision Support Selection Tool

#### Purpose

The selection of appropriate sustainable drainage systems (SUDS) for Local Roads.

#### Impact

This is a design selection tool for practitioners to improve the appropriateness of SUDS selected for Roads. The tool has been written for roads engineers.

#### Use and operation of S4R

S4R is a guidance document to advise on the selection of options. The flowchart in this section forms the basis of the selection process.

#### The tool and its developers

This tool was developed under the direction of the Sustainable Urban Drainage Working Party (Scotland) which is the Scottish stakeholder group steering the national implementation of SUDS. The document was written by Mr Chris Pittner of WSP consultants ([Chris.Pittner@WSPGroup.com](mailto:Chris.Pittner@WSPGroup.com)). The selection tool was developed by Taye Akinrele and Chris Jefferies ([c.jefferies@abertay.ac.uk](mailto:c.jefferies@abertay.ac.uk)).

#### Background

Even though it is widely acknowledged that there is a need to have a paradigm shift in the way water is managed in the urban environment, urban water managers and policy makers struggle with the challenge of transitioning to the practice of sustainable urban water management. One of the major impediments to transitioning into sustainable urban stormwater management is the lack of manuals, toolkits, guidelines and standards to deal with new generation systems.

Road designers need to design effective sustainable drainage as well as ensuring a safe environment for traffic. The long term nature of engineering works means that design tends to be conservative and

changes that might cause trouble in future are difficult to implement. Roads are now multifunctional and must provide much more than sealed surfaces for modern day transport. In Scotland, Sustainable Urban Drainage Systems (SUDS) have come a long way as a viable and sustainable alternative to the “end-of-pipe” treatment of urban road runoff, yet the uptake by road drainage engineers has been slow. One barrier is the lack of clarity on the appropriateness of the different SUDS type for the different road types.

SUDS should be selected by using an appropriate selection criterion that serves to identify the capabilities and limitations of each SUDS for use on any proposed road. The use and applications of SUDS in the UK involves multiple stakeholder collaboration. Multiple stakeholders often have conflicting and sometimes divergent objectives. The decision support tool developed thus guides the decision-making process by providing sets of alternatives, a set of criteria for comparing the alternatives, and a method for ranking the alternatives to the stakeholders.

The S4R Support Tool comprises a SUDS Selection Flowchart and matrices to assist in making the correct choice for local roads. To support the flowchart there are three matrices for SUDS based on a hierarchy of roads typically found in Scotland: Options, Performance and Maintenance.

The site factor score provides a common assessment of the different opportunities and constraints offered by the SUDS options for a site. The scores for different options are used to rank the options so that the merits of the different arrangements can be openly considered.

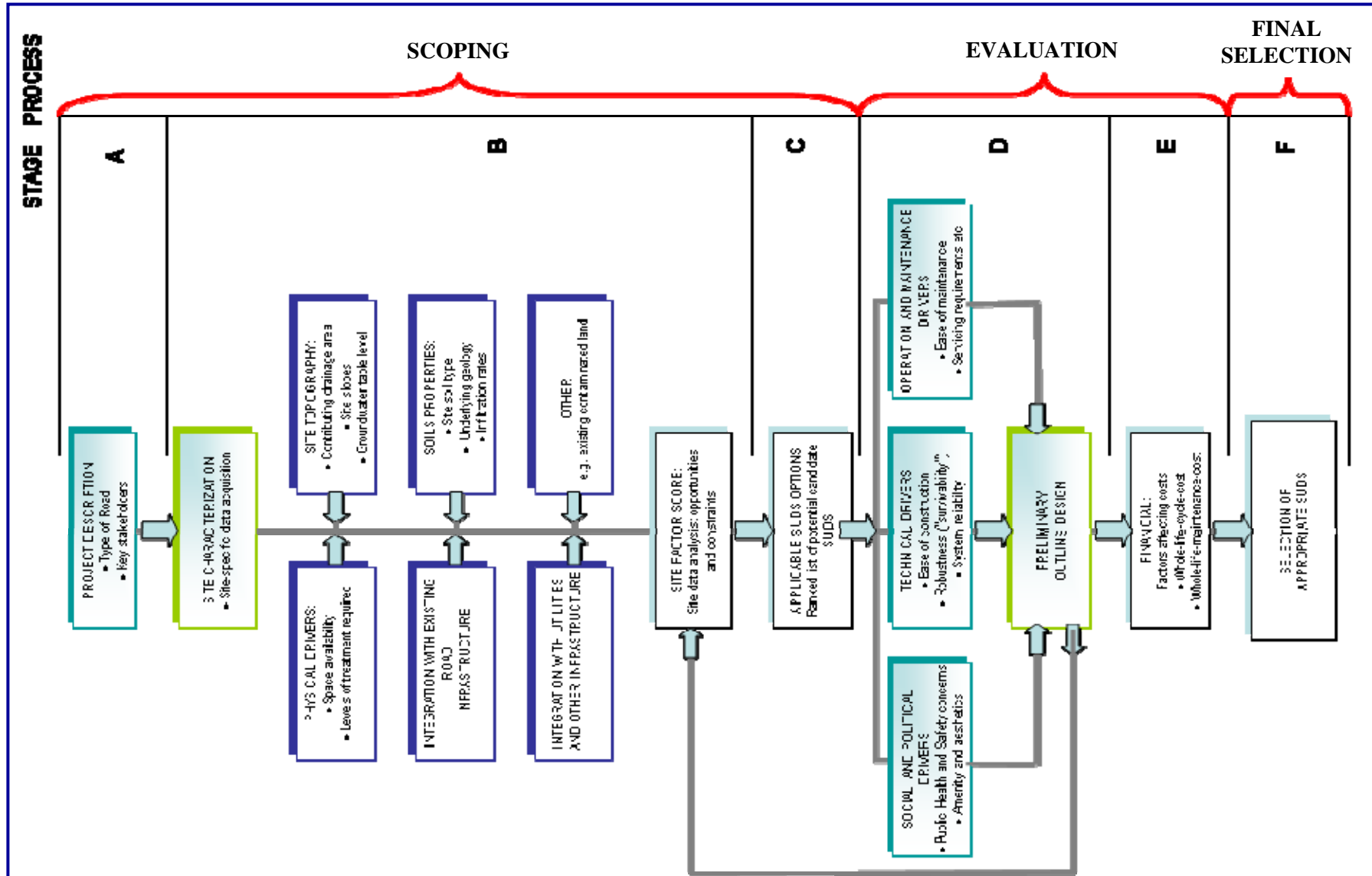

Figure 15. Road SUDS Selection Flowchart

The Roads SUDS Selection Flowchart (Figure 15) is classified into three main processes of scoping, evaluation and final selection, and the process is iterative rather than linear. The Flowchart involves six main stages: Site Description; Characterisation; Applicable Options; Preliminary Design; Financial Considerations, and; Selection.

The selection tool is not intended as a set of definitive rules defining which SUDS components should be used, but it provides a common basis for discussion and negotiations in deciding the most appropriate solution for a location. The process of scoping comprises of stages A-C. The evaluation stage is stages D-E. The final selection stage is stage F.

Stage A clarifies the type of road to be developed. The designer then uses the 'road options matrix' to select a range of SUDS options that are potentially suitable for that particular road type. Key stakeholders should also be recognized at this stage.

Stage B is the site characterization stage. Each of the range of options initially selected using the selection matrix is scored on the basis of whether they meet the particular criteria for the location. When they meet an individual site-specific criterion, they are given a score of 1, otherwise the score is zero. The exception to this rule is the level of treatment, which must be the number of levels of treatment required. The site factor score is the sum of the individual scores for each SUDS option.

Stage C provides a ranked list of SUDS options that are appropriate for the location. Stage D provides further evaluation of the SUDS alternatives available for the site based on their site factor scores. These are further evaluated using other factors such as operation and maintenance requirements; social / ecological benefits and reliability /robustness.

Stage E addresses costs in two ways; whole life cycle costs (capital, maintenance, operation and rehabilitation), and whole life maintenance, which considers costs from the point of view of the maintaining body. When all options have been evaluated, a final decision is made.

### Case Study Example

**Overview:** The Wauchope Square redevelopment (see Figure 16) is part of the City of Edinburgh's Craigmillar Regeneration Project, which is part of an ambitious plan to transform 150-acres of open space in South East Edinburgh in Scotland into a network of new public parks, woodlands and community activity areas. This example follows the stages and processes in the SUDS for Roads Selection Flowchart.



**Figure 16. Pictures of the development at Wauchope Square**

**Stage A - Key Stakeholder and Project Description:** For this particular case study, the principal stakeholders were the residents of Craigmillar and the City of Edinburgh Council. The case study consisted of homezones or shared surfaces as the road type. From the option matrix, the applicable SUDS options were determined to be; permeable block paving, porous asphalt, the use of bioretention areas, sand filters and modular storage systems. This formed the initial list to be ranked and evaluated further.

**Stage B - Site Characteristics:** Space was at an absolute premium at the site as it is with most urban sites. The site is located close to a small stream that has been classified by the Scottish Environmental Protection Agency (SEPA) as at risk with pressures from both diffuse and point source pollution. Roads typically require two levels of treatment and the environmental risks at this site required two levels of treatment. The site was gently sloping (< 5%) and had a

total contributing drainage area of approximately 7.05 hectares. Site investigation works were carried out and groundwater depths were greater than 1m. As the project was a part of a larger regeneration project, it was deemed necessary that any proposed SUDS option should integrate seamlessly and tie in with the proposed and existing roads, utilities and other infrastructure, such as buildings, within the project.

**Applicable ranked SUDS options:** A ranked list of potential candidate SUDS was drawn up; permeable block paving; porous asphalt; bioretention areas; modular storage systems; and sand filters.

**Evaluation Stage:** In this stage, the list was narrowed down on the basis of the site factor scores. The ranked options were further evaluated based on criteria such as public health and safety concerns, aesthetics, robustness, ease of construction and maintenance etc. The options were further evaluated and screened using other factors such as social and ecological benefit, operation and maintenance requirements and other technical issues such as reliability (see Table 11).

A new school is at the centre of the new community. Consequently, any SUDS devices selected should not create the perception of public health hazards and any type of pervious pavement or bioretention must be appropriate for many children in the vicinity. Installation techniques vary for the type of permeable material chosen, but in general are similar to the requirements for the impervious materials they replace. Permeable block paving is relatively easy to construct and would therefore work well on the site. The financial driver on this project was the overall budget of £200 million for the entire regeneration project as a whole.

**Table 11. Site Risk Scoring Table**

	Permeable Block pavements	Porous Asphalt	Bioretention areas	Sand filters	Modular Storage Systems
Land / Space	1	1	1	0	1
Level of treatment	2	2	1	1	0
Contributing Drainage	1	1	1	1	1
Site Gradient	1	1	1	1	1
Water Table level	1	1	1	0	0
Underlying geology	1	1	1	0	1
Soil Type	1	1	1	1	1
Integration with existing	1	1	1	1	1
Integration With Utilities	1	1	1	0	1
Contaminated land	1	1	1	0	1
Surface Water	1	1	1	1	1
Flow attenuation	1	1	0	0	1
<b>SITE FACTOR SCORE</b>	<b>13</b>	<b>13</b>	<b>11</b>	<b>6</b>	<b>10</b>

**Final Selection:**

The stakeholders agreed to go with a final selection of permeable block paving. A guarantee was also secured from the block paving manufacturers for 15 years. The permeable block paving would combine surface stability and permeability at comparatively low cost since they are to be used where normal hard-standing such as car-parking would have to be implemented anyway.



### Removing Surface Water from Sewers

#### Purpose

The modeling software Info-Works CS was used to investigate the implications of removing surface water on a drainage network. An iterative approach was used to determine the transition steps required.

#### Impact

Removal of surface water from sewers has great potential in the reduction of energy costs of pumping surplus surface water.

#### Use and operation

Typical wastewater networks receive large amounts of surface water during rainfall. The excess flow has considerable significance on combined sewers, pumping stations and wastewater treatment works. System constraints are typically reduced carrying capacity, surcharging, and flooding incidents both external and internal. A transition in thinking is needed to retrofit systems to remove surface water and reduce operating costs. Unfortunately the works required are above ground and will frequently have major impacts on the fabric of cities.

A typical small drainage network in Scotland containing combined sewers, a pumping station and a treatment works was selected for this application. The location is at a village called Collin. The pumping station operates on a duty/standby mode and the motor rating for the pump is 9KW. The areas contributing surface water flows to the combined sewer network were identified, as were the areas that could discharge to an alternative location. In the model roads, roofs and permeable areas & driveways are all treated separately. Initially all three types of area were grouped together.

#### The tool and its developers

Info-Works CS is a commercially available package, which was used 'off the shelf' for this application.

#### Procedure used to study removal of surface water

Two different storm events were used;

Event A - 1 in 1 Year Storm Event over a 60 minute Duration

Event B - 1 in 30 Year Storm Event over a 60 minute Duration

For each event the following tasks were undertaken. For each run, the outputs were the flow rate and volume arriving at the pumping station;

- Identify the baseline flows and volumes of surface water discharging into the designated zones.
- Remove surface water flows from Zone A and re-run the model.
- Remove surface water flows from Zone B and re-run the model.
- Repeat process for the number of zones designated.

To assess the annual profile a typical year dataset was used to investigate the impact of 168 storm events over a year. In this case the outputs were flow rates and volumes pumped at the wastewater pumping station.

This allowed the financial cost using the standard £0.78 per kwh to be calculated for the various scenarios.

Note. At time of preparation, £1.00 = €1.17.

## Results

The initial modeling exercise has identified four distinct zones in the South Collin catchment. These zones (Figure 17) could have the surface water removed thereby reducing the overall flows entering the SPS and thus operational and maintenance costs.

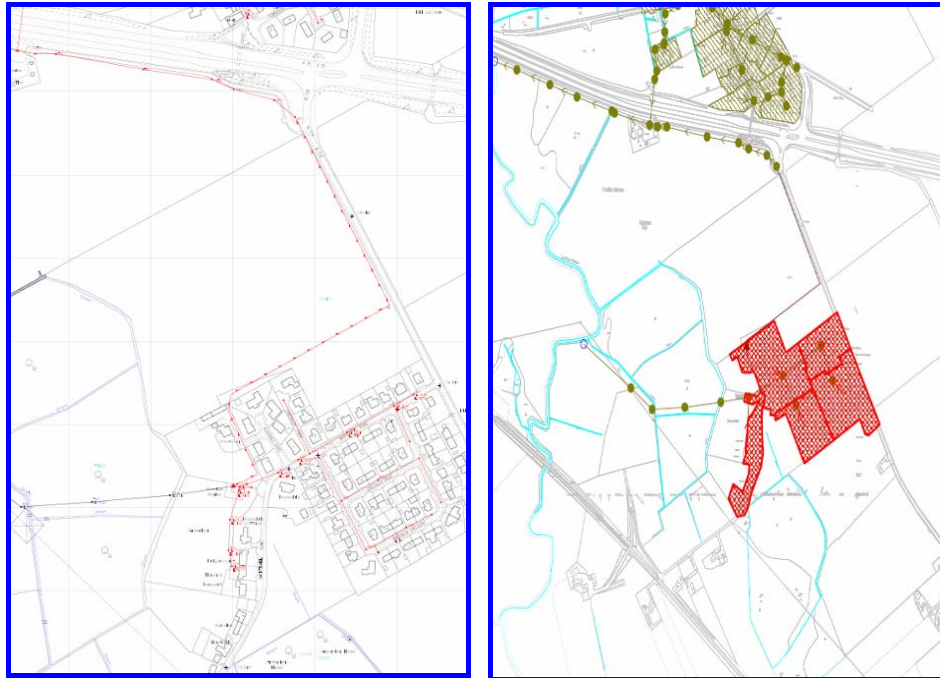

**Figure 17. Zones of Surface Water Contribution in the South Collin Catchment – South section on left and including the north section on right**

The volumes and durations of surface water removed from designated zones in Figure 17 are given in Table 12 over a one in one year 60 minute duration storm event. The financial cost of each scenario is also shown.

**Table 12. Surface Water Removal from Designated Zones in the South Collin Drainage (1 in 1 year event)**

Surface Water in Designated Zones in South Collin Drainage Catchment Area	Volume Passed Forward (m <sup>3</sup> )	Duration (h)	Power cost (£)
Baseline	140	2.6	2.03
Remove Zone A	135	2.5	1.95
Remove Zone B	108	2	1.56
Remove Zone C	117	2.17	1.69
Remove Zone D	99	1.83	1.43
Remove Zone E	126	2.33	1.82
Remove all Surface Water	23	0.43	0.34

The exercise was repeated for a 1 in 30 year event of the same duration (60 minutes) and the results are shown in Table 13.

**Table 13. Surface Water Removal from Designated Zones in the South Collin Drainage (1 in 30 year event)**

Surface Water in Designated Zones in South Collin Drainage Catchment Area	Volume Passed Forward (m <sup>3</sup> )	Duration (h)	Power cost (£)
Baseline	257	4.8	3.75
Remove Zone A	256	4.7	3.67
Remove Zone B	211	3.9	3.04
Remove Zone C	216	4	3.12
Remove Zone D	198	3.7	2.89
Remove Zone E	243	4.5	3.51
Remove all Surface Water	23	0.43	0.34

## Example 5 Removing surface water from sewers

The volumes and durations of surface water removed from the designated zones in Figure 17 over a typical year (a dataset with 168 storm events) were estimated and the results are given in Table 14. The financial expenditure for each scenario can be seen in Table 15.

**Table 14. Surface Water Removal from Designated Zones in the South Collin Drainage**

Surface Water in Designated Zones in South Collin Drainage Catchment Area	Total Volume Passed Forward (m <sup>3</sup> )	Duration (h)
Baseline	19,537	340
Remove Zone A	18,343	317
Remove Zone B	14,982	256
Remove Zone C	17,348	299
Remove Zone D	15,808	271
Remove Zone E	17,643	305
Remove all Surface Water	2,888	45

The annual power costs for 2010 and a predicted annual power cost index linked (3.5%) show the cumulative financial expenditure up to 2035.

**Table 15. Surface Water Removal from Designated Zones in the South Collin Drainage**

Surface Water in Designated Zones in South Collin Drainage Catchment Area	Annual Power Cost (£) 2010	Annual Power Cost (£) 2035	Cumulative Cost (£)
Baseline	265.20	812.75	14,141.07
Remove Zone A	247.26	804.25	13,507.27
Remove Zone B	199.68	706.26	11,826.32
Remove Zone C	233.22	775.33	13,011.26
Remove Zone D	211.38	730.37	12,239.67
Remove Zone E	237.90	784.97	13,176.59
Remove all Surface Water	35.10	80.14	1,367.14

### Discussion

Baseline Flow the flow from an area under the current situation which most likely has a high proportion of surface water inflow.

Two events were investigated: the 1 in 1 year and the 1 in 30 year storm events, each of 60 minutes duration. These two events allowed comparisons to be made. From the initial results below it is evident that there is a considerable financial benefit that could be achieved by not passing forward surface water.

#### 1 in 1 Year Storm Event, of 60 minute duration

The Baseline Flow at the pumping station was 140m<sup>3</sup>. Various scenarios were run, each reducing the contributing area and reduced to 23m<sup>3</sup> with all surface water removed. The power cost to transport the total flow during this storm event was £2.03. This reduced to £0.34 when all surface water was removed, a saving of £1.69 (83%).

#### 1 in 30 Year Storm Event, of 60 minute duration

The Baseline Flow at the pumping station was 257m. This reduced to 23m<sup>3</sup> with all surface water removed (234m<sup>3</sup> reduction or 91%). Similarly the power costs for pumping were reduced from £3.75 to £0.34 (91%).

#### Typical Year, 168 Storm Events

The third assessment concentrated upon a typical year, which identified 168 storm events over the course of a standard year. The analysis addressed only upon the storm events since, during normal operation, the pumping station only receives dry weather flow and no surface water is pumped during dry weather.

The total flow at the pumping station over the 168 storm events was 19,357m<sup>3</sup>. By removing all of the surface water the flows being passed forward by the pumping station equates to 2,888m<sup>3</sup> (reduction of 85%).

The assessment using 168 storm events for a typical year identified a significant difference between the pumped flows with and without

surface water, causing an avoidable financial expenditure. To pump baseline flow over these 168 events incurred a cost of £265.20 as opposed to a cost of pumping the dry weather flow at £35.10 (reduction of 87%). It is clear that there is a considerable difference between the energy cost for pumping the baseline flow and the dry weather flow.

### Future Vision 2035

The current profile is 2010 and the future view is 2035. When predicting the financial implications for the future vision of 2035, the figures from Table, were index linked at 3.5%. The annual power costs in 2035 for pumping the baseline flow are £812.75 and the dry weather flow £80.14.

The total energy cost of pumping the baseline flows over the 20 year period (2010 to 2035) will be £14,141.07 as opposed to pumping the dry weather flow only over the same period at £1,367.14.

### **Conclusion**

Currently Scottish Water is the single largest consumer of electricity in Scotland with an annual bill of around £40 million and is committed to identifying methods to reduce this expenditure.

By investigating the South Collin Drainage Catchment and determining the volumes and durations of the pumping station operation, it was possible to calculate the power costs and the potential financial savings that could be achieved through the removal of surface water from the network.

It is clear that there is a significant financial burden placed on the water authority to transport the surface water runoff for treatment. The future vision will have a cost of pumping the baseline flow for a total cost of £14,141.07 (€16,545.05), as opposed to pumping the dry weather flow of £1,370 (€1,599.55).

This example has focused primarily on the power requirements of the current situation and varying scenarios of removing the significant amounts of surface water entering the system. At any pumping station there are several other factors that contribute to the total cost to the drainage utility including; Chemicals, Labour, Maintenance, Spares,

Contracts, Property, Consumables, Gas, Water, Telecoms, Sludge Transport, third Party, Vehicle Costs.

While there are clear savings to be made for the drainage utility by removing the surface water, the capital costs of implementing the works required to remove the surface water may be quite significant. Very frequently short term costs outweigh the longer term benefits and no action is taken. In addition to the financial saving to be achieved at the pumping station, it is important to note that there substantial benefits throughout the network to be achieved. These include: the effect of the reduced volume requiring treatment at the wastewater treatment works; increased carrying capacity of the network allowing for future developments to be connected; reduced flooding events, whether internal or external, and potentially less pollution due to less frequent discharges to the receiving watercourse and surrounding habitat.

### WDM - Water Demand Management Options

#### Purpose

WDM is a VENSIM-based water demand management options model which provides a simple tool for urban water planners, policy makers and practitioners to compare the cost effectiveness of water demand management (WDM) options over a long term planning horizon (VENSIM 1998). The WDM Options Model is a generic decision support tool for comparing identified demand management options using the same cost metric.

#### Impact

WDM makes it easier for urban water managers, planners and policy makers to embed WDM in the strategic planning of a city.

#### Use and operation of WDM

Urban water supply and distribution has traditionally been driven by supply rather than by demand and the focus has been on major investments in the upgrading and expansion of existing water supply and distribution infrastructure. Much less attention was given to the demand-side of water supply (coming from customers). Assessing scenarios for future water demand has become part of the planning process in order to better anticipate current and future developments.

Many governments now promote a more economic use of water with, for example, subsidies on water-saving household equipment or volumetric tariffs, which increase with the level of consumption making water more expensive the more that is used. Furthermore, most water utilities have made rationalisation of water consumption key to their strategic plans.

The reasons for moving towards demand-driven urban water management are:

- Saving water
- Reducing costs
- Environmental awareness

One of the methods available to water utilities to use their water resources more effectively is through Integrated Water Resource Planning (IRP). IRP is a process of planning to meet users' needs for services in a way that satisfies multiple objectives for resource use, and recognises the fact that consumers do not demand the resource, but do generate a demand for services, i.e. demand for end uses such as washing clothes, rather than for litres of water. These end uses can be met either by increasing the supply or by using water more efficiently.

WDM addresses a wide range of factors in the IRP process (Figure 18).

#### The tool and its developers

WDM is an output of **SWITCH** work package 3.1 'Efficient Water Supply and Use'. The objective was to develop a generic demand management options model. The model was built as a decision support tool for local planners and policymakers in the urban water sector.

The tool was developed by Daniel Van Rooijen, Water, Engineering and Development Centre (WEDC), Loughborough University, UK contact Sam Kayaga at [S.M.Kayaga@lboro.ac.uk](mailto:S.M.Kayaga@lboro.ac.uk).

For more information, see Turner et. Al. (2006).

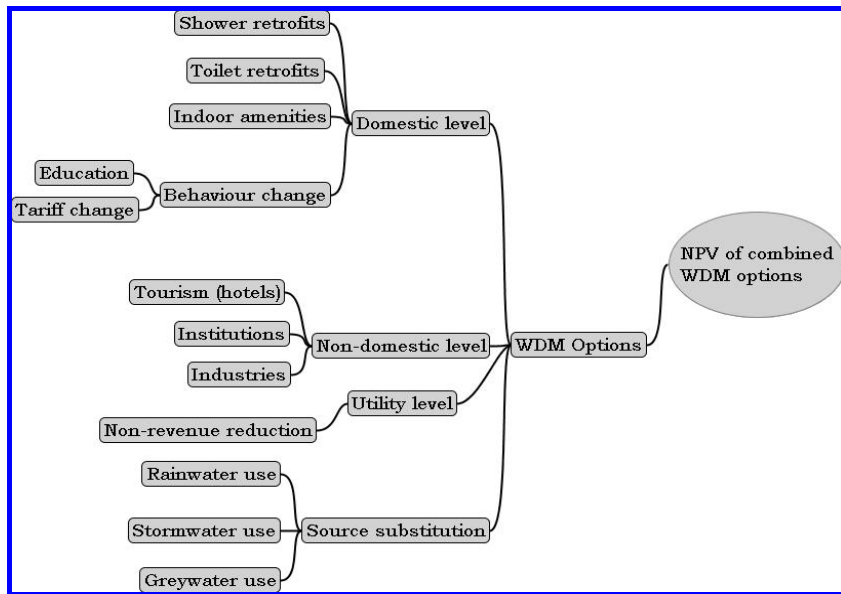

Figure 18. Factors addressed in the WDM model

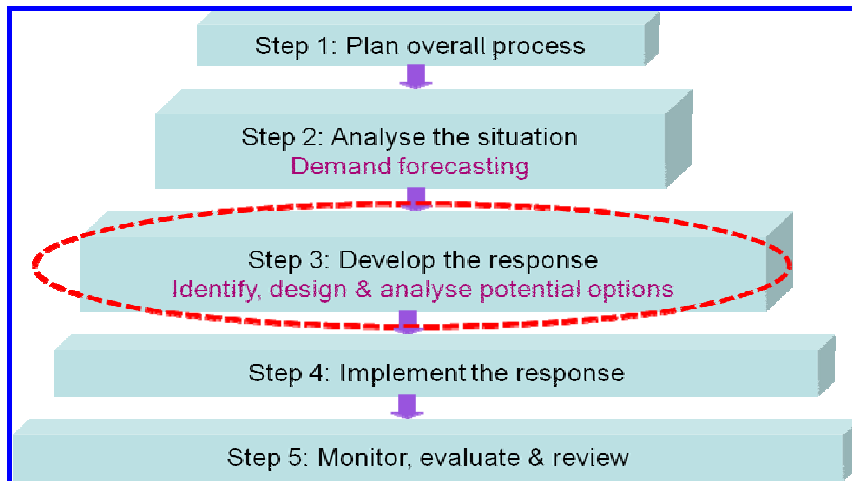

Figure 19. IRP-framework and place of the WDM model

The IRP framework consists of 5 steps in the improvement of urban water management (Figure 19). WDM is in the third step of this framework.

Water utilities in low-income countries generally use a supply-driven approach and are characterised by a relatively high fraction of non-revenue water. WDM is a tool that water utilities can use to increase the cost-effectiveness of their operations and move towards demand-driven urban water management.

### Scope of the WDM model

The model serves to show a range of possible options that can be taken in order to improve water demand management. The original model was based on an amalgamation of data from the city case studies in Alexandria and Accra and if, for example, options are to be recommended for Nairobi, then site-specific information for Nairobi would be required.

Table 16. General features of city categories

City Category	A	B
<b>General feature</b>	Low- and middle-income countries	High-income countries
<b>Level of institutional capacity</b>	Low	High
<b>Fraction of non-revenue water</b>	Low	High
<b>Rationale for WDM</b>	Financial (reducing costs)	Economic, environmental, governmental law enforcement.
<b>Water demand options likely to be most cost-effective</b>	Reducing physical losses Reducing unbilled authorized consumption Reducing water theft and metering inaccuracies	Changes in tariff Retrofits of water use equipment at households

## Example 6 Water Demand Management Options

Two categories of cities can be distinguished, each having distinct features influencing cost-effectiveness (see Table 16). Category A cities are generally located in low and middle-income countries and have a relatively low level of institutional capacity and a relatively high fraction of non-revenue water. Category B cities are generally located in high-income countries and have a relatively high level of institutional capacity and a relatively low fraction of non-revenue water. The flexible nature of the model allows for easy adjustment to city specific requirements.

### Description of the WDM Model in VENSIM

The Ventana Systems Environment (VENSIM) model was chosen for the development of WDM. VENSIM is a visual modeling tool that serves to conceptualize, document, simulate, analyse and optimise models of dynamic systems. It is simple, easy-to-use and allows for flexibility since it is user-built. The user-interface is a linked Excel input data sheet. The Excel sheet automatically opens when the model is run. The VENSIM tool has been used in a broad range of disciplines and has business, scientific, environmental, and social applications. The model is built by entering and defining causal relationships between system variables. The time frame of the model was set at 2010-2040.

### Input data

Most of the of the input data values are location specific while other values are assumed constant. In the model, some data remain constant during the modeling period while others are always variables. Model inputs consist of data for programme costs, water use (and savings) and so-called response variables. In the absence of local data, assumptions must be made on the basis of the data and information from cities in a comparable context or calculated from other data. For example, per capita water demand is often unreliable due to lack of measurements calculated from water production records and population estimates and the best estimate may be based upon a combination of local and international literature, assumptions and expert opinion.

The spreadsheet in Figure 20, requires the user to enter certain city-specific data.

WDM Options			discount rate	7%	Time step	0	1	2	3	4	5	6	7
USER INPUT	VENSIM INPUT	CALCULATED	YEAR	2010	2011	2012	2013	2014	2015	2016	2017		
general data			households	800,000									
IND USE LEVEL													
Shower Retrofits													
Participants	%	25%	1	1%	5%	10%	15%	20%	25%	25%	25%		
Water savings	threshold	3	2										
	n 30day/year	1.8	3										
	n 3year		4										
	total (m <sup>3</sup> )	10,234,600	5	14,600	73,000	146,000	219,000	232,000	365,000	365,000	365,000	365,000	365,000
	NPV m <sup>3</sup>	3,649,393	6										
Costs	total in EUR	700,000	7	200,000	200,000	100,000	100,000	100,000		0	0	0	0
	NPV EUR	520,823	8										
	NPV EUR/npv m <sup>3</sup>	0.162	9										
Toilet retrofits													
Participants	%	20%	1	1%	4%	8%	12%	16%	20%	20%	20%		
Water savings	threshold	40	2										
	n 30day/year	13	3										
	n 3year		4	93,440	467,200	934,400	1,401,600	1,688,800	2,336,000	2,336,000	2,336,000	2,336,000	2,336,000
	total (m <sup>3</sup> )	65,501,440	5										
	NPV m <sup>3</sup>	23,355,108	6										
Costs total	EUR	300,000	7	100,000	100,000	100,000		0	0	0	0	0	0
	NPV EUR	262,132	8										
	NPV EUR/npv m <sup>3</sup>	0.0112	9										
Indoor Amenities													
Participants	%	10%	1	0%	2%	4%	6%	8%	10%	10%	10%		
Water savings	threshold	23	2										

Figure 20. Model input data spreadsheet in Excel

Those cells that require user-input are marked in light blue. Cells and rows that feed into the VENSIM model are marked in pink. Cells marked in green are calculated by excel and VENSIM.

### Model structure

The model has three levels: variable, option and the options category level, as illustrated in Figure 21. The number and type of variables may differ by option but the final outputs from each option, is the same, and are expressions of 'water saved' and 'costs' of the respective option.

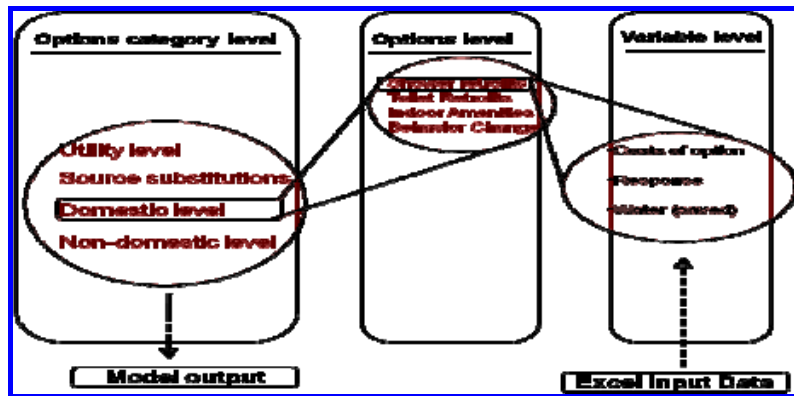

Figure 21. The three levels of the WDM model

The options level includes the 12 potential interventions that might be used to reduce urban water demand. The output of each option is expressed in costs and water saved.

### Model Output

WDM results are given in charts and tables and typical graphs are included as Figure 22 and Figure 23.

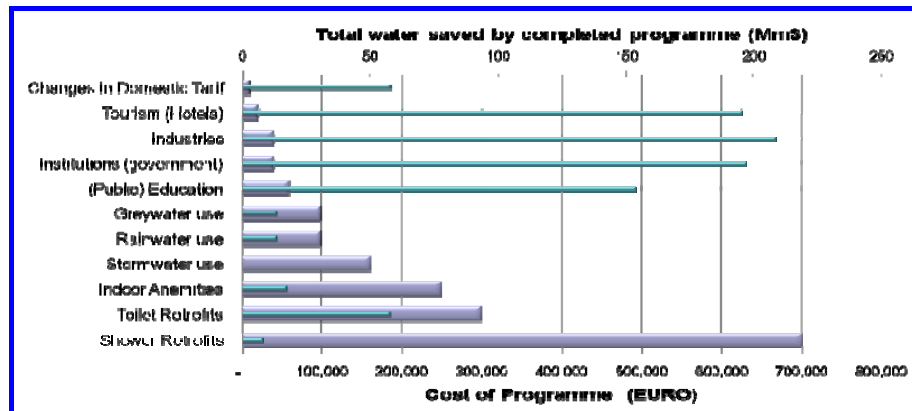

Figure 22 . Comparison of costs and water saved for the WDM options

### Cost effectiveness of programmes

Cost effectiveness (Figure 23) is an appropriate tool for judging the economic usefulness of water demand management options. It should be noted that the results only give an indication of the options unless they are based on very reliable data. The most cost effective options are: tourism, tariff change, industries, institutions and education, all costing less than €0.005 per m<sup>3</sup> (as NPV). The more moderately cost effective options (€0.01 and €0.03 per m<sup>3</sup>) are toilet retrofits, grey and rainwater use, and indoor amenities. The more expensive options are; non-revenue water, shower retrofits and storm-water use, costing over €0.1 per m<sup>3</sup> (as NPV) (Figure 23).

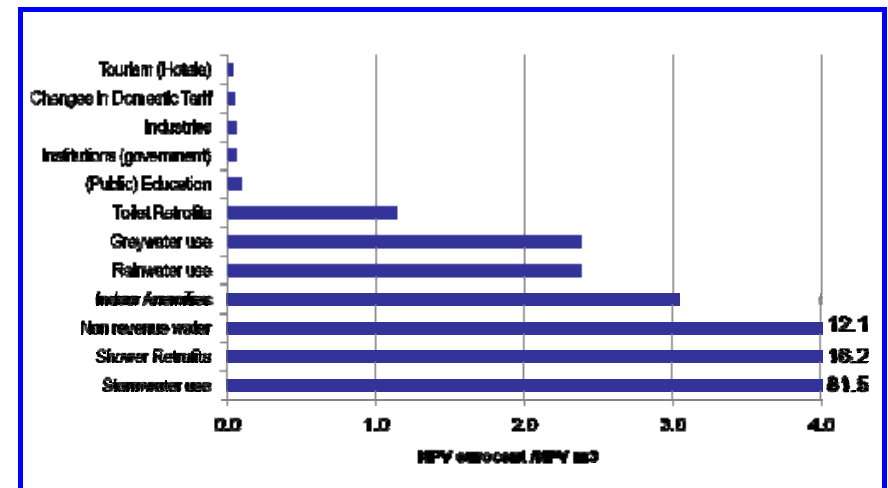

Figure 23. Cost effectiveness of WDM programmes

### Total water savings

The reduction of non-revenue water accounts for more than half of the total water that can potentially be saved. Average-size shareholders are typically industries, institutions, tourism and education (each ~7-10% of total). The remaining programmes give only marginal water saving, relative to the total, of 3% or less.



### SUDSLOC A GIS-based BMP decision support tool

#### Purpose

SUDSLOC is a GIS-based BMP tool enabling the identification of appropriate BMPs and their locations for the control of urban runoff and to reduce the pollutant loads to receiving waters. The tool identifies those sites where a selected BMP could be feasibly installed. Alternatively, sites can be examined to determine which BMPs are practicable at a location.

#### Impact

SUDSLOC supports local authority/municipal, federal/state regulatory agencies and drainage engineers in the development and evaluation of stormwater drainage infrastructure plans contained within stormwater management plans. SUDSLOC can facilitate the design, selection and location of BMP source controls to make “space for flood water”.

#### Use and operation of SUDSLOC

A number of BMP decision-support systems offer coupled GIS/hydraulic and quality modeling approaches. This “front-end” tool within a GIS-based decision-support approach is needed to provide assessment criteria to help develop, evaluate and select BMP options based on site properties, cost and other legal & social factors. SUDSLOC is capable of a more objective analysis of alternatives than has hitherto been available.

#### The tool and its developers

SUDSLOC is a **SWITCH** Deliverable from WP 2.3: Further information is available in: a GIS Data Integration Tool for Assessing Stormwater Management Options: User Guide -

[http://www.switchurbanwater.eu/outputs/pdfs/W2-3\\_DEL\\_UserGuide\\_StormwaterBMP.pdf](http://www.switchurbanwater.eu/outputs/pdfs/W2-3_DEL_UserGuide_StormwaterBMP.pdf)

Developed by Christophe Viavattene, Middlesex University, UK  
([C.Viavattene@mdx.ac.uk](mailto:C.Viavattene@mdx.ac.uk))

#### Introduction

A number of decision-support systems have been developed to assist stakeholders in the selection and implementation of appropriate stormwater control facilities. Given the range and flexibility of available options for stormwater drainage infrastructure, there is clear scope for the application of robust modeling approaches to support the selection and evaluation of viable SUDS, BMP (or other Low Impact Development; LID) options. Such approaches not only help stakeholders select appropriate BMPs, but also their strategic placement within an urban site or sub-catchment in terms of optimum performance and cost effectiveness to address concerns on environmental quality and impairment. Most approaches utilise a matrix structure based on some form of “bottom-line” criteria where BMP performance is scored against technical, environmental, economic, social, legal and/or other indicators.

To provide maximum stakeholder decision-support, these modeling tools should be seamlessly integrated within a GIS-based interface and driven by recognised hydrological, hydraulic and pollution simulation models. SUDSLOC is a placement tool for the strategic location of BMP facilities with a practical and informative assessment of those stormwater control options in terms of their water quantity and quality effectiveness. The detail incorporated in such a GIS-based approach is such that users must be expected to have at least a basic working knowledge of surface water drainage and BMP processes to appreciate and utilise their full capabilities.

#### Methodology and Model Structure

The decision support tool comprises the integration of a process-based BMP pollutant removal performance assessment with site characteristics and a multi-criteria analysis for the identification of appropriate BMPs. These components are integrated under a common ArcGIS platform with a built in Microsoft Access database

allowing the ArcGIS interface, BMP pollutant and site modules to interact and exchange data. In addition to the linkage with external hydrologic/hydraulic models such as STORM, the BMP tool includes internal, stand-alone modules that can be used individually or in combination with multi-criteria analysis (MCA), BMP pollutant process simulation or as a BMP data/information catalogue. There are three types of interactive map functionality of which the “ADD BMP Tool” option allows the user to use the mouse to add a BMP to a dedicated urban land use layer, which geo-references existing and new BMPs for further modeling analysis.

The design and structure of the major system component relationships within the BMP decision tool are shown in Figure 24. The use of discrete components developed as individual functional models in a user-friendly form gives considerable flexibility in the development and maintenance of the modeling structure. The main user GIS interface provides the flexibility to support the selection and spatial placement of BMPs and the evaluation of the sewer network from individual link up to full sub-catchment level. The MCA module allows the user to select objectives such as to minimise the total cost for a specified BMP quality effectiveness and/or set water quality control targets. The module provides a matrix-based analysis for the evaluation of a full range of criteria and indicators through a benchmarking technique.

### Model Application

SUDSLOC was site tested on the 170 ha Eastside urban development of the city of Birmingham, UK. This inner urban development area lies immediately to the south of the city centre and was undergoing major regeneration at the time of development of SUDSLOC. The area was being transformed into a new learning, technology and heritage quarter for the city and there was a common will to incorporate sustainable development into the regeneration programme. The city has major issues on both water quantity and quality, in particular, the area is subject to rising water tables resulting from a decline in the area’s industry. There are increasing sewer network surcharging problems, most of which are

related to pluvial surface water flooding. As a contribution to addressing these issues, the use of BMPs within Eastside’s ongoing and future regeneration projects was actively considered, and base data were collected to enable a preliminary application and testing of SUDSLOC.

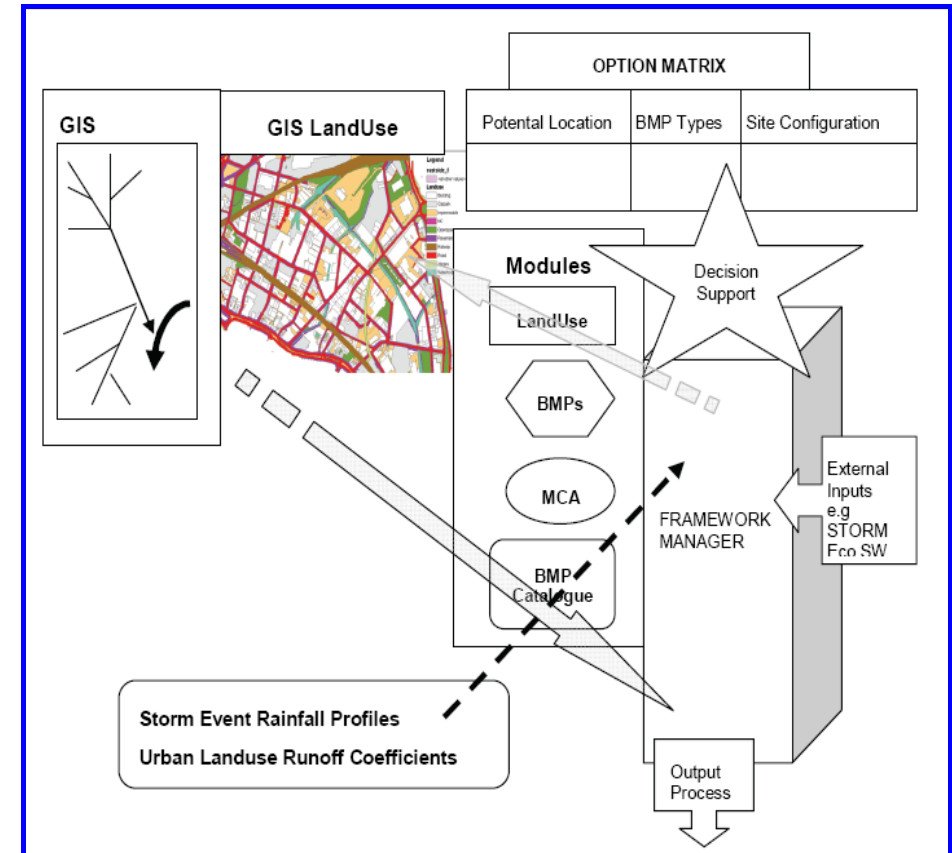
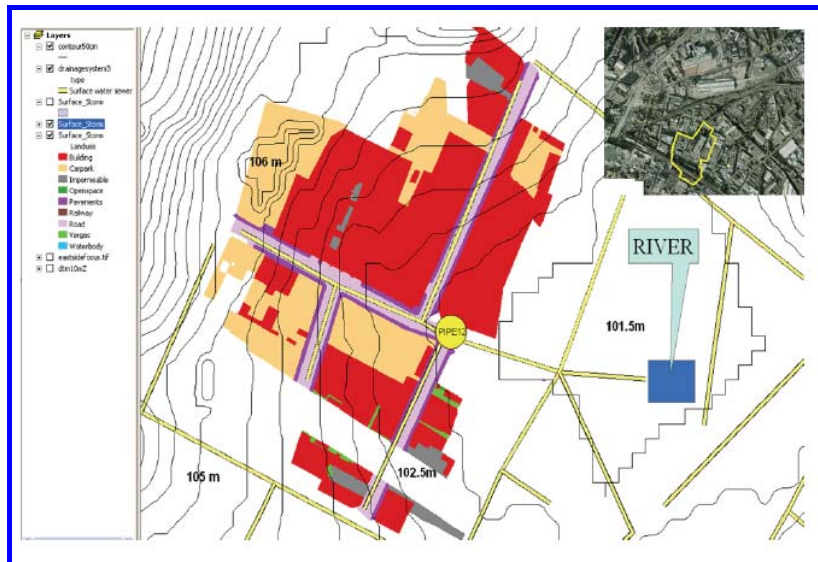

**Figure 24. Conceptual diagram of SUDSLOC**

Details of the urban land use types for a 4.5 ha section of the development site are shown in Figure 25. Further refinement to

## Example 7 SUDSLOC: A BMP decision support tool

discriminate between specific land use areas e.g. car parks, “other” impermeable hard standing areas, open spaces, derelict land and verges used images from Google Earth (2007). Soil data were obtained from the relevant geological maps and from the SOILSCAPETM Website (UK only). Surface gradients were calculated using the Digital Terrain Model (DTM) available through the national mapping service (Ordnance Survey/EDINA). Detailed groundwater data together with groundwater quality were obtained from Birmingham University. More detailed LiDAR topographic imagery enabled vertical contouring resolution of  $\pm 50$  cm. Figure 25 shows the relatively steep slopes to the north west of the development area which drain to the receiving watercourse (River Rea).



**Figure 25. LiDAR topographic image for a 4.5 ha section of Birmingham Eastside**

Consequently the flatter ground of the development area itself is subject to considerable flash flooding during extreme event conditions when the surface water outfalls to the river become blocked by rising levels in the

main channel. The proposals for extensive flat roofing, car parking and other paved surfacing within the regeneration programme offer scope for a variety of BMP options including green roofs, porous paving and small-scale bio-filtration systems, particularly for roof disconnection and road runoff.

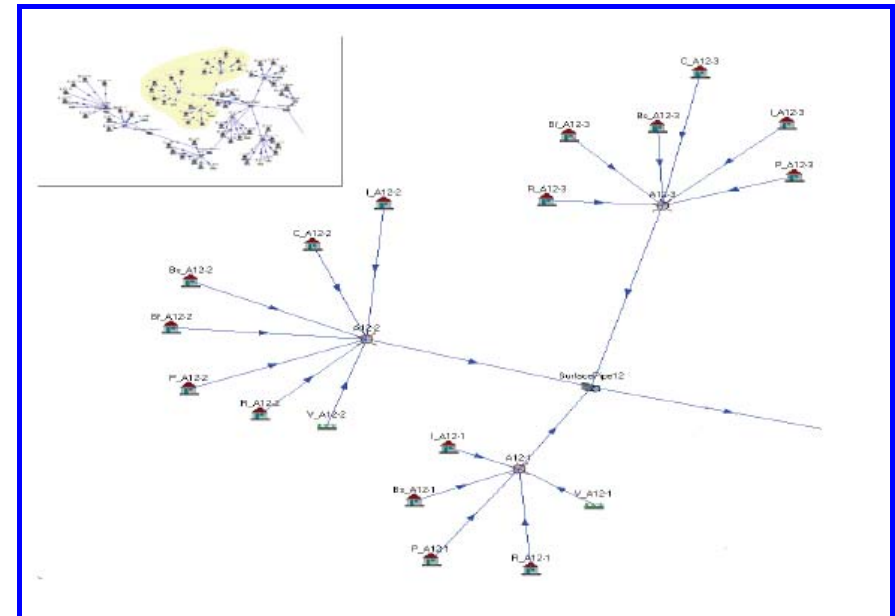

**Figure 26. The STORM modelled sewered sub-catchments in Eastside**

An extreme rainfall event (probability  $< 0.0125$ ) was used with the STORM model to derive surface water flows within the 4.5 ha section of the development area (Figure 25). There was widespread flooding from sewer surcharging, overland flow and groundwater.

For preliminary model testing it was decided to use a single design storm with a “blanket” rainfall distribution across the experimental catchment. The nodal surface water pipe (PIPE12) in Figure 26 receives the flows from three upstream sewered sub-catchments as

indicated in Figure 26 using the STORM model. These three minor branch sewers comprising the 4.5 ha experimental catchment, were used in the preliminary testing of the model and on which the preliminary results of SUDSLOC are based.

## Results and Output

SUDSLOC allows the user to identify and add a particular type of BMP to a GIS-based urban land use distribution. As the mouse cursor moves across the screen, the image changes automatically in relation to whether the site area is suitable or not for the particular BMP being considered.

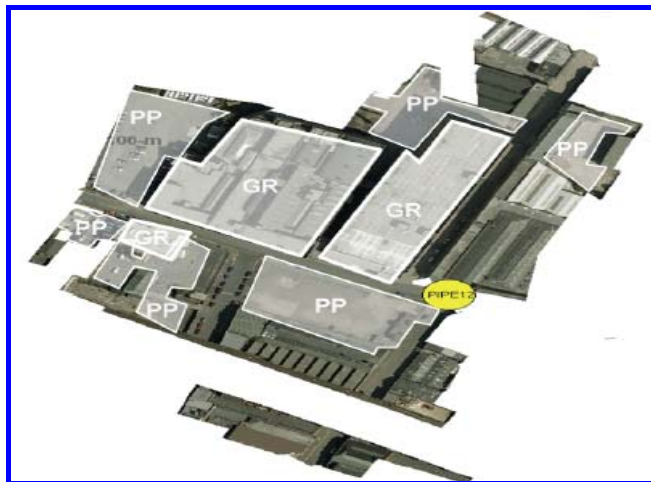

**Figure 27. Green roof (GR) and porous paving (PP) locations**

Figure 27 shows locations within the experimental subcatchment where SUDSLOC considers that both green roofs and porous paving are possible drainage solutions. Re-running the STORM model with these BMPs in place results in the simulation outcome shown in Figure 28. The reduction in the severity and incidence of surcharging is shown by the dashed line.

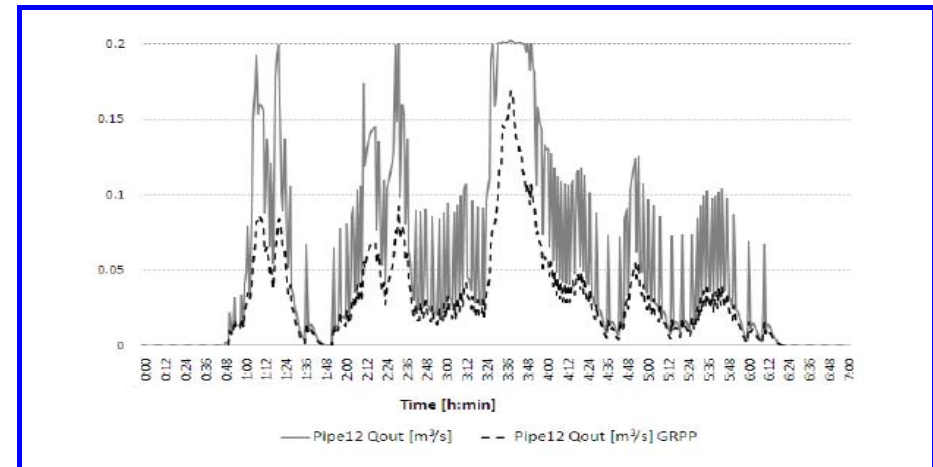

**Figure 28. Comparison between predicted flow distributions with and without BMPs installed**

The runoff reduction performance of the simulated green roof and porous paving BMPs inserted into the Birmingham Eastside development area indicate that substantial reductions in total runoff volumes can be achieved with average 22% - 28% reductions predicted by SUDSLOC for the 4.5 ha site.

## Conclusions

The results demonstrate that GIS-based platforms, such as SUDSLOC, can assist in providing a better understanding of how rainfall-urban surface-sewer interactions can lead to surface flooding. Such platforms can inform stakeholders of the benefits to be achieved by the appropriate location of selected BMPs. Where exceedance surface water flows are generated during extreme events it is important to be able to predict surface flow paths, flood depths and velocities and to achieve this, innovative coupled 1D/2D modeling approaches have been incorporated into the tool.

## Example 8 SASIW - Systematic Approach for Social Inclusion in Water Problems

### Systematic Approach for Social Inclusion (SASIW)

#### Purpose

The purpose of SASIW is to lead conflict resolution for marginalised communities where their activities impact on water bodies. The tool supports the transition of the communities and businesses towards their own sustainability.

#### Impact

SASIW is a tool that enables the social inclusion of individuals and micro companies, whose operations in the water sector are outside the formal economy. Normal laws and policies are ineffective with this group.

#### Use and operation of SASIW

The tool deals with social exclusion by improving the negotiating power of a target community without being paternalistic. The process is conducted by a change agent who is independent and needs to ascertain when to be a facilitator, a helper, or a mediator

#### The tool and its developers

SASIW was developed by Monica Sanz of the National University of Colombia, Bogota, Colombia. Please contact Monica Sanz; ([monica\\_snz@yahoo.com](mailto:monica_snz@yahoo.com))

#### Introduction

Micro and Small Enterprises (MSEs) are responsible for 70% of the industrial pollution in developing countries. However, because of their specific characteristics, existing laws and policies usually bypass them. They are part of the informal sector of economies in developing countries where, traditionally, the interests of MSEs have been put aside in favour of those of larger industries because of their lack of negotiating power. As a result, regulatory approaches for MSEs in countries such as Colombia are very unclear even though they represent 99.4% of enterprises.

Merely applying environmental laws would raise production costs and thus threaten the viability of the MSEs, potentially resulting in social unrest. However, although Cleaner Production (CP) seems to be well suited, CP programs for MSEs are not broadly implemented and end-of-pipe approaches still dominate even though they entail high costs. Thus there are frequent conflicts between MSEs and authorities.

Working with MSEs impacting upon water bodies implies designing and implementing, jointly with the target group, a strategy to resolve conflicts that is based on the need to end both the social exclusion and also technology driven end-of-pipe solutions. The strategy is based on internal strengthening of the target communities and on building strategic alliances in order to face the different issues at stake. The approach is to facilitate embedding of the prevention concepts as part of the conscious or subconscious guiding principles of operation by the owners of the industries. This enables better understanding the context and the specific needs of the MSEs. Elements of both are usually absent in mainstream consulting approaches.

The approach applies five principles to deal with the micro-tanneries from the village of Villapinzón in the Bogotá Region and is based on the theories of Negotiation, Conflict Resolution and Managed Learning. The approach uses six cyclic steps that are critically reflective and follows a systematic process aimed at raising the negotiating power of MSEs, at focusing at multilevel and multidisciplinary interventions, and at leading the marginalized communities to learn to solve their own problems. Since it supports their transition to sustainability, it also contributes to their social inclusion.

Since it is inspired by change theory, SASIW targets long-term change. It works within the cultural background of the given community and develops participatively trial and error processes instead of applying preset models for social and technical solutions.

## Use and operation

This approach allows contribution to knowledge, as well as successful change in terms of the concern of the micro-industries in developing countries. It deals with social exclusion and a mainly technical end-of-pipe focus through internal strengthening of the underprivileged community and by building strategic alliances at multiple levels and from multidisciplinary perspectives.

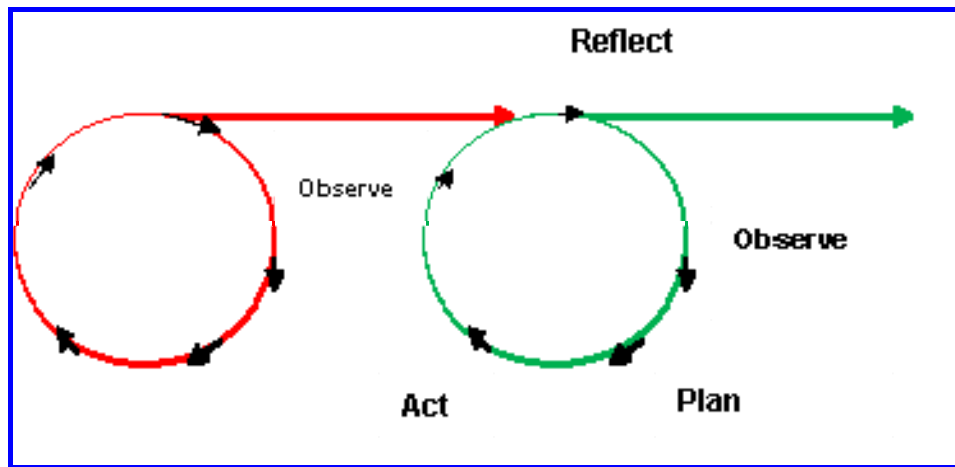

Figure 29. Cycles of action research

Since it is based on action research, it is designed on cyclic steps where one step's reflection feeds the next step's process. Each cyclic step is critically reflective and has been designed as having five elements: observe, plan, act, observe, and reflect (Figure 29). The reflection at the end of each cycle fits into the observations of the next cycle. Data collection and data analysis are developed in parallel through cyclic processes. The researcher observes and plans before acting and reflects on the findings and the methods after acting.

It works through six basic cyclic steps on a long-term action research being:

1. Preparation,
2. Building relationship,
3. Redefinition of the problem,
4. Building common grounds,
5. Agreements, and
6. Implementation and follow-up (Figure 30 and Table).

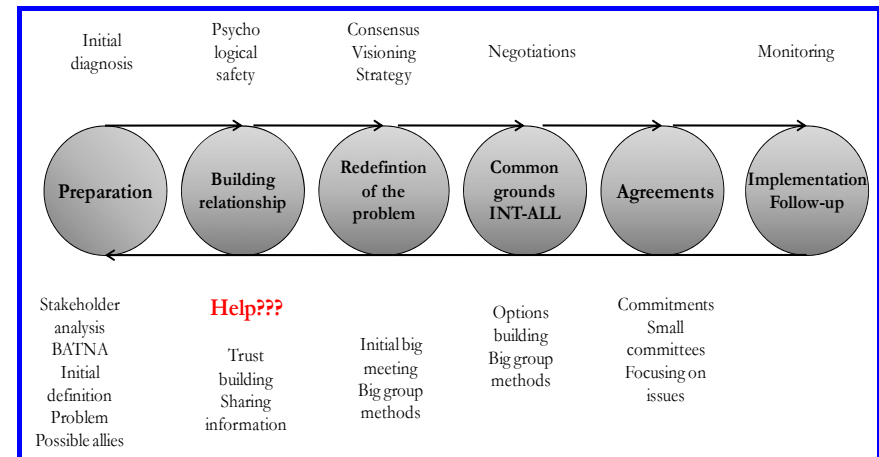

Figure 30. SASIW Systematic Social Inclusion Process

## Example 8 SASIW - Systematic Approach for Social Inclusion in Water Problems

**Table 17. Purposes of 6 step process**

	STEP	AIMING AT
1	Preparation	Initial diagnosis (identifying interests, possible allies, BATNAs (Best Alternatives to a Non Negotiation Agreement), nature of relationships, minimum intervention, indicators)
2	Building relationship	Trust- Psychological safety-Sharing information (Dialogue meetings)
3	Redefinition of the problem	Consensus- Internal Visioning- Initial building strategy
4	Common grounds INTERNALLY then AMONG ALL	Empowering communities for better win-win situations- Building realistic and accurate options- Feed-back to the strategy  (Big groups methods as Open Space Technologies)
5	Agreements	Establishing commitments- (Big groups methods)
6	Implementation Follow-up	Developing solutions by acting- Monitoring processes- Constant feed back to a dynamic process

The approach was inspired by the principles of sustainability and five principles taken from the above theories. The following principles stem from participation (1), conflict resolution (2), negotiation (3), and managed learning (action research) (4) and (5).

1. Participation - People support initiatives that they help create or, expressed differently, participation increases commitment;
2. Negotiation - When focusing on large groups as the selected targets, conflict resolution should work at building common grounds within those groups as well as at respecting individual autonomy;

3. Managed Learning - Bringing negotiation based on interests and not on positions will open up the possibility of creative outcomes that generate better results for all stakeholders involved.
4. Action Research - There is no better way to know a system than trying to change it.
5. Action Research - The learning process has better results when it works through trial and error.

This tool has implications for cities around the world that are tackling the issues of environmental pollution on river systems and of sustainability of marginalized industries.

The tool is based on a integrated theoretical and methodological framework that was inspired on the technical side on prioritizing prevention options such as Cleaner Production and on the organizational part, on the theories of Negotiation, Conflict Resolution, and Managed Learning.

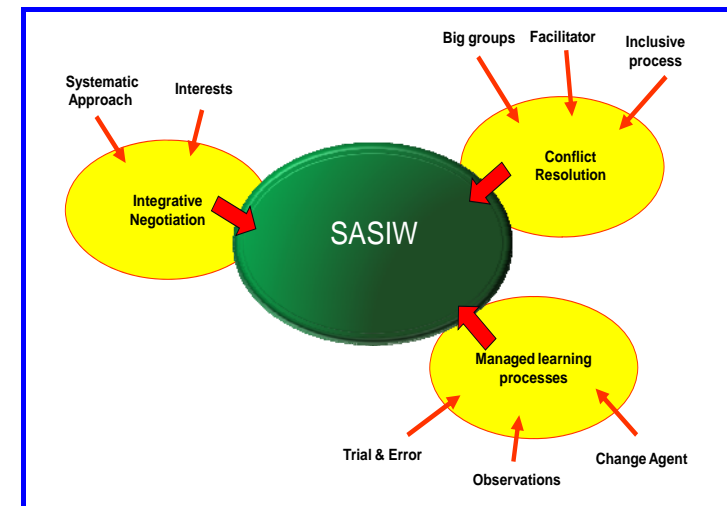

**Figure 31. Theoretical and Methodological Framework**

The theories above were used to build the tool by focusing systematic approaches, problem-solving and decision making opportunities on a given situation needing stakeholder engagement with big groups. The tool deals with social exclusion by improving the negotiating power of a target community without being paternalistic. The process is conducted by a change agent that is independent and needs to ascertain when to be a facilitator, a helper, or a mediator (Figure 31).

## Results

This approach works with big groups (a) building respect for the underprivileged' interests, (b) building consensus on a specific definition of an environmental problem, (c) building trust, (d) building commitment at long-term basis, (e) building common grounds for a technical and social approach, (f) supporting behavioural change towards prevention, (g) building innovation, (h) building environmental concern, (i) capacity building, (j) building people's dignity.

Three indicators were created to monitor the "health" of a given social system where a conflicting (or potential conflicting) situation is at the base of an initial diagnosis:

1. Having access to a high level of participation
2. Nature of the relationships among stakeholders
3. Existence of consensus regarding the causes of the problem at stake

Each of the six steps is monitored in terms of their aims (Table).

### Field Experience

The approach was developed from a specific case of tanneries in the region of Bogotá (Villapinzón). Effluent from the micro-industries had been polluting the Bogotá River for many years leading to 20 years of conflict with the regional environmental authority from the province. Six years of action research showed that:

1. through the systematic 6 step approach, the owners of the MSEs became knowledgeable regarding their own problems and willing to change. The MSEs fully supported the process which helped their own social inclusion. They incorporated the pollution prevention concepts and conflict resolution principles.
2. the tanners created a strong association of micro-tanners that participates at the regional and national committees. A positive leadership resulted among the micro-tanners and proactive attitudes dominated.
3. the tanners presented the authority with 84 environmental plans based on cleaner production that were accepted for the first time in twenty years, and grouped themselves into 7 water associations.
4. the tanners implemented cleaner production (CP) innovations into their control processes.
5. technical solutions are better worked out once the impending social challenges are faced and consensus has been built with all stakeholders.
6. recognising interdependency and long term-relationships between authorities and communities was essential to building consensus and commitments.
7. improvement of the impact of the discharges on the water quality of the Bogotá River was possible. CP implementation options, based on preliminary results from two tanneries involved in 2009 showed: 70% water savings and reductions of discharge of; 71% Chromium, 72% Sulphur, 48% BOD5, and 75% TSS compared with 2004.



### RWH - Rainwater Harvesting Tool

#### Purpose

This tool is based on a RWH demonstration in Beijing, which showed that the multifunctional use of rainwater for irrigation water supply can be financially beneficial. The tool shows how to re-design and re-build an innovative RWH system from the traditional popular designs in the region. The tool also provides details on how to monitor, record and evaluate the new methods.

#### Impact

The tool is of value to farmers in water scarce districts through building an appropriate RWH system. Production and income can increase.

#### Use and operation of RWH

The tool enables the optimisation of storage and re-use of rainwater for agriculture in a low-rainfall area. RWH tool brings a new perspective to the traditional RWH system design to make it suitable for multi-purpose use, i.e. water supply and urban agriculture. The tool also shows how the new RWH technology could be up-scaled in Beijing.

#### The tool and its developers

This tool was developed from the **SWITCH** “Water and Urban agriculture” theme. The developers were Professor Cai Jianming [caijm@igsnr.ac.cn](mailto:caijm@igsnr.ac.cn) and assistant Professor Ji Wenhua [jiwh.07b@igsnr.ac.cn](mailto:jiwh.07b@igsnr.ac.cn) of Yunnan University who was key to its development. Financial information: Meine Pieter van Dijk and Xiao Liang, UNESCO-IHE Institute for Water Education, Delft, The Netherlands.

#### Introduction

The agricultural economy worldwide is vulnerable compared with other economic sectors in urban areas. This is particularly true in China where large-scale, rapid urbanization and industrialization is causing real problems for farms which face being bought up and built on along with the

effects of pollution and waste. To make things worse, whenever a shortage of water occurs – increasingly frequently in recent years due to climate change and other reasons - urban agriculture suffers from lack of irrigation water as water resources are diverted to other sectors. This innovative tool opens the opportunity to use rainwater more effectively and economically as an additional water resource for urban agriculture.

In reality, although RWH technology is well established, the widespread use of decentralized rainwater harvesting was gradually abandoned following the development of central, large-scale water supply systems in the 20th century. Recently, more and more evidence has shown that large scale water supply systems may not be the optimal choice and may be unsustainable especially in those peri-urban areas where urban agriculture and low-end manufacturing are still the dominant economic activities. As a result, decentralized/ small scale technologies have recently received greater attention.

Due to its outstanding performance in Beijing, some local government departments and farmers have already shown interest in investing in the RWH system. Although since 2008, a range of new types of RWH have been trialed in Beijing, most have focused on two aspects: water availability and financial benefit. The benefit of RWH is not only water reuse, but also how to connect agricultural activities with RWH effectively.

#### The demo RWH

Using greenhouses for RWH has become an important way of diversifying the water supply for agricultural irrigation in water-scarce regions in China. Four basic types of greenhouse-based RWH systems are used in Beijing (Table 18). Type A, C and D save more water than type B, because they incorporate sealed storage pools and thus lose less water through evaporation. Annual evaporation in Beijing is more than three times the annual precipitation (1,842 mm

and 546 mm respectively). Thus the volume of water lost through evaporation in system type B is very high. Its water quality is also poor due to pollution and algal blooms. Consequently type B is not used extensively in Beijing.

**Table 18. Types of greenhouse RWH system in Beijing**

Type	Water from	Description of SP	Cost	Function of SP	Water quality
A	One GH	One, closed, small	High	Storing water	Good
B	Cluster	One, open, big	Low	Storing water	Poor
C	Cluster	One, closed, big	High	Storing water	Good
D	Cluster	One, closed, big	High	Storing water & crop production	Good

Note: GH – greenhouse; SP - storage pool.

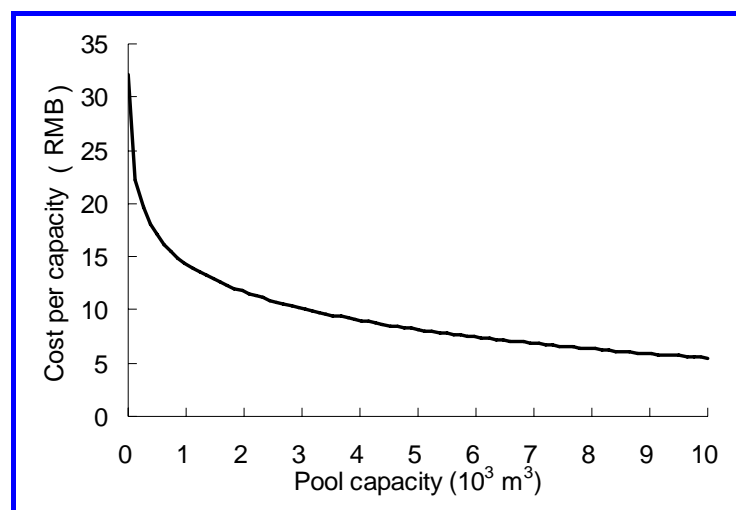

**Figure 32. Relationship between pool capacity and cost per unit of capacity**

Storage pools can benefit from economies of scale. Figure 32 describes the relationship between cost per unit and pool capacity. It shows that it is more profitable to build one larger pool than several small ones. Furthermore, it is easier to maintain and manage a large pool. This is the reason type C is considered to be better than type A.

The main challenge in implementing types A, B and C is the high cost and low economic benefit. These are key factors limiting the up-scaling of the technology. Consequently, type D, which combines water collection and agricultural production, is normally a better choice for farmers who want to use rainwater and achieve high economic returns. The high cost of the system could be reimbursed through reduced use of surface or ground water, both of which are becoming more and more costly.

The tool presents the results of an analysis of a type D RWH demonstration project. It focuses on the efficiency of water harvesting and the benefits versus the costs. It also discusses the system's potential and up-scaling mechanisms.

### Design

The greenhouse material is a plastic film (Figure 33). Filter slots totaling 500 m in length and one sediment trap (1 m<sup>3</sup>) were incorporated to remove coarse sediments and rubbish. The concrete pool was lined with impermeable material and a 60 cm layer of soil to prevent leakage.

The large storage pool collected rainwater from five greenhouses and was divided into four cisterns, each having a volume of 125 m<sup>3</sup>. The cistern connected directly to the sediment trap was a 'permanent cistern' while the other three 'back-up cisterns' were interconnected by flaps. During the rainy season, all four cisterns stored rainwater but in the dry season, only the first (permanent) cistern is used to store water and the three spare cisterns will

## Example 9 The Economics of Rainwater Harvesting

gradually dry up. The three back-up cisterns can be reused for alternative uses such as growing mushrooms or feeding animals.

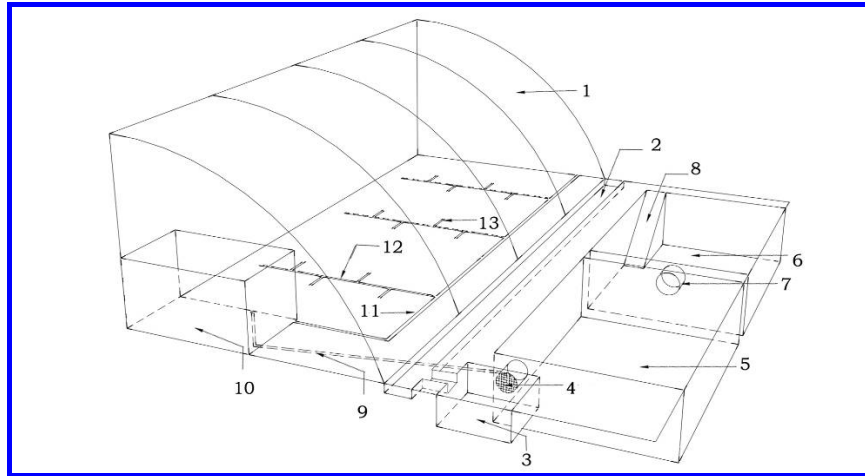

Figure 33. RWH design

### Operation and maintenance

To reuse the rainwater the system requires a pump, first to a small storage tank (most cases with 2-3 m<sup>3</sup>) in the greenhouse which further purifies the water before it can safely be used in the drip irrigation system.

Table 19. Maintaining activities needed for RWH

Items or Parts	Maintaining	Frequency	Expected service life
Surface film	Renew	Once in 2-3 years	2-3 years
Slot, trap and storage tank,	Clean	Once per year	30 years
Pump	Renew	10-15 years	10-15 years

The observations showed that this water reuse system is effective and prevents the irrigation outlets from clogging. In our demonstration case, the collected rainwater could basically meet the need for dripping irrigation. Essential maintenance activities are included in Table 19.

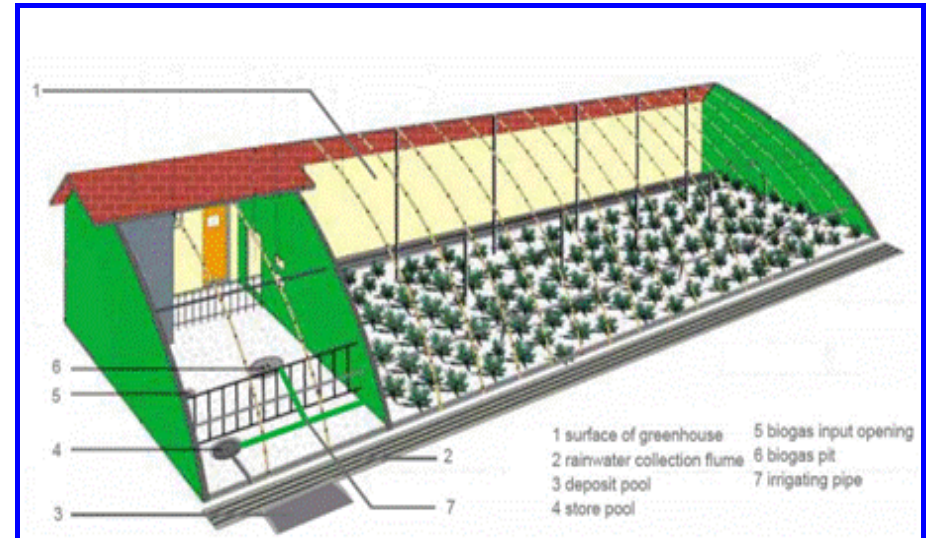

Figure 34 Illustration of RWH system in use

### Process and Results

The following performance and economic evaluation is based on two years of monitoring in 2008 and 2009.

The average annual rainfall in Huairou district, the demo site in SWITCH Beijing, was 547 mm in the period from 2004 to 2008. On average 94% of the rainfall (517 mm) occurs during April to September. The rainfall data in 2008 shown in Figure 35 shows there were 22 rainfall events between April and September, totaling 583 mm. This was 10% higher than the average from 2004 to 2008.

The highest rainfall occurred in August (151 mm) and the heaviest rainfall took place on August 10th with 56.5 mm.

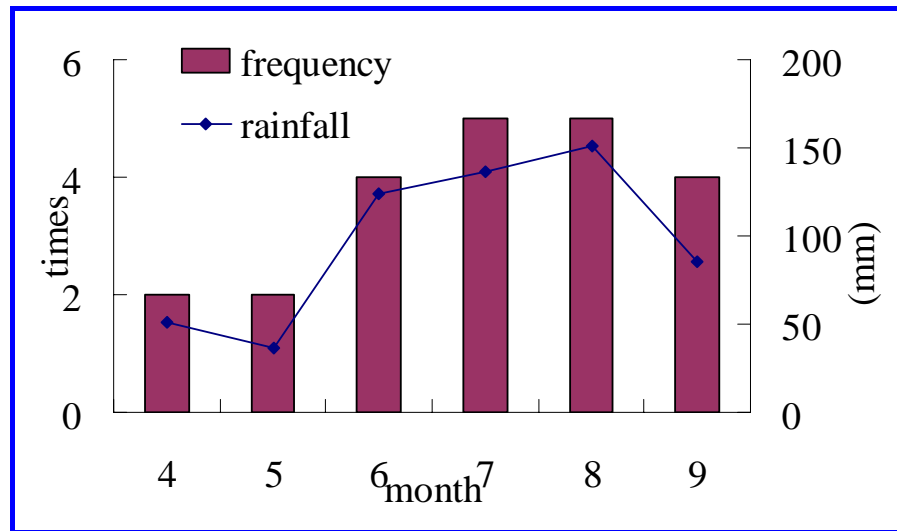

Figure 35. Rainfall at the SWITCH Beijing Demonstration site in 2008

The performance of the RWH system is shown in Table 20. RWH efficiency refers to the rate of rainwater harvested against the total rainfall on the greenhouses. Rainwater substitution refers to the proportion of rainwater used for irrigation as a percentage of total water use.

Table 20. Performance of RWH

Year	Rainwater (m3)	Harvested (m3)	RWH efficiency (%)	Substitution (%)
2008	1,865	1,233	66.1	81
2009	1,760	1,270	74.5	83

The RWH efficiency was not very high for two reasons:

1. In Beijing, the rainfall is high in summer when the average temperature is also high. Farmers have to open greenhouses to reduce the temperature and some rainwater was lost.
2. A design error was made when building the greenhouse and part of the rainwater infiltrated into the soil. Of course, these problems can be easily resolved by: a) providing timely weather information to farmers, and b) connecting the plastic sheet correctly. The rainwater harvesting efficiency could thus be improved significantly.

To analyse the costs and benefits of the RWH system, it was assumed that 70% of total fixed investment would be subsidised by the local government.

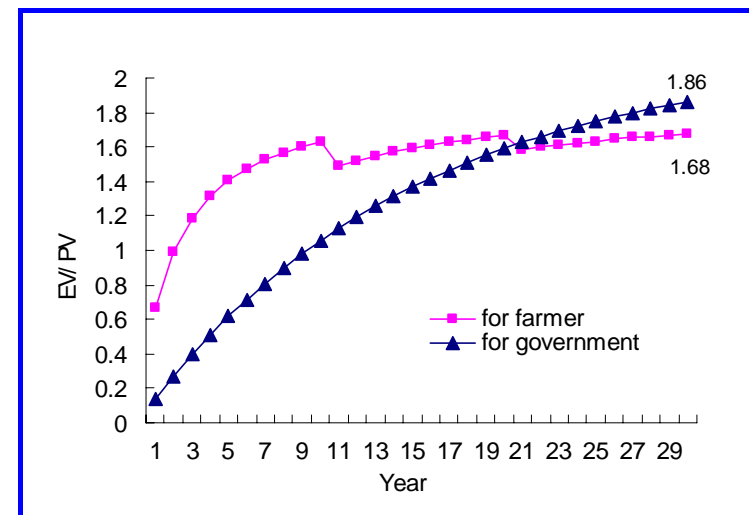

Figure 36. Benefit/cost of the RWH project

For the local government, the return on investment would be ten years (Figure 36) with a cost benefit ratio (CBR) of 1.86 giving the

## Example 9 The Economics of Rainwater Harvesting

project a high economic return. The water supply and demand balance in Beijing in future will influence the economic evaluation of the project. For example, in rainy years, the RWH system could harvest more water and the project would have a higher economic return.

The economic loss caused by the shortage of water would then decrease due to the increase in available water resources. This would decrease the economic value of the project. Further economic evaluation of the project, taking fluctuations in rainfall into account, is thus needed to better understand its potential economic impact.

The new system, which combines rainwater harvesting with agricultural production, could return farmer's investment in three years (see Figure 36). The CBR grows rapidly in the first ten years, reaching 1.63 in year ten. Additional investment is needed in the eleventh and twenty-first year for equipment renewal. Thus, the CBR of these two years decreases a little compared to the preceding years, but it is still at a high level. The CBR increases at a slower rate after the eleventh year. At most, it could reach 1.68, indicating the approach is economically feasible and able to be upscaled.

### Financial Incentives for Rainwater Harvesting

The reasons for failure to design financial incentives for transitioning to rainwater harvesting were also studied. Ten important factors including the technological and non-technological factors were chosen for the study. The results show that "doubts about the rainwater quality" and "availability of cheap groundwater" are two decisive factors determining the limited operation of the rainwater harvesting systems. If farmers have doubts about the rainwater quality or if groundwater sources are available, the rainwater harvesting systems are not in use, while if there is a shortage of groundwater sources the rainwater harvesting systems tend to operate continuously and successfully. These two decisive factors are non-technological factors but have significant effects on the operation of the

rainwater harvesting systems. Many farmers consider that rainwater in Beijing is not suitable for irrigation.

However, at the moment there is no systematic information proving whether rainwater in Beijing is suitable or not, hence other solutions need to be sought.

### Possible solutions

Given the non-technical nature of the problem, three possible solutions were explored:

- Increase the subsidies on investment and maintenance of rainwater harvesting systems.
- Tax the use of ground water
- Increase the price of municipal piped water

### Increase the subsidies on investments and maintenance of rainwater harvesting systems

Subsidies for initial investment can effectively help to lessen the farmers' expenditures. For larger systems initial investments are higher. For example, for the small size of rainwater harvesting systems with the capacity of 50 m<sup>3</sup>, the initial investment is around 27,000 Yuan (or 2700 US dollar) including the construction and equipment. The capacity of 50m<sup>3</sup> is only suitable for supplementing the needs of a household. The total average income of a small household of farming in Beijing is around 10,000 Yuan per year, meaning the initial investment is almost three times their income. If there are no subsidies, it is very difficult for farmers to afford such an initial investment. Hence most rainwater harvesting systems are provided with subsidies of around 50 to 100 percent of the initial investment although some systems are subsidized by less than 50% of initial investment.

Some state-owned facilities receive already subsidies for the expenses related to the operation and maintenance of the rainwater harvesting equipment. However, similar subsidies are not available for private operators. Government subsidies may be a beginning, but are not sufficient to promote rainwater harvesting in Beijing, in a sustainable way. The confidence in rain water also needs to increase to get successful rainwater harvesting systems in Beijing. Increasing the barriers to obtaining groundwater is another important step.

All kinds of measures such as pricing ground water, prohibiting building new wells, and limiting the quantity of ground water pumping may be required.

### **A tax on ground water**

It is often convenient for the farmers to access groundwater. Pumping it up is cheap and no tax or regulation withholds them. This means there is a need for clear financial incentives to change their behavior. As the cost of using groundwater is too low, farmers have few incentives to use rainwater. In order to motivate the consumption of rainwater, the Beijing Water Authority is expected to raise the cost of using groundwater through collecting a charge for groundwater. While higher cost of groundwater can effectively increase the consumption of rainwater, it can have a negative impact on farmers' incomes. The challenge is to increase rainwater consumption by charging for groundwater while not discouraging farming. We found that the optimal ground water charge may not be high enough to discourage the use of ground water all together. For that reason other policies are necessary as well, in particular more strict regulation.

### **An increase of the price of municipal piped water**

The price for reclaimed water is 1 Yuan/m<sup>3</sup> in Beijing while the price of drinking water is 3.7 Yuan/m<sup>3</sup>. The rate of 1 Yuan/m<sup>3</sup> for reused water does not reflect the real cost. Therefore, rain water harvesting systems cannot be financially feasible as long as these cheap alternatives are available.

### **Transitioning to the solution**

China is convinced it has to make better use of scarce resources such as ground water, because per capita water consumption is more than water availability and the population of the Chinese capital keeps growing. Given the urgency, a choice will have to be made to either impose stricter regulation for ground water use, or to discourage its use by imposing a ground water tax. However, the low current rate charged for treated and reused water is a crucial factor why these systems are not financially feasible. The reused water rate is lower than the actual O&M cost of rainwater systems and hence needs to be increased. Transitioning should take a three pronged approach. After finding the optimal level of subsidies, a tax on ground water needs to be introduced, which does not discourage farming. It will be necessary to also impose more strict regulations on the use of ground water and then finally only in combination with an increase of the price of drinking and reused water we can expect the desired effect, a larger uptake of rainwater harvesting systems.

### Costing for sustainable outcomes

The cost of undertaking actions for change is one of the most critical criteria in the evaluation of success or failure. Since few of the SWITCH demonstrations explicitly included implementation costings, a number of costing methodologies from the literature are included in this section.

### Sustainable Outcomes - a Guidebook

In the guidebook 'Costing for Sustainable Outcomes Urban Water Systems', Mitchell et. Al. (2007) provide an overview of the need for new costing approaches to address the challenges of transitioning to sustainable urban water systems. This is because the new systems encompass new technologies, new outputs and services, new management approaches, new risks, new business models, new regulatory arrangements and new operating and institutional arrangements. Costing of the new systems is a key issue for decision makers involved with urban water infrastructure. Least-cost studies will inform investment decisions for promoting sustainable outcomes. Core Meeting sustainability means ensuring that solutions that meet environmental objectives are adopted without incurring high costs.

Mitchell et al (IBID) advocate cost effectiveness analysis over cost benefit analysis as this compares alternative ways of meeting the same objective. Further, when costing for sustainable outcomes, this method has the advantage of being used to identify the least-cost means of providing specified water services. Life cycle costing is also a form of cost effectiveness analysis as it is more responsive to costs that accrue over the whole life cycle of the asset including capital expenditure, installation, operation, maintenance, refurbishment, decommissioning and disposal costs. Life cycle costing is important for sustainable urban water outcomes because the distribution of costs across these life cycle elements can vary markedly between options and have significant financial impacts.

### Costing Principles

- Use appropriate cost perspectives
- Provide water service outcomes
- Think in terms of systems
- Include life cycle costs
- Assess on the basis of incremental costs
- Account for externalities
- Account for the time value for money
- Acknowledge and manage precision and uncertainty
- Report transparently

### Durban (South Africa) - financing implementation of new technologies

Access to clean water and sanitation is a basic human right. However, water services need not necessarily be free of charge as is currently the case in many cities in developing countries, which are trying to improve services to their citizens. Ethekewini Water and Sanitation is a good example of an innovative method of costing of water services and moves away from established attitudes to urban water management. In Durban, as in many cities throughout the world, there is a backlog of infrastructure neglect that has left the poorest area without basic services. Ethekewini supplies 900ML of water per day through 400,000 service connections. The company's pro-poor policy is to supply 200 litres/day for each family at no cost. Each household is supplied with a 200 litre polythene tank that is filled each night with any additional supply being metered and charged on a rising block tariff. As a result, the basic amount of drinking water is supplied while minimising wastage.

## The OECD 'Managing Water for All' report (2009)

The OECD report 'Managing Water for All' (2009) states that poor governance and inadequate investment are resulting in billions of people not having access to water and sanitation services due to the deterioration and eventual collapse of infrastructure. The report focuses on the '3Ts' for investment in the water sector. The 3Ts are:

1. Taxes,
2. Tariffs,
3. Transfers.

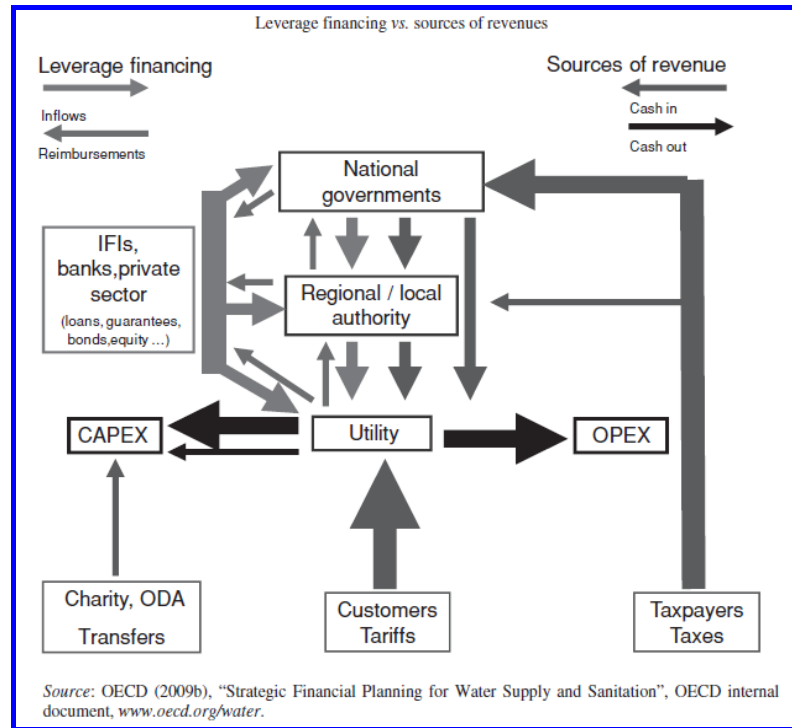

Figure 37 Financial flows to water supply and sanitation

OECD also stresses the importance of strategic financial planning to find the right 3Ts mix for achieving water and sanitation targets and for leveraging other sources of finance. The report also adds that tariffs play a vital role in achieving sustainable cost recovery while ensuring affordability.

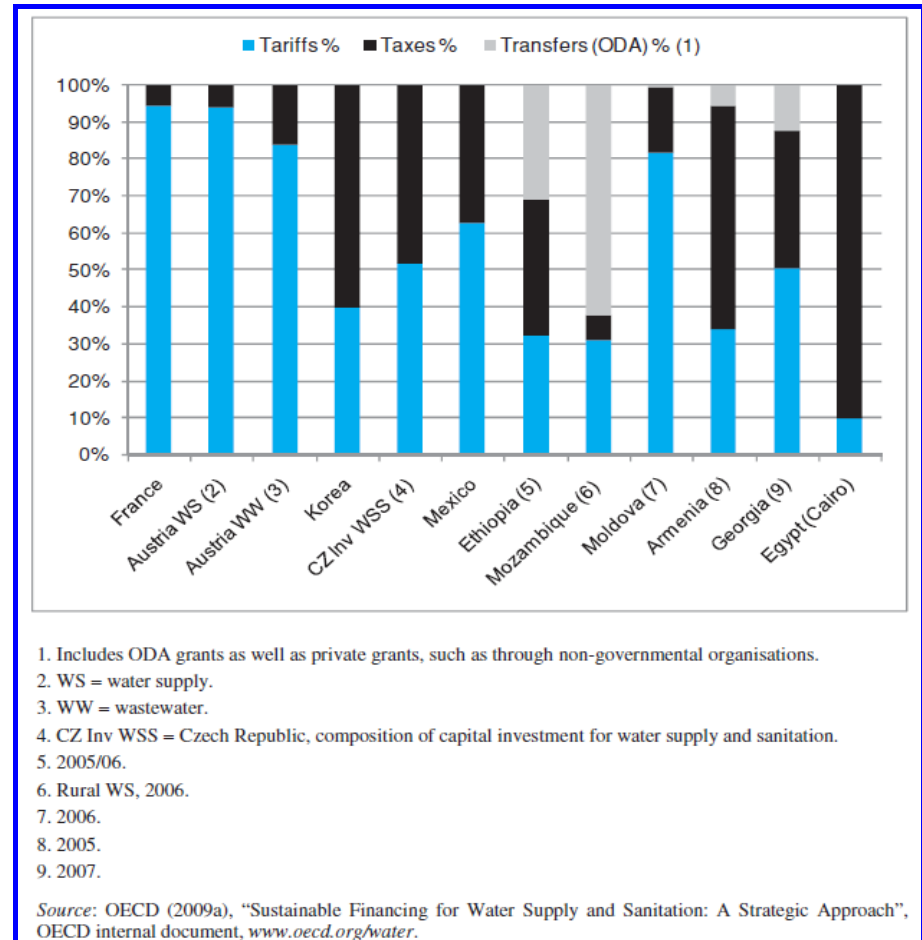

Figure 38. The share of the '3Ts' between countries



## Example 10 Costing for Sustainable Outcomes

The 3Ts represent those who actually pay for water and the revenues gained by this strategy as opposed to full cost recovery by tariffs only. The 3Ts contribute to the principle of sustainable cost recovery, which is the more realistic and practical policy.

Figure 38 shows the differences between the '3Ts' in different countries for water supply and sanitation finance. There is no 'one size fits all' model to financing. At one extreme are poor countries that rely heavily on transfers such as those received from development assistance programmes. At the other extreme, developed countries raise nearly all their revenue through tariffs and taxes. The most appropriate combination will depend on policy objectives and the local context.

### Rehabilitation of water supply and sanitation in OECD countries

Significant investment is required in most OECD countries to rehabilitate existing infrastructure to maintain service quality and conform with environmental and health regulations. Figure 39 shows the investments required in OECD and emerging economies (Brazil, Russian Federation, India, China).

Analysis of this information shows that France and the UK will need to increase water spending as a share of GDP by as much as 20% to maintain water services at current levels. Furthermore, Japan and Korea will need to increase water spending by more than 40%.

	GDP (USD billion)	GDP/cap (USD)	GDP growth %	Current expenditure on water infrastructure (USD billion)	Projected expenditure on water infrastructure as % of GDP		Average annual investment (USD billion)	
					By 2015	By 2025	By 2015	By 2025
Australia	602	29 893	2.3	4.515	0.75	1.08	6.86	9.95
Austria	254	31 254	2.3	1.905	0.75	0.89	2.59	3.91
Belgium	309	29 707	2.3	2.318	0.75	0.69	2.75	4.38
Canada	1 050	32 921	2.3	7.875	0.75	0.83	10.27	15.74
Czech Republic	187	18 370	2.3	3.553	1.90	0.85	3.12	2.83
Denmark	178	3 389	2.3	1.335	0.75	0.89	1.82	2.74
Finland	152	29 305	2.3	1.140	0.75	0.69	1.35	2.15
France	1 724	27 738	2.3	12.930	0.75	0.83	16.86	25.84
Germany	2 391	28 988	2.3	17.932	0.75	0.83	23.38	35.84
Greece	224	20 362	2.3	1.680	0.75	0.81	2.17	3.34
Hungary	152	15 546	2.3	1.140	0.75	1.37	2.02	2.79
Iceland	10	33 269	2.3	0.075	0.75	0.69	0.09	0.14
Ireland	152	37 663	2.3	1.140	0.75	0.69	1.35	2.15
Italy	1 620	27 984	2.3	12.150	0.75	0.92	16.83	25.23
Japan	3 817	29 906	1.9	28.627	0.75	1.26	46.98	63.41
Korea	1 030	21 419	2.3	7.725	0.75	1.23	12.76	18.00
Luxembourg	28	63 609	2.3	0.210	0.75	0.64	0.24	0.39
Mexico	1 006	9 887	2.4	19.011	1.90	0.85	16.78	15.36
Netherlands	477	29 332	2.3	3.577	0.75	1.08	5.43	7.88
New Zealand	97	23 943	2.3	0.727	0.75	1.13	1.14	1.63
Norway	184	405	2.3	1.380	0.75	0.64	1.58	2.55
Poland	475	12 452	2.3	9.025	1.90	0.85	7.93	7.18
Portugal	194	18 503	2.3	1.455	0.75	0.88	1.96	2.97
Slovak Republic	81	1 566	2.3	1.539	1.90	0.85	1.35	1.22
Spain	971	23 627	2.3	7.282	0.75	1.06	10.97	15.96
Sweden	254	28 205	2.3	1.905	0.75	0.69	2.26	3.60
Switzerland	230	31 690	2.3	1.725	0.75	0.64	1.97	3.19
Turkey	530	7 503	3.5	10.07	1.90	0.85	9.33	9.66
United Kingdom	1 736	28 938	2.3	12.499	0.72	0.86	19.14	27.96
United States	11 724	39 496	2.5	87.930	0.75	0.64	101.65	167.63
Brazil	1 462	849	2.4	2.924	0.2	1.9	19.8	32.02
Russian Federation	1 449	10 179	3.5	4.637	0.32	0.85	11.49	26.41
India	3 291	380	4.1	23.366	0.71	2.5	74.8	108.31
China	7 334	5 642	5.3	110.01	1.5	1.9	182.1	247.18
Total				405			6 212	9 003

Source: OECD (2006), *Infrastructure to 2030: Telecom, Land, Transport, Water and Electricity*, OECD, Paris, p. 313.

Figure 39. Projected expenditure on water and wastewater services

The other option to rehabilitation is to 'run to failure', the concept in asset management where it is efficient to stop repairing the old systems and eventually replace it with new generation systems or leapfrog both strategies altogether by opting for implementing new generation systems where feasible.



## *Section 7*

*Further Information*

## References

- Batchelor C., and Butterworth J. (2008) SWITCH Learning Alliance Briefing Note 9: Visioning. At <http://www.switchurbanwater.eu/outputs>
- Beddow V. Cities of the Future. Article in WaterWiki at <http://www.iwaterwiki.org/xwiki/bin/view/Articles/CitiesoftheFuture#Attachments> Accessed 29/3/2011.
- Brown, R., Keath, N., Wong, T., (2008). *Transitioning to Water Sensitive Cities: Historical, Current and Future Transition States*. Proc 11ICUD, EICC, Edinburgh, Scotland. 31 August - 5th Sept. ISBN 978 1899796 212.
- Butterworth, J., Dasilva, C., (2007). SWITCH Learning Alliance Briefing Note 7: A framework for monitoring and evaluation of project outcomes.** Article 13 CSR Expert View : Leapfrogging: a different route to development at :  
[http://www.article13.com/A13\\_ContentList.asp?strAction=GetPublication&PNID=1192](http://www.article13.com/A13_ContentList.asp?strAction=GetPublication&PNID=1192)
- Daigger, G. (2009) Evolving urban water and residuals management paradigms: Water reclamation and reuse, decentralization, resource recovery, *Water Environment Research* 81(8):809-823
- Geels, F., Kemp, R., (2000). Transitions from a societal perspective. UNU-MERIT Maastricht, The Netherlands.
- Grin, J., Rotmans J., and Schot, J., in collaboration with Geels, F., Loorbach, D. (2010). *Transitions to Sustainable Development New Directions in the Study of Long Term Transformative Change*. KSI. Routledge. ISBN: 978-0-415-87675-9
- Ison, R., Collins, K., Bos, A., Iqinto, B., (2009). *Transitioning to Water Sensitive Cities A summary of the key findings, issues and actions arising from five national capacity building and leadership workshops*. International Water Centre. [www.watercentre.org](http://www.watercentre.org)
- Loorbach, D.A., (2007). *Transition Management: New mode of Governance for sustainable development*. PhD, Erasmus University, Rotterdam. ISBN: 978 90 5727 0574
- Loorbach, D., Rotmans, J., (2006). 'Managing Transitions for Sustainable Development', Chapter X. Olshoorn, Wieczorek, A.J. (ed) *Understanding Industrial Transformation. Views from different disciplines*, Dordrecht: Springer.
- Mitchell, C.A., Fane, S.A., Willetts, J.R., Plant, R.A. & Kazaglis, A. 2007, *Costing for sustainable outcomes in urban water systems - a guidebook*, [Cooperative Research Centre for Water Quality and Treatment], Institute for Sustainable Futures, UTS/The Cooperative Research Centre for Water Quality & Treatment, Sydney, pp. 1-86.
- Moriarty P. (2007) SWITCH Learning Alliance Briefing Note No.4: A brief introduction to action research concepts and practice. At [http://www.switchurbanwater.eu/outputs/pdfs/WP6-2\\_BRN\\_4\\_Action\\_research.pdf](http://www.switchurbanwater.eu/outputs/pdfs/WP6-2_BRN_4_Action_research.pdf)
- Nelson, V.I., (2008). Viewpoint: *Truly Sustainable Water Infrastructure It's time to invest in next-generation decentralised technologies*. WE&T Magazine Water Environment Federation, September, Vol 20, No. 9.
- Novotny V and Beddow (V) (2010) Cities of the Future discussion in Wicki Water.  
<http://www.iwaterwiki.org/xwiki/bin/view/Articles/CitiesoftheFuture>
- Novotny, V. and P. Brown (2007) *Cities of the Future-Towards Integrated Sustainable Water, Landscape and Infrastructure Management*" IWA Publishing Co., London
- Organisation for Economic Cooperation and Development (2005) *Managing Water for All – an OECD Perspective on Pricing and Financing*. Prepared for World Water Summit Istanbul March 2005.
- Rotmans J., Van Asselt M., Anastasi C., Greeuw S., Mellors. J., Peters. S., Rothman, D., Rijkens, N. (2000). *Visions for a*

## References

*sustainable Europe. Futures*, Volume 32, Issues 9-10, November 2000, Pages 809-831. doi:10.1016/S0016-3287(00)00033-1.

Shouten T. (2007) SWITCH Learning Alliance Briefing Note No.6: Process Documentation. At [http://www.switchurbanwater.eu/outputs/pdfs/WP6-2\\_BRN\\_6\\_Process\\_documentation.pdf](http://www.switchurbanwater.eu/outputs/pdfs/WP6-2_BRN_6_Process_documentation.pdf).

Da Silva C. (2007) SWITCH Learning Alliance Briefing Note No.3: A review of our own thinking on learning alliances. [http://www.switchurbanwater.eu/outputs/pdfs/WP6-2\\_BRN\\_3\\_LA\\_thinking\\_revisited.pdf](http://www.switchurbanwater.eu/outputs/pdfs/WP6-2_BRN_3_LA_thinking_revisited.pdf)

Smith. A and Stirling. A., (2008a). *Shaping technology systems: critical issues for sustainability governance. Long-term policies: governing socio-ecological change, Panel on Shaping System Dynamics*. UKIHDP Conference, Berlin.

Smith. A and Stirling. A., (2008b). *Socio-ecological resilience and socio-technical transitions for sustainability governance. STEPS Working Paper 8*, Brighton: STEPS Centre.

Van der Steen P. and Howe C. (2009) Managing Water in the City of the Future; Strategic Planning and Science. *Reviews in Environmental Science and Bio-Technology*, Vol. 8, No. 2, p 115-120

Tellam J., Mackay R., Riley M., Renshaw J, M.Rivett, Greswell R., Aller F. and Durand V. (2007) *Are Viruses a Hazard in Waste Water Recharge of Urban Sandstone Aquifers?*  
<http://switchurbanwater.lboro.ac.uk/outputs/pdfs/>

Turner, A., Willets, J., Fane, S., Guirco, D., Kazaglis, A., and White, S. (2006) *Planning our future urban water resources: A guide to demand management in the context of integrated resource planning*, Institute of Sustainable Futures, University of Technology, Sydney.

VENSIM (1998) *The Ventana Simulation Environment, VENSIM PLE Plus Version 5.3a*. Copyright 1988-2003 Ventana Systems, Inc.

Verhagen J (2007) Learning Alliance Briefing Note 2: Stakeholder Analysis at [http://www.switchurbanwater.eu/outputs/pdfs/WP6-2\\_BRN\\_2\\_Stakeholder\\_analysis.pdf](http://www.switchurbanwater.eu/outputs/pdfs/WP6-2_BRN_2_Stakeholder_analysis.pdf)

Van Dijk, M.P., Liang, Xiao (2009). *Water governance in the water and sanitation sector in Beijing, the capital of China*. Meeting on water governance in SWITCH cities, Delft, February Unpublished.

## Web Links

**KSI** is the Dutch Knowledge network on System Innovations where many researchers are working together to understand, identify and influence the process of transitions to a sustainable society.

<http://www.ksinetwork.nl>

**The National Urban Water Governance Programme.** Monash University. This is a social research programme aimed at facilitating progress towards water sensitive cities in Australia.

<http://www.urbanwatergovernance.com/publications.html>

**Science at the Shine Dome.** An annual 3 day event held by the Australian Academy of Science. In 2002 the public symposium covered the environmental, economic and social aspects of sustainability.

<http://www.science.org.au/events/sats/sats2002/symposium.htm>

**NeWater.** studied and fostered Adaptive Integrated Water Resources Management as a concept guiding theory and practice. A guiding principle in NeWater was co-developing and co-applying knowledge and tools with stakeholders and scientists.

<http://www.newater.info/>

**INECO.** The aim of INECO is to establish a Mediterranean network of research institutes, public authorities and stakeholders for coordinating research, and to analyse decision making practices regarding the application of institutional instruments in the water sector.

<http://environ.chemeng.ntua.gr/ineco/Default.aspx?t=10>

**Urban Water.** The vision of Urban Water was to develop a holistic and generally systemic approach for sustainable water management in urban areas. The partners worked together on solutions to integrate spatial planning and water management.

<http://www.urban-water.org/cms/>

**AQUASTRESS.** A project delivering interdisciplinary methodologies enabling actors at different levels of involvement and at different stages of the planning process to mitigate water stress problems. The project draws on both academic and practitioner skills to generate knowledge in technological, operational management, policy, socio-economic, and environmental domains.

<http://www.aquastress.net/>

**MATISSE** aimed to achieve a step-wise advance in the science and application of Integrated Sustainability Assessment (ISA) of EU policies. The core activity of the project was to improve the tools available for conducting Integrated Sustainability Assessments.

<http://www.matisse-project.net/projectcomm/>

**Hammarby Sjöstad** is a suburb of Stockholm which claims to be one of the highest profile examples of sustainable city development. Detailed and integrated schemes have been developed for energy, water & sewage and waste & recycling and the 'Hammarby Sjöstad model has been developed.

<http://www.jetsongreen.com/2007/10/hammarby-sjostad.html>





For more information  
visit:  
[www.switchurbanwater.eu](http://www.switchurbanwater.eu)



or contact:  
Urban Water Technology Centre  
University of Abertay



Bell Street  
Dundee  
DD1 1HG

United Kingdom

Tel: +44 (0) 1382 308170

Email: [UWTC@Abertay.ac.uk](mailto:UWTC@Abertay.ac.uk)

Web: [www.uwtc.tay.ac.uk](http://www.uwtc.tay.ac.uk)



The aim of the SWITCH project was to achieve more sustainable urban water management in the “City of the Future”. A consortium of 33 partner organizations from 15 countries worked on innovative scientific, technological and socio-economic solutions, which could be more speedily replicated around the world.

